

GOLD FLUSH-FIT

IP40 FLUSH-FIT DISTRIBUTION BOXES HOLLOW WALLS

Description: IP40 FLUSH-FIT BOX 2x12 (24) MOD. PE+N

Reference:

GPE24PT/PH/RR

Characteristics:

Product type:	IP40 Flush-fit hollow walls distribution box 24 modules, transparent door and screwed neutral and earth bar
Exterior dimensions (Height x Width x Depth):	449x316x97 mm
Dimensions of the flush-fit gap (HxWxD):	421x288x72 mm
Number of modules:	2x12 (24) DIN rail
Installation:	Flush-fitted hollow walls
Color:	RAL 9003
Window:	Transparent
Weight (kg):	2,22
Cable entry:	Bottom: 1xM50/M40 4xM25/M20 5xM25/M16 - Rear: 2xM40/M32 4xM25 - Left: 3xØ32 - Right: 3xØ32
Components:	Cable section: 8x(2,5-6 mm ²)+8x(4-10 mm ²)+1x(10-25 mm ²)+1x(16-35 mm ²)
Materials:	Halogen-free plastic materials. Base: V0 PS. Frame: ABS
Lid-window-door material:	Tinted PC

Technical data:

Degree of protection:	IP40
Resistance to impact:	IK08
Glow wire resistance:	850 °C
Ball pressure test:	70 °C
Ambient temperature range:	-25 °C / +40 °C
Maximum operating voltage:	1000 V AC / 1500 V DC
Rated current:	125A
Double insulation:	Class II

Certificates and standards:

Directive:	2014/35/EU
Standards:	IEC 62208, IEC 61439-1
Certificates:	



Codes:

EAN:	8431044188416
Customs tariff number:	85.38.10.00
ETIM 8.0:	EC000214

GOLD FLUSH-FIT

IP40 FLUSH-FIT DISTRIBUTION BOXES HOLLOW WALLS

Description: IP40 FLUSH-FIT BOX 2x12 (24) MOD. PE+N

Reference: GPE24PT/PH/RR

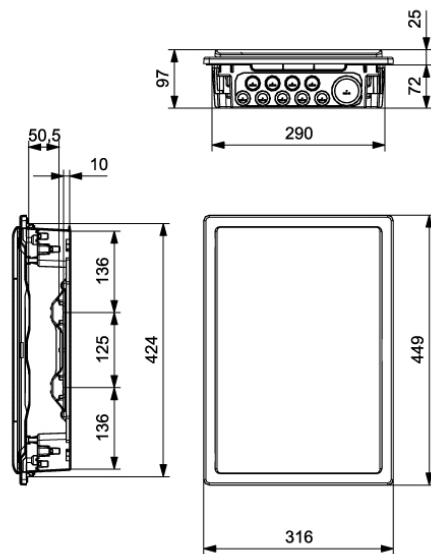

Detailed drawing:

 <http://www.ide.es/downloads/planos/pdf/GPE24PTPHRR.pdf>

 <http://www.ide.es/downloads/planos/dxf/GPE24PTPHRR.dxf>

 <http://www.ide.es/downloads/planos/stp/GPE24PTPHRR.stp>

Exterior dimensions (Height x Width x Depth):

449x316x97 mm

Dimensions of the flush-fit gap (Height x Width x Depth):

421x288x72 mm

Sustainability:

RoHS - REACH

Supply:

Supplied in individual cardboard packaging. When several items are sent together, they are bundled together with transparent film.

Packaging units: 8

Product end of life:

It does not require specific recycling operations.

Recommended applications:

Tertiary and residential sectors. For use indoors, specially designed for installation in pre-fabricated or plasterboard walls, flats, houses, offices, hotels, etc.