

Power Analyser

UMG 96 RM

Basic device

Extension UMG 96RM-PN

Extension UMG 96RM-P

Extension UMG 96RM-CBM

Modbus-address list
and Formulary

(from firmware rel. 1.14)

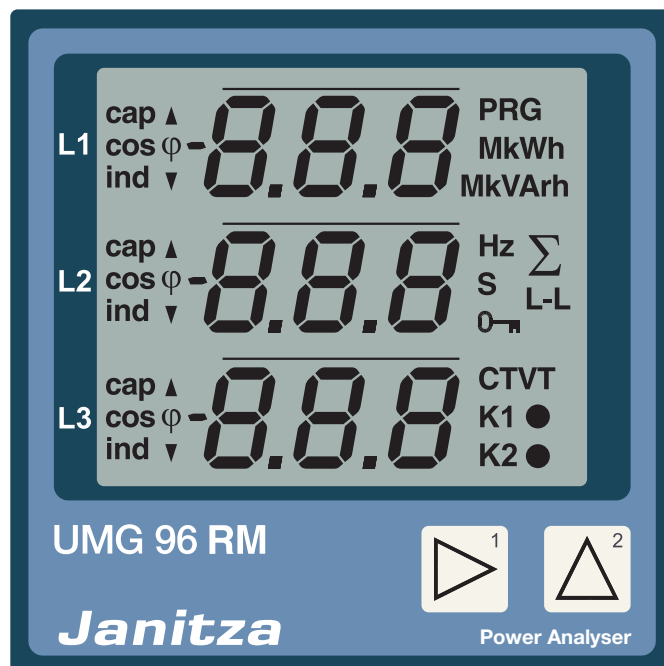

Content

Modbus	4
Modbus Functions (Slave)	4
Transfer parameters	5
Byte sequence	5
Update rate	5
Number formats	5
Symbols and definitions	5
Explanations of the measured values	6
Parameter	14
Address list	17
Frequently required readings	17
Measured values, type float	18
Measured values, type short	20
Mean values, type float	22
Mean values, type short	24
Minimum values, type float	26
Minimum values, type short	27
Maximum values, type float	28
Maximum values, type short	30
Maximum values of mean values, type float	32
Maximum values of mean values, type short	33
Energy, type Integer	34
Energy, type Float	38
Fourier analysis	42
Measured values, type float, fourier analysis	42
Measured values, type short, fourier analysis	48
Mean values, type float, fourier analysis	54
Mean values, type short, fourier analysis	60
Maximum values, type float, fourier analysis	66
Maximum values, type short, fourier analysis	72
Extension UMG 96RM-PN	78
Parameter	78
Measured values	79
Extension UMG 96RM-P / -CBM	80
Parameter	80
Limit value monitoring	82
Measured values, type float	86
Measured values, type short	86
Measured values, type integer	86
Mean values, type float	87
Mean values, type short	87

Maximum values, type float	88
Maximum values, type short	88
Minimum values, time stamp	89
Maximum values, time stamp	90
Peak indicator (drag indicator)	92
Fourier analysis	94
Measured values, typ float, fourier analysis	94
Measured values, typ short, fourier analysis	95
Mean values, typ float, fourier analysis	96
Mean values, typ short, fourier analysis	97
Maximum values, typ float, fourier analysis	98
Maximum values, typ short, fourier analysis	99

Copyright

This handbook is subject to the legal regulations of the copyright laws and may not be fully or partially photocopied, reprinted or reproduced mechanically or electronically and may not be copied or published in any other way without the legal, written permission of

Janitza electronics GmbH
 Vor dem Polstück 6
 35633 Lahnau
 Germany

Protected trademarks

All trademarks and the resulting rights belong to the respective owners of these rights.

Disclaimer

Janitza electronics GmbH does not accept any responsibility for errors or faults within this handbook and does not accept any obligation to keep the contents of this handbook updated.

Comments on the handbook

We welcome your comments. If anything appears to be unclear in this handbook, please let us know and send us an E-MAIL to: info@janitza.com

Modbus

Modbus Functions (Slave)

As a slave, the UMG 96RM supports the following modbus functions:

03 Read Holding Registers

Reads the binary contents of holding registers (4X references) in the slave.

04 Read Input Registers

Reads the binary contents of input registers (3X references) in the slave.

06 Preset Single Register

Presets a value into a single holding register (4X reference). When broadcast, the function presets the same register reference in all attached slaves.

16 (10Hex) Preset Multiple Registers

Presets values into a sequence of holding registers (4X references). When broadcast, the function presets the same register references in all attached slaves.

23 (17Hex) Read/Write 4X Registers

Performs a combination of one read and one write operation in a single Modbus transaction. The function can write new contents to a group of 4XXXX registers, and then return the contents of another group of 4XXXX registers. Broadcast is not supported.

Transfer parameters

The UMG 96RM supports the following transfer parameters:

Baud rate	: 9600, 19200, 38400, 57600 and 115200 Baud
Data bits	: 8
Parity	: none
Stop bits (UMG96RM)	: 2
Stop bits external	: 1 or 2

Byte sequence

The data in the modbus address list can be called up in the

- Big-Endian (high-Byte before low-Byte) and in the
- Little-Endian (low-byte before high-byte)

format.

The addresses described in this address list supply the data in the „Big-Endian“ format.

If you require the data in the „Little-Endian“ format, you must add the value 32768 to the address.

Update rate

The modbus register addresses are updated every 200ms.

Number formats

Type	Size	Minimum	Maximum
char	8 bit	0	255
byte	8 bit	-128	127
short	16 bit	-2^{15}	$2^{15} - 1$
int	32 bit	-2^{31}	$2^{31} - 1$
uint	32 bit	0	$2^{32} - 1$
long64	64 bit	-2^{63}	$2^{63} - 1$
float	32 bit	IEEE 754	IEEE 754
double	64 bit	IEEE 754	IEEE 754

Symbols and definitions

N	Total number of sample points per period (For example, in a period of 20 ms)
k	Sample value or number of samples per period ($0 \leq k < N$)
p	Number or identification of the phase conductor (p = 1, 2 oder 3)
ipk	Sample value k of the current of the phase conductor p
upNk	Sample value k of the neutral voltage of the phase conductor p
Pp	Real power of the phase conductor p

Explanations of the measured values

Measured value

- A measured value is a effective value which is formed over a period (measuring window) of 200ms.
- A measuring window is 10 periods in the 50Hz network and 12 periods in the 60Hz network.
- A measuring window has a start time and an end time.
- The resolution between the start time and end time is approximately 2ns.
- The accuracy of the start time and end time depends on the accuracy of the internal clock.
(Typically +- 1 minute/month)
- In order to improve the accuracy of the internal clock, it is recommended that the clock in the device is compared with a time service and reset.



The addresses in the range from 0-999 listed in this document can be adjusted directly on the device. The address range over 1,000 can only be edited via Modbus!

Measured values

- Measured values in short format do not take into account the set transducer ratios, i.e. these measured values must be multiplied by the corresponding transducer factor!
- Measured values in Float or Integer format consider the corresponding transducer factors!

Mean value of measured value

- For each measured value, a sliding mean value is calculated over the selected averaging time.
- The mean value is calculated every 200ms.
- You can take the possible averaging times from the table.

n	Mean time / seconds
0	5
1	10
2	15
3	30
4	60
5	300
6	480
7	600
8	900

Max. value of measured value

- The *max. value of the measured value* is the largest measured value which has occurred since the last deletion.

Min. value of measured value

- The *min. value of the measured value* is the lowest measured value which has occurred since the last deletion.

Max. value of mean value

- The *max. value of the mean value* is the largest mean value which has occurred since the last deletion.

Nominal current, voltage, frequency

- The limit values for events and transients are set by the nominal value in percentage.

Nominal current I_{rated}

- The I_{rated} is the nominal current of the transformers and is required for calculation of the K-factor.

Peak value negative

- Highest negative sampling value from the last 200ms measuring window..

Peak value positive

- Highest positive sampling value from the last 200ms measuring window.

Crest factor

- The crest factor describes the relation between the peak value and effective value of a periodic quantity. It serves as a characteristic value for general description of the curve form of a periodic quantity. The distortion factor is another example of a quantity for characterization of the difference from the pure sinusoidal form.
- Example: *A sinusoidal change voltage with an effective value of 230 V has a peak value of approx. 325 V. The crest factor is then $325 \text{ V} / 230 \text{ V} = 1.414$.*

Effective value of the current for phase conductor p

$$I_p = \sqrt{\frac{1}{N} \cdot \sum_{k=0}^{N-1} i_{pk}^2}$$

Effective value of neutral conductor current

$$I_N = \sqrt{\frac{1}{N} \cdot \sum_{k=0}^{N-1} (i_{1k} + i_{2k} + i_{3k})^2}$$

Effective voltage L-N

$$U_{pN} = \sqrt{\frac{1}{N} \cdot \sum_{k=0}^{N-1} u_{pNk}^2}$$

Effective voltage L-L

$$U_{pg} = \sqrt{\frac{1}{N} \cdot \sum_{k=0}^{N-1} (u_{gNk} - u_{pNk})^2}$$

Star connection voltage (vectorial)

$$U_{\text{Sternpunktspannung}} = U_{1\text{rms}} + U_{2\text{rms}} + U_{3\text{rms}}$$

Real power for phase conductor

$$P_p = \frac{1}{N} \cdot \sum_{k=0}^{N-1} (u_{pNk} \times i_{pk})$$

Apparent power for phase conductor

- Unsigned

$$S_p = U_{pN} \cdot I_p$$

Total apparent power (arithmetic) S_A

- Unsigned

$$S_A = S_1 + S_2 + S_3$$

Peak demand P_{\max}

- T = Periodic time
- t_n = n-th interval time
- P_n = n-th Power measurement value
- N = Number of measuring intervals in the period T

$$P_{\max} = \max \left(P_{\max}, \frac{1}{T} \sum_{n=1}^N (t_n \cdot P_n) \right)$$

Order number of harmonics

xxx[0] = mains frequency (50Hz/60Hz)
 xxx[1] = 2nd harmonic (100Hz/120Hz)
 xxx[2] = 3rd harmonic (150Hz/180Hz)
 etc.

THD

- THD (Total Harmonic Distortion) is the distortion factor and provides the relation of the harmonic parts of an oscillation to the mains frequency.

Distortion factor for the voltage

- M = 40 (UMG604, UMG508, UMG96RM)
- M = 50 (UMG605, UMG511)
- fund corresponds to n=1

$$THD_U = \frac{1}{|U_{fund}|} \sqrt{\sum_{n=2}^M |U_{n.Harm}|^2}$$

Distortion factor for the current

- M = 40 (UMG604, UMG508, UMG96RM)
- M = 50 (UMG605, UMG511)
- fund corresponds to n=1

$$THD_I = \frac{1}{|I_{fund}|} \sqrt{\sum_{n=2}^M |I_{n.Harm}|^2}$$

ZHD

- THD for the interharmonics.
- Is calculated in the product series and UMG511 UMG605.

Interharmonics

- Sinusoidal oscillations, which frequencies are not a multiple integer of the mains frequency.
- Is calculated in the product series and UMG511 UMG605.
- Calculation and measurement methods in accordance with the DIN EN 61000-4-30.
- The order number of inter harmonics corresponds to the order number of the next smallest harmonic. For example, between the 3rd and 4th harmonic of the 3rd inter harmonics.

TDD (I)

- TDD Total demand distortion, harmonic current distortion in % of maximum demand load current
- IL = Maximum demand load current
- M = 40 (UMG604, UMG508, UMG96RM)
- M = 50 (UMG605, UMG511)

$$TDD = \frac{1}{I_L} \sqrt{\sum_{n=2}^M I_n^2} \times 100\%$$

Ripple control signal U (EN61000-4-30)

The ripple control signal U is a voltage (200ms measured value) which is measured at a carrier frequency specified by the user. Only frequencies beneath 3kHz are observed.

Ripple control signal I

The ripple control signal I is a current (200ms measured value) which is measured at a carrier frequency specified by the user. Only frequencies beneath 3kHz are observed.

Positive sequence-negative sequence-zero sequence

- The extent of a voltage or current imbalance in a three-phase system is identified using the positive sequence, negative sequence and zero sequence components.
- The balance of the rotation current system strived for in normal operation is disturbed by the unsymmetrical loads, errors and equipment.
- A three-phase system is called symmetric, when the three phase conductor voltages and currents are the same size and are displaced against each other by 120°. If one or both conditions are not fulfilled, the system is described as unsymmetrical. By calculating the symmetrical components consisting of the positive sequence, negative sequence and zero sequence, the simplified analysis of an imbalanced error is possible in a rotary current system..
- Imbalance is a feature of the network quality for the limits specified in international norms (EN 50160 for example).

Positive sequence

$$U_{Mit} = \frac{1}{3} \left| U_{L1,fund} + U_{L2,fund} \cdot e^{j\frac{2\pi}{3}} + U_{L3,fund} \cdot e^{j\frac{4\pi}{3}} \right|$$

Negative sequence

$$U_{Geg} = \frac{1}{3} \left| U_{L1,fund} + U_{L2,fund} \cdot e^{-j\frac{2\pi}{3}} + U_{L3,fund} \cdot e^{-j\frac{4\pi}{3}} \right|$$

Zero sequence

$$U_{Nullsystem} = \frac{1}{3} \left| U_{L1,fund} + U_{L2,fund} + U_{L3,fund} \right|$$

A zero component can only occur if a sum current can flow back through the main conductor.

Voltage imbalance

$$Unsymmetrie = \frac{U_{Geg}}{U_{Mit}}$$

Under difference U (EN61000-4-30)

$$U_{unter} = \frac{U_{din} - \sqrt{\frac{\sum_{i=1}^n U_{rms-unter,i}^2}{n}}}{U_{din}} [\%]$$

Under difference I

$$I_{unter} = \frac{I_{Nennstrom} - \sqrt{\frac{\sum_{i=1}^n I_{rms-unter,i}^2}{n}}}{I_{Nennstrom}} [\%]$$

K-factor

- The K-factor describes the increase of the eddy current losses when loaded with harmonics. For a sinusoidal load on the transformer, the K-factor =1. The larger the K-factor, the heavier a transformer can be loaded with harmonics without overheating.

Power Factor (vectorial) - Lambda

- The power factor is unsigned.

$$PF_x = \frac{|P_x|}{S_x}$$

$x = L1, L2, L3, L4$

CosPhi - Fundamental Power Factor

- Only the mains frequency part is used for calculation of the cosphi.
- CosPhi sign:
 - = for the supply of real power
 - + = for obtaining real power

$$PF_1 = \cos(\varphi) = \frac{P_1}{S_1}$$

CosPhi total

- CosPhi sign:
 - = for the supply of real power
 - + = for obtaining real power

$$\cos(\varphi)_{Sum_3} = \frac{P_{1_fund} + P_{2_fund} + P_{3_fund}}{\sqrt{(P_{1_fund} + P_{2_fund} + P_{3_fund})^2 + (Q_{1_fund} + Q_{2_fund} + Q_{3_fund})^2}}$$

$$\cos(\varphi)_{Sum_4} = \frac{P_{1_fund} + P_{2_fund} + P_{3_fund} + P_{4_fund}}{\sqrt{(P_{1_fund} + P_{2_fund} + P_{3_fund} + P_{4_fund})^2 + (Q_{1_fund} + Q_{2_fund} + Q_{3_fund} + Q_{4_fund})^2}}$$

Phase Angle Phi

- The phase angle between current and voltage of the external conductor p is calculated according to DIN EN 61557-12 and displayed.
- The sign of the phase angle corresponding to the sign of the reactive power.

Mains frequency power factor

The mains frequency power factor is the power factor of the mains frequency and is calculated using the fourier analysis (FFT). The voltage and current must not be sinusoidal. All in the device calculated reactive power are resulting of fundamental reactive power.

Power factor sign

- Sign $Q = +1$ for phi in the range $0^\circ \dots 180^\circ$ (inductive)
- Sign $Q = -1$ for phi in the range $180^\circ \dots 360^\circ$ (capacitive)

$$\text{Vorzeichen } Q(\varphi_p) = +1 \text{ falls } \varphi_p \in [0^\circ - 180^\circ]$$

$$\text{Vorzeichen } Q(\varphi_p) = -1 \text{ falls } \varphi_p \in [180^\circ - 360^\circ]$$

Reactive power for phase conductor p

- Reactive power of the mains frequency.

$$Q_{fund p} = \text{Vorzeichen } Q(\varphi_p) \cdot \sqrt{S_{fund p}^2 - P_{fund p}^2}$$

Total reactive power

- Reactive power of the mains frequency.

$$Q_V = Q_1 + Q_2 + Q_3$$

Distortion power factor

- The distortion power factor is the power factor of all mains frequencies and is calculated using the fourier analysis (FFT).

$$D = \sqrt{S^2 - P^2 - Q_{fund}^2}$$

- The apparent power „S” contains all fundamental harmonics and all harmonic rates up to the M-th harmonic.
- The effective power „P” contains all fundamental harmonics and all harmonic rates up to the M-th harmonic.
- M = 50 (UMG605, UMG605-PRO, UMG511, UMG512-PRO)

Reactive energy per phase

$$E_{r_{L1}} = \int Q_{L1}(t) \cdot \Delta t$$

Reactive energy per phase, inductive

$$E_{r(ind)_{L1}} = \int Q_{L1}(t) \cdot \Delta t \quad \text{für } Q_{L1}(t) > 0$$

Reactive energy per phase, capacitive

$$E_{r(cap)_{L1}} = \int Q_{L1}(t) \cdot \Delta t \quad \text{für } Q_{L1}(t) < 0$$

Reactive energy, sum L1-L3

$$E_{r_{L1,L2,L3}} = \int (Q_{L1}(t) + Q_{L2}(t) + Q_{L3}(t)) \cdot \Delta t$$

Reactive energy, sum L1-L3, inductive

$$E_{r(ind)_{L1,L2,L3}} = \int (Q_{L1}(t) + Q_{L2}(t) + Q_{L3}(t)) \cdot \Delta t$$

für $(Q_{L1}(t) + Q_{L2}(t) + Q_{L3}(t)) > 0$

Reactive energy, sum L1-L3, capacitive

$$E_{r(cap)_{L1,L2,L3}} = \int (Q_{L1}(t) + Q_{L2}(t) + Q_{L3}(t)) \cdot \Delta t$$

für $(Q_{L1}(t) + Q_{L2}(t) + Q_{L3}(t)) < 0$

Tariff Conversion

The tariff conversion of the consumption meters is via the addresses 618 and 624.

- Select one of the tariffs 1 to 7 by setting or deleting bits 0 to 6.
- Bits 7 to 15 must never be set and must always be 0.
- Tariff 0 is always active and can never be switched off.
- Only the bit set with the lowest value is evaluated.

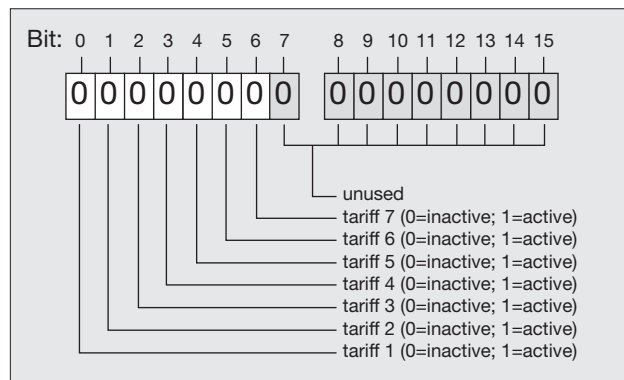

Example:

Activate tariff 3 for „Effective energy“ and „Effective energy drawn“.

- Set bit 2 to address 618.
The meters for „Effective energy“ are active.
- Set bit 2 to address 619.
The meters for „Effective energy drawn“ are active.

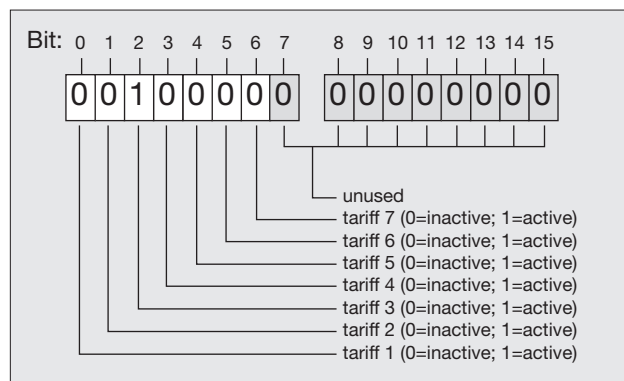

Example:

Setting tariff 3 and tariff 5 to one address at the same time.

- Set bit 2 and bit 4 to address 618.
Because only the bit set with the lowest value is evaluated, only tariff 3 is active; bit 4 for tariff 5 is ignored.
- The meters for „Effective energy“ (tariff 3) are active.

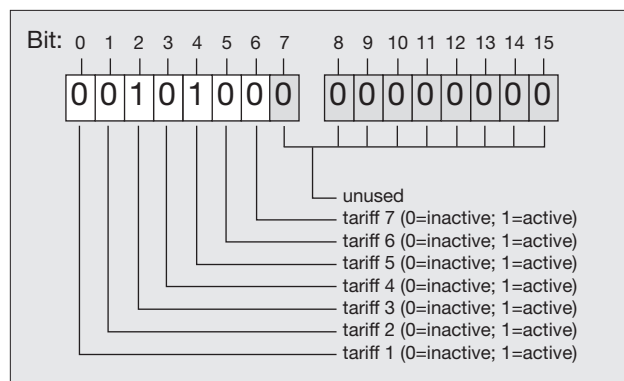

Parameter

These values can be set via the device buttons

Address	Format	RD/WR	Unit	Note	Adjustment Area	Default
0	SHORT	RD/WR	-	Device address	0..255 ⁽¹⁾	1
1	SHORT	RD/WR	kbps	Baudrate	0=9.6kbps 1=19.2kbps 2=38.4kbps 3=57.6kbps 4=115.2kbps	4
2	SHORT	RD/WR	-	Modbus Master (Master=1 only for version ethernet)	0,1	0
3	SHORT	RD/WR	-	Stop bits - 0=1 bit, no parity 1=2 bits, no parity 2=1 bit, even parity 3=1 bit, odd parity	0 .. 3	0
10	FLOAT	RD/WR	A	Current transformer I1, primary	0..1000000 ⁽²⁾	5
12	FLOAT	RD/WR	A	Current transformer I1, sec.	1..5	5
14	FLOAT	RD/WR	V	Voltage transformer V1, primary	0..1000000 ⁽²⁾	400
16	FLOAT	RD/WR	V	Voltage transformer V1, sec.	100, 400	400
18	FLOAT	RD/WR	A	Current transformer I2, primary	0..1000000 ⁽²⁾	5
20	FLOAT	RD/WR	A	Current transformer I2, sec.	1..5	5
22	FLOAT	RD/WR	V	Voltage transformer V2, primary	1..1000000	400
24	FLOAT	RD/WR	V	Voltage transformer V2, sec.	100, 400	400
26	FLOAT	RD/WR	A	Current transformer I3, primary	1..1000000	5
28	FLOAT	RD/WR	A	Current transformer I3, sec.	1..5	5
30	FLOAT	RD/WR	V	Voltage transformer V3, primary	1..1000000	400
32	FLOAT	RD/WR	V	Voltage transformer V3, sec.	100, 400	400
34	SHORT	RD/WR	Hz	Frequency determination 0=Auto, 45..65=Hz	0, 45..65	0
35	SHORT	RD/WR	-	Display contrast 0 (low), 9 (high)	0 .. 9	5
36	SHORT	RD/WR	-	Background lighting 0 (dark), 9 (bright)	0 .. 9	6
37	SHORT	RD/WR	-	Indication profile 0 .. 2 = Fix indication profiles 3 = Free selectable indication profile	0 .. 3	0
38	SHORT	RD/WR	-	Indication rotation profile 0 .. 2 = Fix indication rotation profiles 3 = Free selectable indication rotation profile	0 .. 3	0
39	SHORT	RD/WR	Sec.	Rotation time	0 .. 60	0
40	SHORT	RD/WR	-	Averaging time, I	0 .. 8*	6
41	SHORT	RD/WR	-	Averaging time, P	0 .. 8*	6
42	SHORT	RD/WR	-	Averaging time, U	0 .. 8*	6
43	FLOAT	RD/WR	A	Nominal current TDD	0 .. 1000000	150
45	INT	RD/WR	mA	Threshold, current measurement L1..L3	0 .. 200	5
50	SHORT	RD/WR	-	Password	0 .. 999	0 (no password)
100	SHORT	RD/WR	-	Address of measurement value, digital output 1	0 .. 32000	874
101	SHORT	RD/WR	-	Address of measurement value, digital output 2	0 .. 32000	882
102	FLOAT	RD/WR	-	Pulse valence, out 1	-1000000 .. + 1000000	1000
104	FLOAT	RD/WR	-	Pulse valence, out 2	-1000000 .. + 1000000	1000
106	SHORT	RD/WR	-	Min. pulse duration, digital output 1/2	1..1000	5
107	SHORT	RD/WR	-	Results of the Comparator group 1 combine A, B, C 1 = and, 0 = or	0, 1	
108	FLOAT	RD/WR	-	Comparator 1A, limit	-10 ¹² -1..+10 ¹² -1	

* 0 = 5Sec.; 1 = 10Sec.; 2 = 15Sec.; 3 = 30Sec.; 4 = 1Min.; 5 = 5Min.; 6 = 8Min.; 7 = 10Min.; 8 = 15Min.

⁽¹⁾ The values of 0 and 248 to 255 are reserved and should not be used.

⁽²⁾ The adjustable value of 0 for the primary power transformer results no useful work values and should not be used.

Address	Format	RD/WR	Unit	Note	Adjustment Area	Default
110	SHORT	RD/WR	-	Comparator 1A, Address of measurement value	0 .. 32000	
111	SHORT	RD/WR	Sec.	Comparator 1A, min. on time	0 .. 32000	
112	SHORT	RD/WR	Sec.	Comparator 1A, lead time	0 .. 32000	
113	SHORT	RD/WR	-	Comparator 1A, operator „>=“ = 0, „<“ = 1	0, 1	
114	FLOAT	RD/WR	-	Comparator 1B, limit	-10 ¹² -1..+10 ¹² -1	
116	SHORT	RD/WR	-	Comparator 1B, Address of measurement value	0 .. 32000	
117	SHORT	RD/WR	Sec.	Comparator 1B, min. on time	0 .. 32000	
118	SHORT	RD/WR	Sec.	Comparator 1B, lead time	0 .. 32000	
119	SHORT	RD/WR	-	Comparator 1B, operator „>=“ = 0, „<“ = 1	0, 1	
120	FLOAT	RD/WR	-	Comparator 1C, limit	-10 ¹² -1..+10 ¹² -1	
122	SHORT	RD/WR	-	Comparator 1C, Address of measurement value	0 .. 32000	
123	SHORT	RD/WR	Sec.	Comparator 1C, min. on time	0 .. 32000	
124	SHORT	RD/WR	Sec.	Comparator 1C, lead time	0 .. 32000	
125	SHORT	RD/WR	-	Comparator 1C, operator „>=“ = 0, „<“ = 1	0, 1	
126	SHORT	RD/WR	-	Results of the Comparator group 2 combine A, B, C 1 = and, 0 = or	0, 1	
127	FLOAT	RD/WR	-	Comparator 2A, limit	-10 ¹² -1..+10 ¹² -1	
129	SHORT	RD/WR	-	Comparator 2A, Address of measurement value	0 .. 32000	
130	SHORT	RD/WR	Sec.	Comparator 2A, min. on time	0 .. 32000	
131	SHORT	RD/WR	Sec.	Comparator 2A, lead time	0 .. 32000	
132	SHORT	RD/WR	-	Comparator 2A, operator „>=“ = 0, „<“ = 1	0, 1	
133	FLOAT	RD/WR	-	Comparator 2B, limit	-10 ¹² -1..+10 ¹² -1	
135	SHORT	RD/WR	-	Comparator 2B, Address of measurement value	0 .. 32000	
136	SHORT	RD/WR	Sec.	Comparator 2B, min. on time	0 .. 32000	
137	SHORT	RD/WR	Sec.	Comparator 2B, lead time	0 .. 32000	
138	SHORT	RD/WR	-	Comparator 2B, operator „>=“ = 0, „<“ = 1	0, 1	
139	FLOAT	RD/WR	-	Comparator 2C, limit	-10 ¹² -1..+10 ¹² -1	
141	SHORT	RD/WR	-	Comparator 2C, Address of measurement value	0 .. 32000	
142	SHORT	RD/WR	Sec.	Comparator 2C, min. on time	0 .. 32000	
143	SHORT	RD/WR	Sec.	Comparator 2C, lead time	0 .. 32000	
144	SHORT	RD/WR	-	Comparator 2C, operator „>=“ = 0, „<“ = 1	0, 1	
145	SHORT	RD/WR	-	„Display blinking“ Bit 1 = 1/0: active/inactive for comparator group output 1 Bit 2 = 1/0: active/inactive for comparator group output 2	0-3	0
200	SHORT	RD/WR	-	Source selection for DigitalOutput 1 0 = Comparator 1 1 = Pulse output (S0) 1 = External source - Modbus 2 = External source -Profibus (option) 3 = External source -Ethernet (option)	0 .. 4	1
201	SHORT	RD/WR	-	Output 1 inverted	0 .. 1	0
202	SHORT	RD/WR	-	Source selection for DigitalOutput 2 0 = Comparator 2 1 = Pulse output (S0) 1 = External source - Modbus 2 = External source -Profibus (option) 3 = External source -Ethernet (option)	0 .. 4	1
203	SHORT	RD/WR	-	Output 2 inverted	0 .. 1	0

Address	Format	RD/WR	Unit	Note	Adjustment Area	Default
300	String	RD/WR	-	Indication profile	GridVis	0
400	String	RD/WR	-	Indication rotation profile	GridVis	0
500	SHORT	RD/WR	-	Connection configuration, I L1	-3 .. 3	1
501	SHORT	RD/WR	-	Connection configuration, I L2	-3 .. 3	2
502	SHORT	RD/WR	-	Connection configuration, I L3 -1 = Measurement in phase L1, Connection (s1-s2) changed -2 = Measurement in phase L2, Connection (s1-s2) changed -3 = Measurement in phase L3, Connection (s1-s2) changed 0 = Channel switched off 1 = Measurement in phase L1 2 = Measurement in phase L2 3 = Measurement in phase L3	-3 .. 3	3
503	SHORT	RD/WR	-	Connection configuration, U L1	0 .. 3	1
504	SHORT	RD/WR	-	Connection configuration, U L2	0 .. 3	2
505	SHORT	RD/WR	-	Connection configuration, U L3 0 = Channel switched off 1 = Measurement in phase L1 2 = Measurement in phase L2 3 = Measurement in phase L3	0 .. 3	3
506	SHORT	RD/WR	-	Delete min. and maximum values	0..1	0
507	SHORT	RD/WR	-	Delete energy values	0..1	0
508	SHORT	RD/WR	-	Write in EEPROM	0..1	0
509	SHORT	RD/WR	-	Connection diagram voltage	0.8 ¹⁾	0
510	SHORT	RD/WR	-	Connection diagram current	0..8	0
511	SHORT	RD/WR	-	Relevant voltage, for THD and FFT display of THD and FFT 0=THD L-N, FFT L-N 1=THD L-L, FFT L-L	0..1	0
512	SHORT	RD/WR	-	Year *	0..99	
513	SHORT	RD/WR	-	Month *	0..12	
514	SHORT	RD/WR	-	Day *	0..31	
515	SHORT	RD/WR	-	Hour *	0..24	
516	SHORT	RD/WR	-	Minute *	0..59	
517	SHORT	RD/WR	-	Second *	0..59	
600	UINT	RD/WR	-	Overrange	0, 0xFFFFFFFF	
602	SHORT	RD/WR	-	Modbus value for output 1	0..1	
605	SHORT	RD/WR	-	Modbus-value for output 2	0..1	
608	SHORT	RD	-	Condition output 1		
609	SHORT	RD	-	Condition output 2		
610	SHORT	RD	-	Comparator 1 output A		
611	SHORT	RD	-	Comparator 1 output B		
612	SHORT	RD	-	Comparator 1 output C		
613	SHORT	RD	-	Comparator 2 output A		
614	SHORT	RD	-	Comparator 2 output B		
615	SHORT	RD	-	Comparator 2 output C		
616	SHORT	RD	-	Linkage result of comparator group 1		
617	SHORT	RD	-	Linkage result of comparator group 2		
618	SHORT	RD/WR	-	Rate, real energy**	0..127	0
619	SHORT	RD/WR	-	Rate, real energy consumed**	0..127	0
620	SHORT	RD/WR	-	Rate, real energy delivered**	0..127	0
621	SHORT	RD/WR	-	Rate, reactive energy**	0..127	0
622	SHORT	RD/WR	-	Rate, reactive energy inductive**	0..127	0
623	SHORT	RD/WR	-	Rate, reactive energy capacitive**	0..127	0
624	SHORT	RD/WR	-	Rate, apparent energy**	0..127	0
750	SHORT	RD	-	Software release		
754	SERNR	RD	-	Serial number		
756	SERNR	RD	-	Production number		
761	USHORT	RD	-	Module number (0=no module, 1=Profibus, 2=CBM, 3=Ethernet)		

Address list

Frequently required readings

Address	Format	RD/WR	Unit	Note	Index
19000	FLOAT	RD	V	Voltage L1-N	[0]
19002	FLOAT	RD	V	Voltage L2-N	[1]
19004	FLOAT	RD	V	Voltage L3-N	[2]
19006	FLOAT	RD	V	Voltage L1-L2	[0]
19008	FLOAT	RD	V	Voltage L2-L3	[1]
19010	FLOAT	RD	V	Voltage L1-L3	[2]
19012	FLOAT	RD	A	Current I L1	[0]
19014	FLOAT	RD	A	Current I L2	[1]
19016	FLOAT	RD	A	Current I L3	[2]
19018	FLOAT	RD	A	Vector sum; $IN=I1+I2+I3$	[3]
19020	FLOAT	RD	W	Real power P1 L1N	[0]
19022	FLOAT	RD	W	Real power P2 L2N	[1]
19024	FLOAT	RD	W	Real power P3 L3N	[2]
19026	FLOAT	RD	W	Sum; $Psum3=P1+P2+P3$	[3]
19028	FLOAT	RD	VA	Apparent power S1 L1N	[0]
19030	FLOAT	RD	VA	Apparent power S2 L2N	[1]
19032	FLOAT	RD	VA	Apparent power S3 L3N	[2]
19034	FLOAT	RD	VA	Sum; $Ssum3=S1+S2+S3$	[3]
19036	FLOAT	RD	var	Fund. reactive power Q1 L1N	[0]
19038	FLOAT	RD	var	Fund. reactive power Q2 L2N	[1]
19040	FLOAT	RD	var	Fund. reactive power Q3 L3N	[2]
19042	FLOAT	RD	var	Sum; $Qsum3=Q1+Q2+Q3$	[3]
19044	FLOAT	RD	-	CosPhi; UL1 IL1 (fundamental comp.)	[0]
19046	FLOAT	RD	-	CosPhi; UL2 IL2 (fundamental comp.)	[1]
19048	FLOAT	RD	-	CosPhi; UL3 IL3 (fundamental comp.)	[2]
19050	FLOAT	RD	Hz	Measured frequency	
19052	FLOAT	RD	-	Rotation field; 1=right, 0=none, -1=left	
19054	FLOAT	RD	Wh	Real energy L1	[0]
19056	FLOAT	RD	Wh	Real energy L2	[0]
19058	FLOAT	RD	Wh	Real energy L3	[0]
19060	FLOAT	RD	Wh	Real energy L1..L3	[0]
19062	FLOAT	RD	Wh	Real energy L1, consumed	[0]
19064	FLOAT	RD	Wh	Real energy L2, consumed	[0]
19066	FLOAT	RD	Wh	Real energy L3, consumed	[0]
19068	FLOAT	RD	Wh	Real energy L1..L3, consumed, rate 1	[1]
19070	FLOAT	RD	Wh	Real energy L1, delivered	[0]
19072	FLOAT	RD	Wh	Real energy L2, delivered	[0]
19074	FLOAT	RD	Wh	Real energy L3, delivered	[0]
19076	FLOAT	RD	Wh	Real energy L1..L3, delivered	[0]
19078	FLOAT	RD	VAh	Apparent energy L1	[0]
19080	FLOAT	RD	VAh	Apparent energy L2	[0]
19082	FLOAT	RD	VAh	Apparent energy L3	[0]
19084	FLOAT	RD	VAh	Apparent energy L1..L3	[0]
19086	FLOAT	RD	varh	Reactive energy L1	[0]
19088	FLOAT	RD	varh	Reactive energy L2	[0]
19090	FLOAT	RD	varh	Reactive energy L3	[0]
19092	FLOAT	RD	varh	Reactive energy L1..L3	[0]
19094	FLOAT	RD	varh	Reactive energy ind. L1	[0]
19096	FLOAT	RD	varh	Reactive energy ind. L2	[0]
19098	FLOAT	RD	varh	Reactive energy ind. L3	[0]
19100	FLOAT	RD	varh	Reactive energy ind. L1..L3	[0]
19102	FLOAT	RD	varh	Reactive energy cap. L1	[0]
19104	FLOAT	RD	varh	Reactive energy cap. L2	[0]
19106	FLOAT	RD	varh	Reactive energy cap. L3	[0]
19108	FLOAT	RD	varh	Reactive energy cap. L1..L3	[0]
19110	FLOAT	RD	%	Harmonic, THD U L1-N	[0]
19112	FLOAT	RD	%	Harmonic, THD U L2-N	[1]
19114	FLOAT	RD	%	Harmonic, THD U L3-N	[2]
19116	FLOAT	RD	%	Harmonic, THD I L1	[0]
19118	FLOAT	RD	%	Harmonic, THD I L2	[1]
19120	FLOAT	RD	%	Harmonic, THD I L3	[2]

Measured values, type float

Address	Format	RD/WR	Unit	Note	Index
800	FLOAT	RD	Hz	Measured frequency	
802	FLOAT	RD	-	Voltage, zero sequence	
804	FLOAT	RD	-	Voltage, negative sequence	
806	FLOAT	RD	-	Voltage, positive sequence	
808	FLOAT	RD	V	Voltage U1 L1-N	[0]
810	FLOAT	RD	V	Voltage U2 L2-N	[1]
812	FLOAT	RD	V	Voltage U3 L3-N	[2]
814	FLOAT	RD	V	Voltage U1 L1-L2	[0]
816	FLOAT	RD	V	Voltage U2 L2-L3	[1]
818	FLOAT	RD	V	Voltage U3 L3-L1	[2]
820	FLOAT	RD	-	Fund. power factor, CosPhi; ULN, IL1	[0]
822	FLOAT	RD	-	Fund. power factor, CosPhi; ULN, IL2	[1]
824	FLOAT	RD	-	Fund. power factor, CosPhi; ULN, IL3	[2]
826	FLOAT	RD	-	Sum; CosPhisum3=P0sum3/Ssum3	[3]
828	FLOAT	RD	-	Power factor; UL1N, IL1	[0]
830	FLOAT	RD	-	Power factor; UL2N, IL2	[1]
832	FLOAT	RD	-	Power factor; UL3N, IL3	[2]
834	FLOAT	RD	-	Sum; Power factor sum3=Psum3/Ssum3	[3]
836	FLOAT	RD	%	THD, U L1N, bezogen auf U0 L1	[0]
838	FLOAT	RD	%	THD, U L2N, bezogen auf U0 L2	[1]
840	FLOAT	RD	%	THD, U L3N, bezogen auf U0 L3	[2]
842	FLOAT	RD	%	THD, U L1L2, bezogen auf U0 L1L2	[0]
844	FLOAT	RD	%	THD, U L2L3, bezogen auf U0 L2L3	[1]
846	FLOAT	RD	%	THD, U L3L1, bezogen auf U0 L3L1	[2]
848	FLOAT	RD	V	Voltage, real part U1 L1N	[0]
850	FLOAT	RD	V	Voltage, real part U2 L2N	[1]
852	FLOAT	RD	V	Voltage, real part U3 L3N	[2]
854	FLOAT	RD	V	Voltage, imaginary part U L1N	[0]
856	FLOAT	RD	V	Voltage, imaginary part U L2N	[1]
858	FLOAT	RD	V	Voltage, imaginary part U L3N	[2]
860	FLOAT	RD	A	Current I1 L1	[0]
862	FLOAT	RD	A	Current I2 L2	[1]
864	FLOAT	RD	A	Current I3 L3	[2]
866	FLOAT	RD	A	Vector sum; IN=I1+I2+I3	[3]
868	FLOAT	RD	W	Real power P1 L1N	[0]
870	FLOAT	RD	W	Real power P2 L2N	[1]
872	FLOAT	RD	W	Real power P3 L3N	[2]
874	FLOAT	RD	W	Sum; Psum3=P1+P2+P3	[3]
876	FLOAT	RD	var	Fund. reactive power Q1 L1N	[0]
878	FLOAT	RD	var	Fund. reactive power Q2 L2N	[1]
880	FLOAT	RD	var	Fund. reactive power Q3 L3N	[2]
882	FLOAT	RD	var	Sum; Qsum3=Q1+Q2+Q3	[3]
884	FLOAT	RD	VA	Apparent power S1 L1N	[0]
886	FLOAT	RD	VA	Apparent power S2 L2N	[1]
888	FLOAT	RD	VA	Apparent power S3 L3N	[2]
890	FLOAT	RD	VA	Sum; Ssum3=S1+S2+S3	[3]
892	FLOAT	RD	W	Fund. real power P01 L1N	[0]
894	FLOAT	RD	W	Fund. real power P02 L2N	[1]
896	FLOAT	RD	W	Fund. real power P03 L3N	[2]
898	FLOAT	RD	W	Sum; P0sum3=P01+P02+P03	[3]
900	FLOAT	RD	var	Harmonic distortion power D1 L1N	[0]
902	FLOAT	RD	var	Harmonic distortion power D2 L2N	[1]
904	FLOAT	RD	var	Harmonic distortion power D3 L3N	[2]
906	FLOAT	RD	var	Sum; Dsum3=D1+D2+D3	[3]
908	FLOAT	RD	%	THDI1 I1, bezogen auf I01	[0]
910	FLOAT	RD	%	THDI2 I2, bezogen auf I02	[1]
912	FLOAT	RD	%	THDI3 I3, bezogen auf I03	[2]
914	FLOAT	RD	%	TDDI1 I1, bezogen auf den Nenn-Laststrom	[0]
916	FLOAT	RD	%	TDDI2 I2, bezogen auf den Nenn-Laststrom	[1]
918	FLOAT	RD	%	TDDI3 I3, bezogen auf den Nenn-Laststrom	[2]
920	FLOAT	RD	-	Current, zero sequence	
922	FLOAT	RD	-	Current, negative sequence	
924	FLOAT	RD	-	Current, positive sequence	
926	FLOAT	RD	A	Current, real part I L1	[0]
928	FLOAT	RD	A	Current, real part I L2	[1]
930	FLOAT	RD	A	Current, real part I L3	[2]

Address	Format	RD/WR	Unit	Note	Index
932	FLOAT	RD	A	Current, imaginary part I L	[0]
934	FLOAT	RD	A	Current, imaginary part I L	[1]
936	FLOAT	RD	A	Current, imaginary part I L	[2]
938	FLOAT	RD	-	Rotation field; 1=right, 0=none, -1=left	
940	FLOAT	RD	Hz	Frequency 200 ms	
6154	FLOAT	RD		Crest factor, U L1	
6156	FLOAT	RD		Crest factor, U L2	
6158	FLOAT	RD		Crest factor, U L3	
6160	FLOAT	RD		Crest factor, I L1	
6162	FLOAT	RD		Crest factor, I L2	
6164	FLOAT	RD		Crest factor, I L3	

Measured values, type short (not available for UMG 96RM-PN) *

The measured values in short format do not contain current and voltage transformer ratios.

Address	Format	RD/WR	Unit	Note	Index	Resolution
3526	SHORT	RD	Hz	measured frequency		0,01
3527	SHORT	RD	V	Voltage, zero sequence		0,1
3528	SHORT	RD	V	Voltage, negative sequence		0,1
3529	SHORT	RD	V	Voltage, positive sequence		0,1
3530	SHORT	RD	V	Voltage U1 L1-N	[0]	0,1
3531	SHORT	RD	V	Voltage U2 L2-N	[1]	0,1
3532	SHORT	RD	V	Voltage U3 L3-N	[2]	0,1
3533	SHORT	RD	V	Voltage U1 L1-L2	[0]	0,1
3534	SHORT	RD	V	Voltage U2 L2-L3	[1]	0,1
3535	SHORT	RD	V	Voltage U3 L3-L1	[2]	0,1
3776	SHORT	RD	-	Fund. power factor, CosPhi; ULN IL	[0]	0,01
3777	SHORT	RD	-	Fund. power factor, CosPhi; ULN IL	[1]	0,01
3778	SHORT	RD	-	Fund. power factor, CosPhi; ULN IL	[2]	0,01
3779	SHORT	RD	-	Sum; CosPhisum3=P0sum3/Ssum3	[3]	0,01
3780	SHORT	RD	-	Power factor; ULN IL	[0]	0,01
3781	SHORT	RD	-	Power factor; ULN IL	[1]	0,01
3782	SHORT	RD	-	Power factor; ULN IL	[2]	0,01
3783	SHORT	RD	-	Sum; Power factor sum3=Psum3/Ssum3	[3]	
3784	SHORT	RD	%	THD U LN	[0]	0,1
3785	SHORT	RD	%	THD U LN	[1]	0,1
3786	SHORT	RD	%	THD U LN	[2]	0,1
3787	SHORT	RD	%	THD U LL	[0]	0,1
3788	SHORT	RD	%	THD U LL	[1]	0,1
3789	SHORT	RD	%	THD U LL	[2]	0,1
3790	SHORT	RD	V	Voltage, real part U LN	[0]	0,1
3791	SHORT	RD	V	Voltage, real part U LN	[1]	0,1
3792	SHORT	RD	V	Voltage, real part U LN	[2]	0,1
3793	SHORT	RD	V	Voltage, imaginary part U LN	[0]	0,1
3794	SHORT	RD	V	Voltage, imaginary part U LN	[1]	0,1
3795	SHORT	RD	V	Voltage, imaginary part U LN	[2]	0,1
3916	SHORT	RD	mA	Current I L	[0]	1
3917	SHORT	RD	mA	Current I L	[1]	1
3918	SHORT	RD	mA	Current I L	[2]	1
3919	SHORT	RD	mA	Vector sum; IN=I1+I2+I3	[3]	1
3920	SHORT	RD	W	Real power P LN	[0]	0,1
3921	SHORT	RD	W	Real power P LN	[1]	0,1
3922	SHORT	RD	W	Real power P LN	[2]	0,1
3923	SHORT	RD	W	Sum; Psum3=P1+P2+P3	[3]	0,1
3924	SHORT	RD	var	Fund. reactive power Q LN	[0]	0,1
3925	SHORT	RD	var	Fund. reactive power Q LN	[1]	0,1
3926	SHORT	RD	var	Fund. reactive power Q LN	[2]	0,1
3927	SHORT	RD	var	Sum; Qsum3=Q1+Q2+Q3	[3]	0,1
3928	SHORT	RD	VA	Apparent power S LN	[0]	0,1
3929	SHORT	RD	VA	Apparent power S LN	[1]	0,1
3930	SHORT	RD	VA	Apparent power S LN	[2]	0,1
3931	SHORT	RD	VA	Sum; Ssum3=S1+S2+S3	[3]	0,1
3932	SHORT	RD	W	Fund. real power P0 LN	[0]	0,1
3933	SHORT	RD	W	Fund. real power P0 LN	[1]	0,1
3934	SHORT	RD	W	Fund. real power P0 LN	[2]	0,1
3935	SHORT	RD	W	Sum; CosPhisum3=P0sum3/Ssum3	[3]	0,1
3936	SHORT	RD	var	Harmonic distortion power D LN	[0]	0,1
3937	SHORT	RD	var	Harmonic distortion power D LN	[1]	0,1
3938	SHORT	RD	var	Harmonic distortion power D LN	[2]	0,1
3939	SHORT	RD	var	Sum; Dsum3=D1+D2+D3	[3]	0,1
3940	SHORT	RD	%	THD I	[0]	0,1
3941	SHORT	RD	%	THD I	[1]	0,1
3942	SHORT	RD	%	THD I	[2]	0,1
3943	SHORT	RD	%	TDD I	[0]	0,1
3944	SHORT	RD	%	TDD I	[1]	0,1
3945	SHORT	RD	%	TDD I	[2]	0,1
3946	SHORT	RD	mA	Current, zero sequence		1
3947	SHORT	RD	mA	Current, negative sequence		1
3948	SHORT	RD	mA	Current, positive sequence		1
3949	SHORT	RD	mA	Current, real part I L	[0]	1
3950	SHORT	RD	mA	Current, real part I L	[1]	1
3951	SHORT	RD	mA	Current, real part I L	[2]	1

Address	Format	RD/WR	Unit	Note	Index	Resolution
3952	SHORT	RD	mA	Current, imaginary part I L	[0]	1
3953	SHORT	RD	mA	Current, imaginary part I L	[1]	1
3954	SHORT	RD	mA	Current, imaginary part I L	[2]	1
3955	SHORT	RD	-	Rotation field; 1=right, 0=none, -1=left		
4858	SHORT	RD	Hz	Frequency 200 ms, Integer		0,01

* These measured values (address range 3526-4851 and 4858-4861) cannot be read out via the Profinet module of the UMG 96RM-PN. Reading out these measured values via the RS485 interface is supported.

Mean values, type float

Address	Format	RD/WR	Unit	Note	Index
1720	FLOAT	RD	Hz	Average, measured frequency	
1722	FLOAT	RD	-	Average, Voltage, zero sequence	
1724	FLOAT	RD	-	Average, Voltage, negative sequence	
1726	FLOAT	RD	-	Average, Voltage, positive sequence	
1728	FLOAT	RD	V	Average, Voltage LN	[0]
1730	FLOAT	RD	V	Average, Voltage LN	[1]
1732	FLOAT	RD	V	Average, Voltage LN	[2]
1734	FLOAT	RD	V	Average, Voltage LL	[0]
1736	FLOAT	RD	V	Average, Voltage LL	[1]
1738	FLOAT	RD	V	Average, Voltage LL	[2]
2220	FLOAT	RD	-	Average, Fund. power factor, CosPhi; ULN IL	[0]
2222	FLOAT	RD	-	Average, Fund. power factor, CosPhi; ULN IL	[1]
2224	FLOAT	RD	-	Average, Fund. power factor, CosPhi; ULN IL	[2]
2226	FLOAT	RD	-	Average, Sum; CosPhisum3=P0sum3/Ssum3	[3]
2228	FLOAT	RD	-	Average, Power factor; ULN IL	[0]
2230	FLOAT	RD	-	Average, Power factor; ULN IL	[1]
2232	FLOAT	RD	-	Average, Power factor; ULN IL	[2]
2234	FLOAT	RD	-	Average, Sum; Power factor sum3=Psum3/Ssum3	[3]
2236	FLOAT	RD	V	Average, THD, U LN	[0]
2238	FLOAT	RD	V	Average, THD, U LN	[1]
2240	FLOAT	RD	V	Average, THD, U LN	[2]
2242	FLOAT	RD	V	Average, THD, U LL	[0]
2244	FLOAT	RD	V	Average, THD, U LL	[1]
2246	FLOAT	RD	V	Average, THD, U LL	[2]
2248	FLOAT	RD	V	Average, Voltage, real part U LN	[0]
2250	FLOAT	RD	V	Average, Voltage, real part U LN	[1]
2252	FLOAT	RD	V	Average, Voltage, real part U LN	[2]
2254	FLOAT	RD	V	Average, Voltage, imaginary part U LN	[0]
2256	FLOAT	RD	V	Average, Voltage, imaginary part U LN	[1]
2258	FLOAT	RD	V	Average, Voltage, imaginary part U LN	[2]
2500	FLOAT	RD	A	Average, Current IL	[0]
2502	FLOAT	RD	A	Average, Current IL	[1]
2504	FLOAT	RD	A	Average, Current IL	[2]
2506	FLOAT	RD	A	Average, Vector sum; IN=I1+I2+I3	[3]
2508	FLOAT	RD	W	Average, Real power P LN	[0]
2510	FLOAT	RD	W	Average, Real power PLN	[1]
2512	FLOAT	RD	W	Average, Real power P LN	[2]
2514	FLOAT	RD	W	Average, Sum; Psum3=P1+P2+P3	[3]
2516	FLOAT	RD	var	Average, Fund. reactive power Q LN	[0]
2518	FLOAT	RD	var	Average, Fund. reactive power Q LN	[1]
2520	FLOAT	RD	var	Average, Fund. reactive power Q LN	[2]
2522	FLOAT	RD	var	Average, Sum; Qsum3=Q1+Q2+Q3	[3]
2524	FLOAT	RD	VA	Average, Apparent power S LN	[0]
2526	FLOAT	RD	VA	Average, Apparent power S LN	[1]
2528	FLOAT	RD	VA	Average, Apparent power S LN	[2]
2530	FLOAT	RD	VA	Average, Sum; Ssum3=S1+S2+S3	[3]
2532	FLOAT	RD	W	Average, Fund. real power P0 LN	[0]
2534	FLOAT	RD	W	Average, Fund. real power P0 LN	[1]
2536	FLOAT	RD	W	Average, Fund. real power P0 LN	[2]
2538	FLOAT	RD	W	Average, Sum; CosPhisum3=P0sum3/Ssum3	[3]
2540	FLOAT	RD	var	Average, Harmonic distortion power D LN	[0]
2542	FLOAT	RD	var	Average, Harmonic distortion power D LN	[1]
2544	FLOAT	RD	var	Average, Harmonic distortion power D LN	[2]
2546	FLOAT	RD	var	Average, Sum; Dsum3=D1+D2+D3	[3]
2548	FLOAT	RD	%	Average, THD I	[0]
2550	FLOAT	RD	%	Average, THD I	[1]
2552	FLOAT	RD	%	Average, THD I	[2]
2554	FLOAT	RD	%	Average, TDD I	[0]
2556	FLOAT	RD	%	Average, TDD I	[1]
2558	FLOAT	RD	%	Average, TDD I	[2]
2560	FLOAT	RD	-	Average, Current, zero sequence	
2562	FLOAT	RD	-	Average, Current, negative sequence	
2564	FLOAT	RD	-	Average, Current, positive sequence	
2566	FLOAT	RD	A	Average, Current, real part I L	[0]
2568	FLOAT	RD	A	Average, Current, real part I L	[1]
2570	FLOAT	RD	A	Average, Current, real part I L	[2]

Address	Format	RD/WR	Unit	Note	Index
2572	FLOAT	RD	A	Average, Current, imaginary part IL	[0]
2574	FLOAT	RD	A	Average, Current, imaginary part IL	[1]
2576	FLOAT	RD	A	Average, Current, imaginary part IL	[2]
4852	FLOAT	RD	Hz	Average, frequency 200 ms	

Mean values, type short (not available for UMG 96RM-PN) *

The measured values in short format do not contain current and voltage transformer ratios.

Address	Format	RD/WR	Unit	Note	Index	Resolution
3956	SHORT	RD	Hz	Average, measured frequency		0,01
3957	SHORT	RD	V	Average, Voltage, zero sequence		0,1
3958	SHORT	RD	V	Average, Voltage, negative sequence		0,1
3959	SHORT	RD	V	Average, Voltage, positive sequence		0,1
3960	SHORT	RD	V	Average, Voltage L-N	[0]	0,1
3961	SHORT	RD	V	Average, Voltage L-N	[1]	0,1
3962	SHORT	RD	V	Average, Voltage L-N	[2]	0,1
3963	SHORT	RD	V	Average, Voltage L-L	[0]	0,1
3964	SHORT	RD	V	Average, Voltage L-L	[1]	0,1
3965	SHORT	RD	V	Average, Voltage L-L	[2]	0,1
4206	SHORT	RD	-	Average, Fund. power factor, CosPhi; ULN IL	[0]	0,01
4207	SHORT	RD	-	Average, Fund. power factor, CosPhi; ULN IL	[1]	0,01
4208	SHORT	RD	-	Average, Fund. power factor, CosPhi; ULN IL	[2]	0,01
4209	SHORT	RD	-	Average, Sum; CosPhisum3=P0sum3/Ssum3	[3]	0,01
4210	SHORT	RD	-	Average, Power factor; ULN IL	[0]	0,01
4211	SHORT	RD	-	Average, Power factor; ULN IL	[1]	0,01
4212	SHORT	RD	-	Average, Power factor; ULN IL	[2]	0,01
4213	SHORT	RD	-	Average, Sum; Power factor sum3=Psum3/Ssum3	[3]	
4214	SHORT	RD	%	Average, THD U LN	[0]	0,1
4215	SHORT	RD	%	Average, THD U LN	[1]	0,1
4216	SHORT	RD	%	Average, THD U LN	[2]	0,1
4217	SHORT	RD	%	Average, THD U LL	[0]	0,1
4218	SHORT	RD	%	Average, THD U LL	[1]	0,1
4219	SHORT	RD	%	Average, THD U LL	[2]	0,1
4220	SHORT	RD	V	Average, real part U LN	[0]	0,1
4221	SHORT	RD	V	Average, real part U LN	[1]	0,1
4222	SHORT	RD	V	Average, real part U LN	[2]	0,1
4223	SHORT	RD	V	Average, imaginary part U LN	[0]	0,1
4224	SHORT	RD	V	Average, imaginary part U LN	[1]	0,1
4225	SHORT	RD	V	Average, imaginary part U LN	[2]	0,1
4346	SHORT	RD	mA	Average, Current I L	[0]	1
4347	SHORT	RD	mA	Average, Current I L	[1]	1
4348	SHORT	RD	mA	Average, Current I L	[2]	1
4349	SHORT	RD	mA	Average, Vector sum; IN=I1+I2+I3	[3]	1
4350	SHORT	RD	W	Average, Real power P LN	[0]	0,1
4351	SHORT	RD	W	Average, Real power P LN	[1]	0,1
4352	SHORT	RD	W	Average, Real power P LN	[2]	0,1
4353	SHORT	RD	W	Average, Sum; Psum3=P1+P2+P3	[3]	0,1
4354	SHORT	RD	var	Average, Fund. reactive power Q LN	[0]	0,1
4355	SHORT	RD	var	Average, Fund. reactive power Q LN	[1]	0,1
4356	SHORT	RD	var	Average, Fund. reactive power Q LN	[2]	0,1
4357	SHORT	RD	var	Average, Sum; Qsum3=Q1+Q2+Q3	[3]	0,1
4358	SHORT	RD	VA	Average, Apparent power S LN	[0]	0,1
4359	SHORT	RD	VA	Average, Apparent power S LN	[1]	0,1
4360	SHORT	RD	VA	Average, Apparent power S LN	[2]	0,1
4361	SHORT	RD	VA	Average, Sum; Ssum3=S1+S2+S3	[3]	0,1
4362	SHORT	RD	W	Average, Fund. real power P0 LN	[0]	0,1
4363	SHORT	RD	W	Average, Fund. real power P0 LN	[1]	0,1
4364	SHORT	RD	W	Average, Fund. real power P0 LN	[2]	0,1
4365	SHORT	RD	W	Average, Sum; CosPhisum3=P0sum3/Ssum3	[3]	0,1
4366	SHORT	RD	var	Average, Harmonic distortion power D LN	[0]	0,1
4367	SHORT	RD	var	Average, Harmonic distortion power D LN	[1]	0,1
4368	SHORT	RD	var	Average, Harmonic distortion power D LN	[2]	0,1
4369	SHORT	RD	var	Average, Sum; Dsum3=D1+D2+D3	[3]	0,1
4370	SHORT	RD	%	Average, THD I	[0]	0,1
4371	SHORT	RD	%	Average, THD I	[1]	0,1
4372	SHORT	RD	%	Average, THD I	[2]	0,1
4373	SHORT	RD	%	Average, TDD I	[0]	0,1
4374	SHORT	RD	%	Average, TDD I	[1]	0,1
4375	SHORT	RD	%	Average, TDD I	[2]	0,1
4376	SHORT	RD	mA	Average, Current, zero sequence		1
4377	SHORT	RD	mA	Average, Current, negative sequence		1
4378	SHORT	RD	mA	Average, Current, positive sequence		1
4379	SHORT	RD	mA	Average, Current, real part I L	[0]	1
4380	SHORT	RD	mA	Average, Current, real part I L	[1]	1
4381	SHORT	RD	mA	Average, Current, real part I L	[2]	1

Address	Format	RD/WR	Unit	Note	Index	Resolution
4382	SHORT	RD	A	Average, Current, imaginary part I L	[0]	1
4383	SHORT	RD	A	Average, Current, imaginary part I L	[1]	1
4384	SHORT	RD	A	Average, Current, imaginary part I L	[2]	1
4859	SHORT	RD	Hz	Average, frequency 200 ms, Integer		0,01

* These measured values (address range 3526-4851 and 4858-4861) cannot be read out via the Profinet module of the UMG 96RM-PN. Reading out these measured values via the RS485 interface is supported.

Minimum values, type float

Address	Format	RD/WR	Unit	Note	Index
3436	FLOAT	RD/WR	Hz	Minimum, measured frequency	
3438	FLOAT	RD/WR	-	Minimum, Voltage, zero sequence	
3440	FLOAT	RD/WR	-	Minimum, Voltage, negative sequence	
3442	FLOAT	RD/WR	-	Minimum, Voltage, positive sequence	
3444	FLOAT	RD/WR	V	Minimum, Voltage L-N	[0]
3446	FLOAT	RD/WR	V	Minimum, Voltage L-N	[1]
3448	FLOAT	RD/WR	V	Minimum, Voltage L-N	[2]
3450	FLOAT	RD/WR	V	Minimum, Voltage L-L	[0]
3452	FLOAT	RD/WR	V	Minimum, Voltage L-L	[1]
3454	FLOAT	RD/WR	V	Minimum, Voltage L-L	[2]
3456	FLOAT	RD/WR	-	Minimum, Fund. power factor, CosPhi; ULN IL	[0]
3458	FLOAT	RD/WR	-	Minimum, Fund. power factor, CosPhi; ULN IL	[1]
3460	FLOAT	RD/WR	-	Minimum, Fund. power factor, CosPhi; ULN IL	[2]
3462	FLOAT	RD/WR	-	Minimum, Sum; CosPhisum3=P0sum3/Ssum3	[3]
3464	FLOAT	RD/WR	-	Minimum, Power factor; ULN I L	[0]
3466	FLOAT	RD/WR	-	Minimum, Power factor; ULN I L	[1]
3468	FLOAT	RD/WR	-	Minimum, Power factor; ULN I L	[2]
3470	FLOAT	RD/WR	-	Minimum, Sum; Power factor sum3=Psum3/Ssum3	[3]
3472	FLOAT	RD/WR	%	Minimum, THD U LN	[0]
3474	FLOAT	RD/WR	%	Minimum, THD U LN	[1]
3476	FLOAT	RD/WR	%	Minimum, THD U LN	[2]
3478	FLOAT	RD/WR	%	Minimum, THD U LL	[0]
3480	FLOAT	RD/WR	%	Minimum, THD U LL	[1]
3482	FLOAT	RD/WR	%	Minimum, THD U LL	[2]
3484	FLOAT	RD/WR	V	Minimum, Voltage, real part U LN	[0]
3486	FLOAT	RD/WR	V	Minimum, Voltage, real part U LN	[1]
3488	FLOAT	RD/WR	V	Minimum, Voltage, real part U LN	[2]
3490	FLOAT	RD/WR	V	Minimum, Voltage, imaginary part U LN	[0]
3492	FLOAT	RD/WR	V	Minimum, Voltage, imaginary part U LN	[1]
3494	FLOAT	RD/WR	V	Minimum, Voltage, imaginary part U LN	[2]
4856	FLOAT	RD	Hz	Minimum, frequency 200 ms	

Minimum values, type short (not available for UMG 96RM-PN) *

The measured values in short format do not contain current and voltage transformer ratios.

Address	Format	RD/WR	Unit	Note	Index	Resolution
4814	SHORT	RD/WR	Hz	measured frequency		0,01
4815	SHORT	RD/WR	V	Voltage, zero sequence		0,1
4816	SHORT	RD/WR	V	Voltage, negative sequence		0,1
4817	SHORT	RD/WR	V	Voltage, positive sequence		0,1
4818	SHORT	RD/WR	V	Voltage L-N	[0]	0,1
4819	SHORT	RD/WR	V	Voltage L-N	[1]	0,1
4820	SHORT	RD/WR	V	Voltage L-N	[2]	0,1
4821	SHORT	RD/WR	V	Voltage L-L	[0]	0,1
4822	SHORT	RD/WR	V	Voltage L-L	[1]	0,1
4823	SHORT	RD/WR	V	Voltage L-L	[2]	0,1
4824	SHORT	RD/WR	-	Fund. power factor, CosPhi; ULN IL	[0]	0,01
4825	SHORT	RD/WR	-	Fund. power factor, CosPhi; ULN IL	[1]	0,01
4826	SHORT	RD/WR	-	Fund. power factor, CosPhi; ULN IL	[2]	0,01
4827	SHORT	RD/WR	-	Sum; CosPhi sum3=P0sum3/Ssum3	[3]	0,01
4828	SHORT	RD/WR	-	Power factor; ULN IL	[0]	0,01
4829	SHORT	RD/WR	-	Power factor; ULN IL	[1]	0,01
4830	SHORT	RD/WR	-	Power factor; ULN IL	[2]	0,01
4831	SHORT	RD/WR	-	Sum; Power factor sum3=Psum3/Ssum3	[3]	
4832	SHORT	RD/WR	%	THD U LN	[0]	0,1
4833	SHORT	RD/WR	%	THD U LN	[1]	0,1
4834	SHORT	RD/WR	%	THD U LN	[2]	0,1
4835	SHORT	RD/WR	%	THD U LL	[0]	0,1
4836	SHORT	RD/WR	%	THD U LL	[1]	0,1
4837	SHORT	RD/WR	%	THD U LL	[2]	0,1
4838	SHORT	RD/WR	V	Voltage, real part U LN	[0]	0,1
4839	SHORT	RD/WR	V	Voltage, real part U LN	[1]	0,1
4840	SHORT	RD/WR	V	Voltage, real part U LN	[2]	0,1
4841	SHORT	RD/WR	V	Voltage, imaginary part U LN	[0]	0,1
4842	SHORT	RD/WR	V	Voltage, imaginary part U LN	[1]	0,1
4843	SHORT	RD/WR	V	Voltage, imaginary part U LN	[2]	0,1
4861	SHORT	RD	Hz	Minimum, frequency 200 ms, Integer		0,01

* These measured values (address range 3526-4851 and 4858-4861) cannot be read out via the Profinet module of the UMG 96RM-PN. Reading out these measured values via the RS485 interface is supported.

Maximum values, type float

Address	Format	RD/WR	Unit	Note	Index
2578	FLOAT	RD/WR	Hz	Maximum, measured frequency	
2580	FLOAT	RD/WR	-	Maximum, Voltage, zero sequence	
2582	FLOAT	RD/WR	-	Maximum, Voltage, negative sequence	
2584	FLOAT	RD/WR	-	Maximum, Voltage, positive sequence	
2586	FLOAT	RD/WR	V	Maximum, Voltage L-N	[0]
2588	FLOAT	RD/WR	V	Maximum, Voltage L-N	[1]
2590	FLOAT	RD/WR	V	Maximum, Voltage L-N	[2]
2592	FLOAT	RD/WR	V	Maximum, Voltage L-L	[0]
2594	FLOAT	RD/WR	V	Maximum, Voltage L-L	[1]
2596	FLOAT	RD/WR	V	Maximum, Voltage L-L	[2]
3078	FLOAT	RD/WR	-	Maximum, Fund. power factor, CosPhi; ULN IL	[0]
3080	FLOAT	RD/WR	-	Maximum, Fund. power factor, CosPhi; ULN IL	[1]
3082	FLOAT	RD/WR	-	Maximum, Fund. power factor, CosPhi; ULN IL	[2]
3084	FLOAT	RD/WR	-	Maximum, Sum; CosPhisum3=P0sum3/Ssum3	[3]
3086	FLOAT	RD/WR	-	Maximum, Power factor; ULN IL	[0]
3088	FLOAT	RD/WR	-	Maximum, Power factor; ULN IL	[1]
3090	FLOAT	RD/WR	-	Maximum, Power factor; ULN IL	[2]
3092	FLOAT	RD/WR	-	Maximum, Sum; Power factor sum3=Psum3/Ssum	[3]
3094	FLOAT	RD/WR	%	Maximum, THD, U LN	[0]
3096	FLOAT	RD/WR	%	Maximum, THD, U LN	[1]
3098	FLOAT	RD/WR	%	Maximum, THD, U LN	[2]
3100	FLOAT	RD/WR	%	Maximum, THD, U LL	[0]
3102	FLOAT	RD/WR	%	Maximum, THD, U LL	[1]
3104	FLOAT	RD/WR	%	Maximum, THD, U LL	[2]
3106	FLOAT	RD/WR	V	Maximum, Voltage, real part U LN	[0]
3108	FLOAT	RD/WR	V	Maximum, Voltage, real part U LN	[1]
3110	FLOAT	RD/WR	V	Maximum, Voltage, real part U LN	[2]
3112	FLOAT	RD/WR	V	Maximum, Voltage, imaginary part U LN	[0]
3114	FLOAT	RD/WR	V	Maximum, Voltage, imaginary part U LN	[1]
3116	FLOAT	RD/WR	V	Maximum, Voltage, imaginary part U LN	[2]
3358	FLOAT	RD/WR	A	Maximum, Current I L	[0]
3360	FLOAT	RD/WR	A	Maximum, Current I L	[1]
3362	FLOAT	RD/WR	A	Maximum, Current I L	[2]
3364	FLOAT	RD/WR	A	Maximum, Vector sum; IN=I1+I2+I3	[3]
3366	FLOAT	RD/WR	W	Maximum, Real power P LN	[0]
3368	FLOAT	RD/WR	W	Maximum, Real power P LN	[1]
3370	FLOAT	RD/WR	W	Maximum, Real power P LN	[2]
3372	FLOAT	RD/WR	W	Maximum, Sum; Psum3=P1+P2+P3	[3]
3374	FLOAT	RD/WR	var	Maximum, Fund. reactive power Q LN	[0]
3376	FLOAT	RD/WR	var	Maximum, Fund. reactive power Q LN	[1]
3378	FLOAT	RD/WR	var	Maximum, Fund. reactive power Q LN	[2]
3380	FLOAT	RD/WR	var	Maximum, Sum; Qsum3=Q1+Q2+Q3	[3]
3382	FLOAT	RD/WR	VA	Maximum, Average, Apparent power S LN	[0]
3384	FLOAT	RD/WR	VA	Maximum, Average, Apparent power S LN	[1]
3386	FLOAT	RD/WR	VA	Maximum, Average, Apparent power S LN	[2]
3388	FLOAT	RD/WR	VA	Maximum, Average, Sum; Ssum3=S1+S2+S3	[3]
3390	FLOAT	RD/WR	W	Maximum, Fund. real power P0 LN	[0]
3392	FLOAT	RD/WR	W	Maximum, Fund. real power P0 LN	[1]
3394	FLOAT	RD/WR	W	Maximum, Fund. real power P0 LN	[2]
3396	FLOAT	RD/WR	W	Maximum, Sum; P0sum3=P01+P02+P03	[3]
3398	FLOAT	RD/WR	var	Maximum, Harmonic distortion power D LN	[0]
3400	FLOAT	RD/WR	var	Maximum, Harmonic distortion power D LN	[1]
3402	FLOAT	RD/WR	var	Maximum, Harmonic distortion power D LN	[2]
3404	FLOAT	RD/WR	var	Maximum, Sum; Dsum3=D1+D2+D3	[3]
3406	FLOAT	RD/WR	A	Maximum, THD I	[0]
3408	FLOAT	RD/WR	A	Maximum, THD I	[1]
3410	FLOAT	RD/WR	A	Maximum, THD I	[2]
3412	FLOAT	RD/WR	A	Maximum, TDD I	[0]
3414	FLOAT	RD/WR	A	Maximum, TDD I	[1]
3416	FLOAT	RD/WR	A	Maximum, TDD I	[2]
3418	FLOAT	RD/WR	-	Maximum, Current, zero sequence	
3420	FLOAT	RD/WR	-	Maximum, Current, negative sequence	
3422	FLOAT	RD/WR	-	Maximum, positive sequence	
3424	FLOAT	RD/WR	A	Maximum, real part I L	[0]
3426	FLOAT	RD/WR	A	Maximum, real part I L	[1]
3428	FLOAT	RD/WR	A	Maximum, real part I L	[2]

Address	Format	RD/WR	Unit	Note	Index
3430	FLOAT	RD/WR	A	Maximum, imaginary part I L	[0]
3432	FLOAT	RD/WR	A	Maximum, imaginary part I L	[1]
3434	FLOAT	RD/WR	A	Maximum, imaginary part I L	[2]
4854	FLOAT	RD	Hz	Maximum, frequency 200 ms	

Maximum values, type short (not available for UMG 96RM-PN) *

The measured values in short format do not contain current and voltage transformer ratios.

Address	Format	RD/WR	Unit	Note	Index	Resolution
4385	SHORT	RD/WR	Hz	Maximum, measured frequency		0,01
4386	SHORT	RD/WR	V	Maximum, Voltage, zero sequence		0,1
4387	SHORT	RD/WR	V	Maximum, Voltage, negative sequence		0,1
4388	SHORT	RD/WR	V	Maximum, Voltage, positive sequence		0,1
4389	SHORT	RD/WR	V	Maximum, Voltage L-N	[0]	0,1
4390	SHORT	RD/WR	V	Maximum, Voltage L-N	[1]	0,1
4391	SHORT	RD/WR	V	Maximum, Voltage L-N	[2]	0,1
4392	SHORT	RD/WR	V	Maximum, Voltage L-L	[0]	0,1
4393	SHORT	RD/WR	V	Maximum, Voltage L-L	[1]	0,1
4394	SHORT	RD/WR	V	Maximum, Voltage L-L	[2]	0,1
4635	SHORT	RD/WR	-	Maximum, Fund. power factor, CosPhi; ULN IL	[0]	0,01
4636	SHORT	RD/WR	-	Maximum, Fund. power factor, CosPhi; ULN IL	[1]	0,01
4637	SHORT	RD/WR	-	Maximum, Fund. power factor, CosPhi; ULN IL	[2]	0,01
4638	SHORT	RD/WR	-	Maximum, Sum; CosPhisum3=P0sum3/Ssum3	[3]	0,01
4639	SHORT	RD/WR	-	Maximum, Power factor; ULN IL	[0]	0,01
4640	SHORT	RD/WR	-	Maximum, Power factor; ULN IL	[1]	0,01
4641	SHORT	RD/WR	-	Maximum, Power factor; ULN IL	[2]	0,01
4642	SHORT	RD/WR	-	Maximum, Sum; Power factor sum3=Psum3/Ssum3	[3]	
4643	SHORT	RD/WR	%	Maximum, THD U LN	[0]	0,1
4644	SHORT	RD/WR	%	Maximum, THD U LN	[1]	0,1
4645	SHORT	RD/WR	%	Maximum, THD U LN	[2]	0,1
4646	SHORT	RD/WR	%	Maximum, THD U LL	[0]	0,1
4647	SHORT	RD/WR	%	Maximum, THD U LL	[1]	0,1
4648	SHORT	RD/WR	%	Maximum, THD U LL	[2]	0,1
4649	SHORT	RD/WR	V	Maximum, real part U LN	[0]	0,1
4650	SHORT	RD/WR	V	Maximum, real part U LN	[1]	0,1
4651	SHORT	RD/WR	V	Maximum, real part U LN	[2]	0,1
4652	SHORT	RD/WR	V	Maximum, imaginary part U LN	[0]	0,1
4653	SHORT	RD/WR	V	Maximum, imaginary part U LN	[1]	0,1
4654	SHORT	RD/WR	V	Maximum, imaginary part U LN	[2]	0,1
4775	SHORT	RD/WR	mA	Maximum, Current I L	[0]	1
4776	SHORT	RD/WR	mA	Maximum, Current I L	[1]	1
4777	SHORT	RD/WR	mA	Maximum, Current I L	[2]	1
4778	SHORT	RD/WR	mA	Maximum, Vector sum; IN=I1+I2+I3	[3]	1
4779	SHORT	RD/WR	W	Maximum, Real power P LN	[0]	0,1
4780	SHORT	RD/WR	W	Maximum, Real power P LN	[1]	0,1
4781	SHORT	RD/WR	W	Maximum, Real power P LN	[2]	0,1
4782	SHORT	RD/WR	W	Maximum, Sum; Psum3=P1+P2+P3	[3]	0,1
4783	SHORT	RD/WR	var	Maximum, Fund. reactive power Q LN	[0]	0,1
4784	SHORT	RD/WR	var	Maximum, Fund. reactive power Q LN	[1]	0,1
4785	SHORT	RD/WR	var	Maximum, Fund. reactive power Q LN	[2]	0,1
4786	SHORT	RD/WR	var	Maximum, Sum; Qsum3=Q1+Q2+Q3	[3]	0,1
4787	SHORT	RD/WR	VA	Maximum, Apparent power S LN	[0]	0,1
4788	SHORT	RD/WR	VA	Maximum, Apparent power S LN	[1]	0,1
4789	SHORT	RD/WR	VA	Maximum, Apparent power S LN	[2]	0,1
4790	SHORT	RD/WR	VA	Maximum, Sum; Ssum3=S1+S2+S3	[3]	0,1
4791	SHORT	RD/WR	W	Maximum, Fund. real power P0 LN	[0]	0,1
4792	SHORT	RD/WR	W	Maximum, Fund. real power P0 LN	[1]	0,1
4793	SHORT	RD/WR	W	Maximum, Fund. real power P0 LN	[2]	0,1
4794	SHORT	RD/WR	W	Maximum, Sum; P0sum3=P01+P02+P03	[3]	0,1
4795	SHORT	RD/WR	var	Maximum, Harmonic distortion power D LN	[0]	0,1
4796	SHORT	RD/WR	var	Maximum, Harmonic distortion power D LN	[1]	0,1
4797	SHORT	RD/WR	var	Maximum, Harmonic distortion power D LN	[2]	0,1
4798	SHORT	RD/WR	var	Maximum, Sum; Dsum3=D1+D2+D3	[3]	0,1
4799	SHORT	RD/WR	%	Maximum, THD I	[0]	0,1
4800	SHORT	RD/WR	%	Maximum, THD I	[1]	0,1
4801	SHORT	RD/WR	%	Maximum, THD I	[2]	0,1
4802	SHORT	RD/WR	%	Maximum, TDD I	[0]	0,1
4803	SHORT	RD/WR	%	Maximum, TDD I	[1]	0,1
4804	SHORT	RD/WR	%	Maximum, TDD I	[2]	0,1
4805	SHORT	RD/WR	mA	Maximum, Current, zero sequence		1
4806	SHORT	RD/WR	mA	Maximum, Current, negative sequence		1
4807	SHORT	RD/WR	mA	Maximum, Current, positive sequence		1
4808	SHORT	RD/WR	mA	Maximum, Current, real part IL	[0]	1
4809	SHORT	RD/WR	mA	Maximum, Current, real part IL	[1]	1
4810	SHORT	RD/WR	mA	Maximum, Current, real part IL	[2]	1

Address	Format	RD/WR	Unit	Note	Index	Resolution
4811	SHORT	RD/WR	mA	Maximum, Current, imaginary part I L	[0]	1
4812	SHORT	RD/WR	mA	Maximum, Current, imaginary part I L	[1]	1
4813	SHORT	RD/WR	mA	Maximum, Current, imaginary part I L	[2]	1
4860	SHORT	RD	Hz	Maximum, frequency 200 ms, Integer		0,01

* These measured values (address range 3526-4851 and 4858-4861) cannot be read out via the Profinet module of the UMG 96RM-PN. Reading out these measured values via the RS485 interface is supported.

Maximum values of mean values, type float

Address	Format	RD/WR	Unit	Note	Index
3496	FLOAT	RD/WR	A	Max. values of average val., Current I L	[0]
3498	FLOAT	RD/WR	A	Max. values of average val., Current I L	[1]
3500	FLOAT	RD/WR	A	Max. values of average val., Current I L	[2]
3502	FLOAT	RD/WR	A	Max. values of average val., Vector sum; $IN=I1+I2+I3$	[3]
3504	FLOAT	RD/WR	W	Max. values of average val., Real power P LN	[0]
3506	FLOAT	RD/WR	W	Max. values of average val., Real power P LN	[1]
3508	FLOAT	RD/WR	W	Max. values of average val., Real power P LN	[2]
3510	FLOAT	RD/WR	W	Max. values of average val., Sum; $Psum3=P1+P2+P3$	[3]

Maximum values of mean values, type short (not available for UMG 96RM-PN) *

The measured values in short format do not contain current and voltage transformer ratios.

Address	Format	RD/WR	Unit	Note	Index	Resolution
4844	SHORT	RD/WR	mA	Max. value of average val., Current I L	[0]	1
4845	SHORT	RD/WR	mA	Max. value of average val., Current I L	[1]	1
4846	SHORT	RD/WR	mA	Max. value of average val., Current I L	[2]	1
4847	SHORT	RD/WR	mA	Max. value of average val., Vector sum; $I_N=I_1+I_2+I_3$	[3]	1
4848	SHORT	RD/WR	W	Max. value of average val., Real power P LN	[0]	0,1
4849	SHORT	RD/WR	W	Max. value of average val., Real power P LN	[1]	0,1
4850	SHORT	RD/WR	W	Max. value of average val., Real power P LN	[2]	0,1
4851	SHORT	RD/WR	W	Max. value of average val., Sum; $P_{sum3}=P_1+P_2+P_3$	[3]	0,1

* These measured values (address range 3526-4851 and 4858-4861) cannot be read out via the Profinet module of the UMG 96RM-PN. Reading out these measured values via the RS485 interface is supported.

Energy, type Integer (not available for UMG 96RM-PN) *

The energy values in integer format do not provide any current- and voltage transformer ratios.

Address	Format	RD/WR	Unit	Note	Index
5448	INT	RD	Wh	Real energy, L1, rate	[0]
5450	INT	RD	Wh	Real energy, L1, rate	[1]
5452	INT	RD	Wh	Real energy, L1, rate	[2]
5454	INT	RD	Wh	Real energy, L1, rate	[3]
5456	INT	RD	Wh	Real energy, L1, rate	[4]
5458	INT	RD	Wh	Real energy, L1, rate	[5]
5460	INT	RD	Wh	Real energy, L1, rate	[6]
5462	INT	RD	Wh	Real energy, L1, rate	[7]
5464	INT	RD	Wh	Real energy, L1, obtained, rate	[0]
5466	INT	RD	Wh	Real energy, L1, obtained, rate	[1]
5468	INT	RD	Wh	Real energy, L1, obtained, rate	[2]
5470	INT	RD	Wh	Real energy, L1, obtained, rate	[3]
5472	INT	RD	Wh	Real energy, L1, obtained, rate	[4]
5474	INT	RD	Wh	Real energy, L1, obtained, rate	[5]
5476	INT	RD	Wh	Real energy, L1, obtained, rate	[6]
5478	INT	RD	Wh	Real energy, L1, obtained, rate	[7]
5480	INT	RD	Wh	Real energy, L1, supplied, rate	[0]
5482	INT	RD	Wh	Real energy, L1, supplied, rate	[1]
5484	INT	RD	Wh	Real energy, L1, supplied, rate	[2]
5486	INT	RD	Wh	Real energy, L1, supplied, rate	[3]
5488	INT	RD	Wh	Real energy, L1, supplied, rate	[4]
5490	INT	RD	Wh	Real energy, L1, supplied, rate	[5]
5492	INT	RD	Wh	Real energy, L1, supplied, rate	[6]
5494	INT	RD	Wh	Real energy, L1, supplied, rate	[7]
5496	INT	RD	varh	Reactive energy, L1, rate	[0]
5498	INT	RD	varh	Reactive energy, L1, rate	[1]
5500	INT	RD	varh	Reactive energy, L1, rate	[2]
5502	INT	RD	varh	Reactive energy, L1, rate	[3]
5504	INT	RD	varh	Reactive energy, L1, rate	[4]
5506	INT	RD	varh	Reactive energy, L1, rate	[5]
5508	INT	RD	varh	Reactive energy, L1, rate	[6]
5510	INT	RD	varh	Reactive energy, L1, rate	[7]
5512	INT	RD	varh	Reactive energy, L1, ind., rate	[0]
5514	INT	RD	varh	Reactive energy, L1, ind., rate	[1]
5516	INT	RD	varh	Reactive energy, L1, ind., rate	[2]
5518	INT	RD	varh	Reactive energy, L1, ind., rate	[3]
5520	INT	RD	varh	Reactive energy, L1, ind., rate	[4]
5522	INT	RD	varh	Reactive energy, L1, ind., rate	[5]
5524	INT	RD	varh	Reactive energy, L1, ind., rate	[6]
5526	INT	RD	varh	Reactive energy, L1, ind., rate	[7]
5528	INT	RD	varh	Reactive energy, L1, cap., rate	[0]
5530	INT	RD	varh	Reactive energy, L1, cap., rate	[1]
5532	INT	RD	varh	Reactive energy, L1, cap., rate	[2]
5534	INT	RD	varh	Reactive energy, L1, cap., rate	[3]
5536	INT	RD	varh	Reactive energy, L1, cap., rate	[4]
5538	INT	RD	varh	Reactive energy, L1, cap., rate	[5]
5540	INT	RD	varh	Reactive energy, L1, cap., rate	[6]
5542	INT	RD	varh	Reactive energy, L1, cap., rate	[7]
5544	INT	RD	VAh	Apparent energy, L1, rate	[0]
5546	INT	RD	VAh	Apparent energy, L1, rate	[1]
5548	INT	RD	VAh	Apparent energy, L1, rate	[2]
5550	INT	RD	VAh	Apparent energy, L1, rate	[3]
5552	INT	RD	VAh	Apparent energy, L1, rate	[4]
5554	INT	RD	VAh	Apparent energy, L1, rate	[5]
5556	INT	RD	VAh	Apparent energy, L1, rate	[6]
5558	INT	RD	VAh	Apparent energy, L1, rate	[7]
5560	INT	RD	Wh	Real energy, L2, rate	[0]
5562	INT	RD	Wh	Real energy, L2, rate	[1]
5564	INT	RD	Wh	Real energy, L2, rate	[2]
5566	INT	RD	Wh	Real energy, L2, rate	[3]
5568	INT	RD	Wh	Real energy, L2, rate	[4]
5570	INT	RD	Wh	Real energy, L2, rate	[5]
5572	INT	RD	Wh	Real energy, L2, rate	[6]
5574	INT	RD	Wh	Real energy, L2, rate	[7]
5576	INT	RD	Wh	Real energy, L2, obtained, rate	[0]
5578	INT	RD	Wh	Real energy, L2, obtained, rate	[1]

Address	Format	RD/WR	Unit	Note	Index
5580	INT	RD	Wh	Real energy, L2, obtained, rate	[2]
5582	INT	RD	Wh	Real energy, L2, obtained, rate	[3]
5584	INT	RD	Wh	Real energy, L2, obtained, rate	[4]
5586	INT	RD	Wh	Real energy, L2, obtained, rate	[5]
5588	INT	RD	Wh	Real energy, L2, obtained, rate	[6]
5590	INT	RD	Wh	Real energy, L2, obtained, rate	[7]
5592	INT	RD	Wh	Real energy, L2, supplied, rate	[0]
5594	INT	RD	Wh	Real energy, L2, supplied, rate	[1]
5596	INT	RD	Wh	Real energy, L2, supplied, rate	[2]
5598	INT	RD	Wh	Real energy, L2, supplied, rate	[3]
5600	INT	RD	Wh	Real energy, L2, supplied, rate	[4]
5602	INT	RD	Wh	Real energy, L2, supplied, rate	[5]
5604	INT	RD	Wh	Real energy, L2, supplied, rate	[6]
5606	INT	RD	Wh	Real energy, L2, supplied, rate	[7]
5608	INT	RD	varh	Reactive energy, L2, rate	[0]
5610	INT	RD	varh	Reactive energy, L2, rate	[1]
5612	INT	RD	varh	Reactive energy, L2, rate	[2]
5614	INT	RD	varh	Reactive energy, L2, rate	[3]
5616	INT	RD	varh	Reactive energy, L2, rate	[4]
5618	INT	RD	varh	Reactive energy, L2, rate	[5]
5620	INT	RD	varh	Reactive energy, L2, rate	[6]
5622	INT	RD	varh	Reactive energy, L2, rate	[7]
5624	INT	RD	varh	Reactive energy, L2, ind., rate	[0]
5626	INT	RD	varh	Reactive energy, L2, ind., rate	[1]
5628	INT	RD	varh	Reactive energy, L2, ind., rate	[2]
5630	INT	RD	varh	Reactive energy, L2, ind., rate	[3]
5632	INT	RD	varh	Reactive energy, L2, ind., rate	[4]
5634	INT	RD	varh	Reactive energy, L2, ind., rate	[5]
5636	INT	RD	varh	Reactive energy, L2, ind., rate	[6]
5638	INT	RD	varh	Reactive energy, L2, ind., rate	[7]
5640	INT	RD	varh	Reactive energy, L2, cap., rate	[0]
5642	INT	RD	varh	Reactive energy, L2, cap., rate	[1]
5644	INT	RD	varh	Reactive energy, L2, cap., rate	[2]
5646	INT	RD	varh	Reactive energy, L2, cap., rate	[3]
5648	INT	RD	varh	Reactive energy, L2, cap., rate	[4]
5650	INT	RD	varh	Reactive energy, L2, cap., rate	[5]
5652	INT	RD	varh	Reactive energy, L2, cap., rate	[6]
5654	INT	RD	varh	Reactive energy, L2, cap., rate	[7]
5656	INT	RD	VAh	Apparent energy, L2, rate	[0]
5658	INT	RD	VAh	Apparent energy, L2, rate	[1]
5660	INT	RD	VAh	Apparent energy, L2, rate	[2]
5662	INT	RD	VAh	Apparent energy, L2, rate	[3]
5664	INT	RD	VAh	Apparent energy, L2, rate	[4]
5666	INT	RD	VAh	Apparent energy, L2, rate	[5]
5668	INT	RD	VAh	Apparent energy, L2, rate	[6]
5670	INT	RD	VAh	Apparent energy, L2, rate	[7]
5672	INT	RD	Wh	Real energy, L3, rate	[0]
5674	INT	RD	Wh	Real energy, L3, rate	[1]
5676	INT	RD	Wh	Real energy, L3, rate	[2]
5678	INT	RD	Wh	Real energy, L3, rate	[3]
5680	INT	RD	Wh	Real energy, L3, rate	[4]
5682	INT	RD	Wh	Real energy, L3, rate	[5]
5684	INT	RD	Wh	Real energy, L3, rate	[6]
5686	INT	RD	Wh	Real energy, L3, rate	[7]
5688	INT	RD	Wh	Real energy, L3, obtained, rate	[0]
5690	INT	RD	Wh	Real energy, L3, obtained, rate	[1]
5692	INT	RD	Wh	Real energy, L3, obtained, rate	[2]
5694	INT	RD	Wh	Real energy, L3, obtained, rate	[3]
5696	INT	RD	Wh	Real energy, L3, obtained, rate	[4]
5698	INT	RD	Wh	Real energy, L3, obtained, rate	[5]
5700	INT	RD	Wh	Real energy, L3, obtained, rate	[6]
5702	INT	RD	Wh	Real energy, L3, obtained, rate	[7]
5704	INT	RD	Wh	Real energy, L3, supplied, rate	[0]
5706	INT	RD	Wh	Real energy, L3, supplied, rate	[1]
5708	INT	RD	Wh	Real energy, L3, supplied, rate	[2]
5710	INT	RD	Wh	Real energy, L3, supplied, rate	[3]

Address	Format	RD/WR	Unit	Note	Index
5712	INT	RD	Wh	Real energy, L3, supplied, rate	[4]
5714	INT	RD	Wh	Real energy, L3, supplied, rate	[5]
5716	INT	RD	Wh	Real energy, L3, supplied, rate	[6]
5718	INT	RD	Wh	Real energy, L3, supplied, rate	[7]
5720	INT	RD	varh	Reactive energy, L3, rate	[0]
5722	INT	RD	varh	Reactive energy, L3, rate	[1]
5724	INT	RD	varh	Reactive energy, L3, rate	[2]
5726	INT	RD	varh	Reactive energy, L3, rate	[3]
5728	INT	RD	varh	Reactive energy, L3, rate	[4]
5730	INT	RD	varh	Reactive energy, L3, rate	[5]
5732	INT	RD	varh	Reactive energy, L3, rate	[6]
5734	INT	RD	varh	Reactive energy, L3, rate	[7]
5736	INT	RD	varh	Reactive energy, L3, ind., rate	[0]
5738	INT	RD	varh	Reactive energy, L3, ind., rate	[1]
5740	INT	RD	varh	Reactive energy, L3, ind., rate	[2]
5742	INT	RD	varh	Reactive energy, L3, ind., rate	[3]
5744	INT	RD	varh	Reactive energy, L3, ind., rate	[4]
5746	INT	RD	varh	Reactive energy, L3, ind., rate	[5]
5748	INT	RD	varh	Reactive energy, L3, ind., rate	[6]
5750	INT	RD	varh	Reactive energy, L3, ind., rate	[7]
5752	INT	RD	varh	Reactive energy, L3, cap., rate	[0]
5754	INT	RD	varh	Reactive energy, L3, cap., rate	[1]
5756	INT	RD	varh	Reactive energy, L3, cap., rate	[2]
5758	INT	RD	varh	Reactive energy, L3, cap., rate	[3]
5760	INT	RD	varh	Reactive energy, L3, cap., rate	[4]
5762	INT	RD	varh	Reactive energy, L3, cap., rate	[5]
5764	INT	RD	varh	Reactive energy, L3, cap., rate	[6]
5766	INT	RD	varh	Reactive energy, L3, cap., rate	[7]
5768	INT	RD	VAh	Apparent energy, L3, rate	[0]
5770	INT	RD	VAh	Apparent energy, L3, rate	[1]
5772	INT	RD	VAh	Apparent energy, L3, rate	[2]
5774	INT	RD	VAh	Apparent energy, L3, rate	[3]
5776	INT	RD	VAh	Apparent energy, L3, rate	[4]
5778	INT	RD	VAh	Apparent energy, L3, rate	[5]
5780	INT	RD	VAh	Apparent energy, L3, rate	[6]
5782	INT	RD	VAh	Apparent energy, L3, rate	[7]
5784	INT	RD	Wh	Real energy, sum. L1..L3, rate	[0]
5786	INT	RD	Wh	Real energy, sum. L1..L3, rate	[1]
5788	INT	RD	Wh	Real energy, sum. L1..L3, rate	[2]
5790	INT	RD	Wh	Real energy, sum. L1..L3, rate	[3]
5792	INT	RD	Wh	Real energy, sum. L1..L3, rate	[4]
5794	INT	RD	Wh	Real energy, sum. L1..L3, rate	[5]
5796	INT	RD	Wh	Real energy, sum. L1..L3, rate	[6]
5798	INT	RD	Wh	Real energy, sum. L1..L3, rate	[7]
5800	INT	RD	Wh	Real energy, sum. L1..L3, obtained, rate	[0]
5802	INT	RD	Wh	Real energy, sum. L1..L3, obtained, rate	[1]
5804	INT	RD	Wh	Real energy, sum. L1..L3, obtained, rate	[2]
5806	INT	RD	Wh	Real energy, sum. L1..L3, obtained, rate	[3]
5808	INT	RD	Wh	Real energy, sum. L1..L3, obtained, rate	[4]
5810	INT	RD	Wh	Real energy, sum. L1..L3, obtained, rate	[5]
5812	INT	RD	Wh	Real energy, sum. L1..L3, obtained, rate	[6]
5814	INT	RD	Wh	Real energy, sum. L1..L3, obtained, rate	[7]
5816	INT	RD	Wh	Real energy, sum. L1..L3, supplied, rate	[0]
5818	INT	RD	Wh	Real energy, sum. L1..L3, supplied, rate	[1]
5820	INT	RD	Wh	Real energy, sum. L1..L3, supplied, rate	[2]
5822	INT	RD	Wh	Real energy, sum. L1..L3, supplied, rate	[3]
5824	INT	RD	Wh	Real energy, sum. L1..L3, supplied, rate	[4]
5826	INT	RD	Wh	Real energy, sum. L1..L3, supplied, rate	[5]
5828	INT	RD	Wh	Real energy, sum. L1..L3, supplied, rate	[6]
5830	INT	RD	Wh	Real energy, sum. L1..L3, supplied, rate	[7]
5832	INT	RD	varh	Reactive energy, sum. L1..L3, rate	[0]
5834	INT	RD	varh	Reactive energy, sum. L1..L3, rate	[1]
5836	INT	RD	varh	Reactive energy, sum. L1..L3, rate	[2]
5838	INT	RD	varh	Reactive energy, sum. L1..L3, rate	[3]
5840	INT	RD	varh	Reactive energy, sum. L1..L3, rate	[4]
5842	INT	RD	varh	Reactive energy, sum. L1..L3, rate	[5]

Address	Format	RD/WR	Unit	Note	Index
5844	INT	RD	varh	Reactive energy, sum. L1..L3, rate	[6]
5846	INT	RD	varh	Reactive energy, sum. L1..L3, rate	[7]
5848	INT	RD	varh	Reactive energy, sum. L1..L3, ind., rate	[0]
5850	INT	RD	varh	Reactive energy, sum. L1..L3, ind., rate	[1]
5852	INT	RD	varh	Reactive energy, sum. L1..L3, ind., rate	[2]
5854	INT	RD	varh	Reactive energy, sum. L1..L3, ind., rate	[3]
5856	INT	RD	varh	Reactive energy, sum. L1..L3, ind., rate	[4]
5858	INT	RD	varh	Reactive energy, sum. L1..L3, ind., rate	[5]
5860	INT	RD	varh	Reactive energy, sum. L1..L3, ind., rate	[6]
5862	INT	RD	varh	Reactive energy, sum. L1..L3, ind., rate	[7]
5864	INT	RD	varh	Reactive energy, sum. L1..L3, cap., rate	[0]
5866	INT	RD	varh	Reactive energy, sum. L1..L3, cap., rate	[1]
5868	INT	RD	varh	Reactive energy, sum. L1..L3, cap., rate	[2]
5870	INT	RD	varh	Reactive energy, sum. L1..L3, cap., rate	[3]
5872	INT	RD	varh	Reactive energy, sum. L1..L3, cap., rate	[4]
5874	INT	RD	varh	Reactive energy, sum. L1..L3, cap., rate	[5]
5876	INT	RD	varh	Reactive energy, sum. L1..L3, cap., rate	[6]
5878	INT	RD	varh	Reactive energy, sum. L1..L3, cap., rate	[7]
5880	INT	RD	VAh	Apparent energy, sum. L1..L3, rate	[0]
5882	INT	RD	VAh	Apparent energy, sum. L1..L3, rate	[1]
5884	INT	RD	VAh	Apparent energy, sum. L1..L3, rate	[2]
5886	INT	RD	VAh	Apparent energy, sum. L1..L3, rate	[3]
5888	INT	RD	VAh	Apparent energy, sum. L1..L3, rate	[4]
5890	INT	RD	VAh	Apparent energy, sum. L1..L3, rate	[5]
5892	INT	RD	VAh	Apparent energy, sum. L1..L3, rate	[6]
5894	INT	RD	VAh	Apparent energy, sum. L1..L3, rate	[7]
5896	INT	RD	sec	Operation hours meter	
5898	INT	RD	sec	Total running time, comparator	[0]
5900	INT	RD	sec	Total running time, comparator	[1]
5902	INT	RD	sec	Total running time, comparator	[2]
5904	INT	RD	sec	Total running time, comparator	[3]
5906	INT	RD	sec	Total running time, comparator	[4]
5908	INT	RD	sec	Total running time, comparator	[5]

* These measured values cannot be read out via the Profinet module of the UMG 96RM-PN. Reading out these measured values via the RS485 interface is supported.

Energy, type Float

Address	Format	RD/WR	Unit	Note	Index
5000	FLOAT	RD/WR	Wh	Real energy, L1, rate	[0]
5002	FLOAT	RD/WR	Wh	Real energy, L1, rate	[1]
5004	FLOAT	RD/WR	Wh	Real energy, L1, rate	[2]
5006	FLOAT	RD/WR	Wh	Real energy, L1, rate	[3]
5008	FLOAT	RD/WR	Wh	Real energy, L1, rate	[4]
5010	FLOAT	RD/WR	Wh	Real energy, L1, rate	[5]
5012	FLOAT	RD/WR	Wh	Real energy, L1, rate	[6]
5014	FLOAT	RD/WR	Wh	Real energy, L1, rate	[7]
5016	FLOAT	RD/WR	Wh	Real energy, L1, obtained, rate	[0]
5018	FLOAT	RD/WR	Wh	Real energy, L1, obtained, rate	[1]
5020	FLOAT	RD/WR	Wh	Real energy, L1, obtained, rate	[2]
5022	FLOAT	RD/WR	Wh	Real energy, L1, obtained, rate	[3]
5024	FLOAT	RD/WR	Wh	Real energy, L1, obtained, rate	[4]
5026	FLOAT	RD/WR	Wh	Real energy, L1, obtained, rate	[5]
5028	FLOAT	RD/WR	Wh	Real energy, L1, obtained, rate	[6]
5030	FLOAT	RD/WR	Wh	Real energy, L1, obtained, rate	[7]
5032	FLOAT	RD/WR	Wh	Real energy, L1, supplied, rate	[0]
5034	FLOAT	RD/WR	Wh	Real energy, L1, supplied, rate	[1]
5036	FLOAT	RD/WR	Wh	Real energy, L1, supplied, rate	[2]
5038	FLOAT	RD/WR	Wh	Real energy, L1, supplied, rate	[3]
5040	FLOAT	RD/WR	Wh	Real energy, L1, supplied, rate	[4]
5042	FLOAT	RD/WR	Wh	Real energy, L1, supplied, rate	[5]
5044	FLOAT	RD/WR	Wh	Real energy, L1, supplied, rate	[6]
5046	FLOAT	RD/WR	Wh	Real energy, L1, supplied, rate	[7]
5048	FLOAT	RD/WR	varh	Reactive energy, L1, rate	[0]
5050	FLOAT	RD/WR	varh	Reactive energy, L1, rate	[1]
5052	FLOAT	RD/WR	varh	Reactive energy, L1, rate	[2]
5054	FLOAT	RD/WR	varh	Reactive energy, L1, rate	[3]
5056	FLOAT	RD/WR	varh	Reactive energy, L1, rate	[4]
5058	FLOAT	RD/WR	varh	Reactive energy, L1, rate	[5]
5060	FLOAT	RD/WR	varh	Reactive energy, L1, rate	[6]
5062	FLOAT	RD/WR	varh	Reactive energy, L1, rate	[7]
5064	FLOAT	RD/WR	varh	Reactive energy, L1, ind., rate	[0]
5066	FLOAT	RD/WR	varh	Reactive energy, L1, ind., rate	[1]
5068	FLOAT	RD/WR	varh	Reactive energy, L1, ind., rate	[2]
5070	FLOAT	RD/WR	varh	Reactive energy, L1, ind., rate	[3]
5072	FLOAT	RD/WR	varh	Reactive energy, L1, ind., rate	[4]
5074	FLOAT	RD/WR	varh	Reactive energy, L1, ind., rate	[5]
5076	FLOAT	RD/WR	varh	Reactive energy, L1, ind., rate	[6]
5078	FLOAT	RD/WR	varh	Reactive energy, L1, ind., rate	[7]
5080	FLOAT	RD/WR	varh	Reactive energy, L1, cap., rate	[0]
5082	FLOAT	RD/WR	varh	Reactive energy, L1, cap., rate	[1]
5084	FLOAT	RD/WR	varh	Reactive energy, L1, cap., rate	[2]
5086	FLOAT	RD/WR	varh	Reactive energy, L1, cap., rate	[3]
5088	FLOAT	RD/WR	varh	Reactive energy, L1, cap., rate	[4]
5090	FLOAT	RD/WR	varh	Reactive energy, L1, cap., rate	[5]
5092	FLOAT	RD/WR	varh	Reactive energy, L1, cap., rate	[6]
5094	FLOAT	RD/WR	varh	Reactive energy, L1, cap., rate	[7]
5096	FLOAT	RD/WR	VAh	Apparent energy, L1, rate	[0]
5098	FLOAT	RD/WR	VAh	Apparent energy, L1, rate	[1]
5100	FLOAT	RD/WR	VAh	Apparent energy, L1, rate	[2]
5102	FLOAT	RD/WR	VAh	Apparent energy, L1, rate	[3]
5104	FLOAT	RD/WR	VAh	Apparent energy, L1, rate	[4]
5106	FLOAT	RD/WR	VAh	Apparent energy, L1, rate	[5]
5108	FLOAT	RD/WR	VAh	Apparent energy, L1, rate	[6]
5110	FLOAT	RD/WR	VAh	Apparent energy, L1, rate	[7]
5112	FLOAT	RD/WR	Wh	Real energy, L2, rate	[0]
5114	FLOAT	RD/WR	Wh	Real energy, L2, rate	[1]
5116	FLOAT	RD/WR	Wh	Real energy, L2, rate	[2]
5118	FLOAT	RD/WR	Wh	Real energy, L2, rate	[3]
5120	FLOAT	RD/WR	Wh	Real energy, L2, rate	[4]
5122	FLOAT	RD/WR	Wh	Real energy, L2, rate	[5]
5124	FLOAT	RD/WR	Wh	Real energy, L2, rate	[6]
5126	FLOAT	RD/WR	Wh	Real energy, L2, rate	[7]
5128	FLOAT	RD/WR	Wh	Real energy, L2, obtained, rate	[0]
5130	FLOAT	RD/WR	Wh	Real energy, L2, obtained, rate	[1]

Address	Format	RD/WR	Unit	Note	Index
5132	FLOAT	RD/WR	Wh	Real energy, L2, obtained, rate	[2]
5134	FLOAT	RD/WR	Wh	Real energy, L2, obtained, rate	[3]
5136	FLOAT	RD/WR	Wh	Real energy, L2, obtained, rate	[4]
5138	FLOAT	RD/WR	Wh	Real energy, L2, obtained, rate	[5]
5140	FLOAT	RD/WR	Wh	Real energy, L2, obtained, rate	[6]
5142	FLOAT	RD/WR	Wh	Real energy, L2, obtained, rate	[7]
5144	FLOAT	RD/WR	Wh	Real energy, L2, supplied, rate	[0]
5146	FLOAT	RD/WR	Wh	Real energy, L2, supplied, rate	[1]
5148	FLOAT	RD/WR	Wh	Real energy, L2, supplied, rate	[2]
5150	FLOAT	RD/WR	Wh	Real energy, L2, supplied, rate	[3]
5152	FLOAT	RD/WR	Wh	Real energy, L2, supplied, rate	[4]
5154	FLOAT	RD/WR	Wh	Real energy, L2, supplied, rate	[5]
5156	FLOAT	RD/WR	Wh	Real energy, L2, supplied, rate	[6]
5158	FLOAT	RD/WR	Wh	Real energy, L2, supplied, rate	[7]
5160	FLOAT	RD/WR	varh	Reactive energy, L2, rate	[0]
5162	FLOAT	RD/WR	varh	Reactive energy, L2, rate	[1]
5164	FLOAT	RD/WR	varh	Reactive energy, L2, rate	[2]
5166	FLOAT	RD/WR	varh	Reactive energy, L2, rate	[3]
5168	FLOAT	RD/WR	varh	Reactive energy, L2, rate	[4]
5170	FLOAT	RD/WR	varh	Reactive energy, L2, rate	[5]
5172	FLOAT	RD/WR	varh	Reactive energy, L2, rate	[6]
5174	FLOAT	RD/WR	varh	Reactive energy, L2, rate	[7]
5176	FLOAT	RD/WR	varh	Reactive energy, L2, ind., rate	[0]
5178	FLOAT	RD/WR	varh	Reactive energy, L2, ind., rate	[1]
5180	FLOAT	RD/WR	varh	Reactive energy, L2, ind., rate	[2]
5182	FLOAT	RD/WR	varh	Reactive energy, L2, ind., rate	[3]
5184	FLOAT	RD/WR	varh	Reactive energy, L2, ind., rate	[4]
5186	FLOAT	RD/WR	varh	Reactive energy, L2, ind., rate	[5]
5188	FLOAT	RD/WR	varh	Reactive energy, L2, ind., rate	[6]
5190	FLOAT	RD/WR	varh	Reactive energy, L2, ind., rate	[7]
5192	FLOAT	RD/WR	varh	Reactive energy, L2, cap., rate	[0]
5194	FLOAT	RD/WR	varh	Reactive energy, L2, cap., rate	[1]
5196	FLOAT	RD/WR	varh	Reactive energy, L2, cap., rate	[2]
5198	FLOAT	RD/WR	varh	Reactive energy, L2, cap., rate	[3]
5200	FLOAT	RD/WR	varh	Reactive energy, L2, cap., rate	[4]
5202	FLOAT	RD/WR	varh	Reactive energy, L2, cap., rate	[5]
5204	FLOAT	RD/WR	varh	Reactive energy, L2, cap., rate	[6]
5206	FLOAT	RD/WR	varh	Reactive energy, L2, cap., rate	[7]
5208	FLOAT	RD/WR	VAh	Apparent energy, L2, rate	[0]
5210	FLOAT	RD/WR	VAh	Apparent energy, L2, rate	[1]
5212	FLOAT	RD/WR	VAh	Apparent energy, L2, rate	[2]
5214	FLOAT	RD/WR	VAh	Apparent energy, L2, rate	[3]
5216	FLOAT	RD/WR	VAh	Apparent energy, L2, rate	[4]
5218	FLOAT	RD/WR	VAh	Apparent energy, L2, rate	[5]
5220	FLOAT	RD/WR	VAh	Apparent energy, L2, rate	[6]
5222	FLOAT	RD/WR	VAh	Apparent energy, L2, rate	[7]
5224	FLOAT	RD/WR	Wh	Real energy, L3, rate	[0]
5226	FLOAT	RD/WR	Wh	Real energy, L3, rate	[1]
5228	FLOAT	RD/WR	Wh	Real energy, L3, rate	[2]
5230	FLOAT	RD/WR	Wh	Real energy, L3, rate	[3]
5232	FLOAT	RD/WR	Wh	Real energy, L3, rate	[4]
5234	FLOAT	RD/WR	Wh	Real energy, L3, rate	[5]
5236	FLOAT	RD/WR	Wh	Real energy, L3, rate	[6]
5238	FLOAT	RD/WR	Wh	Real energy, L3, rate	[7]
5240	FLOAT	RD/WR	Wh	Real energy, L3, obtained, rate	[0]
5242	FLOAT	RD/WR	Wh	Real energy, L3, obtained, rate	[1]
5244	FLOAT	RD/WR	Wh	Real energy, L3, obtained, rate	[2]
5246	FLOAT	RD/WR	Wh	Real energy, L3, obtained, rate	[3]
5248	FLOAT	RD/WR	Wh	Real energy, L3, obtained, rate	[4]
5250	FLOAT	RD/WR	Wh	Real energy, L3, obtained, rate	[5]
5252	FLOAT	RD/WR	Wh	Real energy, L3, obtained, rate	[6]
5254	FLOAT	RD/WR	Wh	Real energy, L3, obtained, rate	[7]
5256	FLOAT	RD/WR	Wh	Real energy, L3, supplied, rate	[0]
5258	FLOAT	RD/WR	Wh	Real energy, L3, supplied, rate	[1]
5260	FLOAT	RD/WR	Wh	Real energy, L3, supplied, rate	[2]
5262	FLOAT	RD/WR	Wh	Real energy, L3, supplied, rate	[3]

Address	Format	RD/WR	Unit	Note	Index
5264	FLOAT	RD/WR	Wh	Real energy, L3, supplied, rate	[4]
5266	FLOAT	RD/WR	Wh	Real energy, L3, supplied, rate	[5]
5268	FLOAT	RD/WR	Wh	Real energy, L3, supplied, rate	[6]
5270	FLOAT	RD/WR	Wh	Real energy, L3, supplied, rate	[7]
5272	FLOAT	RD/WR	varh	Reactive energy, L3, rate	[0]
5274	FLOAT	RD/WR	varh	Reactive energy, L3, rate	[1]
5276	FLOAT	RD/WR	varh	Reactive energy, L3, rate	[2]
5278	FLOAT	RD/WR	varh	Reactive energy, L3, rate	[3]
5280	FLOAT	RD/WR	varh	Reactive energy, L3, rate	[4]
5282	FLOAT	RD/WR	varh	Reactive energy, L3, rate	[5]
5284	FLOAT	RD/WR	varh	Reactive energy, L3, rate	[6]
5286	FLOAT	RD/WR	varh	Reactive energy, L3, rate	[7]
5288	FLOAT	RD/WR	varh	Reactive energy, L3, ind., rate	[0]
5290	FLOAT	RD/WR	varh	Reactive energy, L3, ind., rate	[1]
5292	FLOAT	RD/WR	varh	Reactive energy, L3, ind., rate	[2]
5294	FLOAT	RD/WR	varh	Reactive energy, L3, ind., rate	[3]
5296	FLOAT	RD/WR	varh	Reactive energy, L3, ind., rate	[4]
5298	FLOAT	RD/WR	varh	Reactive energy, L3, ind., rate	[5]
5300	FLOAT	RD/WR	varh	Reactive energy, L3, ind., rate	[6]
5302	FLOAT	RD/WR	varh	Reactive energy, L3, ind., rate	[7]
5304	FLOAT	RD/WR	varh	Reactive energy, L3, cap., rate	[0]
5306	FLOAT	RD/WR	varh	Reactive energy, L3, cap., rate	[1]
5308	FLOAT	RD/WR	varh	Reactive energy, L3, cap., rate	[2]
5310	FLOAT	RD/WR	varh	Reactive energy, L3, cap., rate	[3]
5312	FLOAT	RD/WR	varh	Reactive energy, L3, cap., rate	[4]
5314	FLOAT	RD/WR	varh	Reactive energy, L3, cap., rate	[5]
5316	FLOAT	RD/WR	varh	Reactive energy, L3, cap., rate	[6]
5318	FLOAT	RD/WR	varh	Reactive energy, L3, cap., rate	[7]
5320	FLOAT	RD/WR	VAh	Apparent energy, L3, rate	[0]
5322	FLOAT	RD/WR	VAh	Apparent energy, L3, rate	[1]
5324	FLOAT	RD/WR	VAh	Apparent energy, L3, rate	[2]
5326	FLOAT	RD/WR	VAh	Apparent energy, L3, rate	[3]
5328	FLOAT	RD/WR	VAh	Apparent energy, L3, rate	[4]
5330	FLOAT	RD/WR	VAh	Apparent energy, L3, rate	[5]
5332	FLOAT	RD/WR	VAh	Apparent energy, L3, rate	[6]
5334	FLOAT	RD/WR	VAh	Apparent energy, L3, rate	[7]
5336	FLOAT	RD/WR	Wh	Real energy, sum. L1..L3, rate	[0]
5338	FLOAT	RD/WR	Wh	Real energy, sum. L1..L3, rate	[1]
5340	FLOAT	RD/WR	Wh	Real energy, sum. L1..L3, rate	[2]
5342	FLOAT	RD/WR	Wh	Real energy, sum. L1..L3, rate	[3]
5344	FLOAT	RD/WR	Wh	Real energy, sum. L1..L3, rate	[4]
5346	FLOAT	RD/WR	Wh	Real energy, sum. L1..L3, rate	[5]
5348	FLOAT	RD/WR	Wh	Real energy, sum. L1..L3, rate	[6]
5350	FLOAT	RD/WR	Wh	Real energy, sum. L1..L3, rate	[7]
5352	FLOAT	RD/WR	Wh	Real energy, sum. L1..L3, obtained, rate	[0]
5354	FLOAT	RD/WR	Wh	Real energy, sum. L1..L3, obtained, rate	[1]
5356	FLOAT	RD/WR	Wh	Real energy, sum. L1..L3, obtained, rate	[2]
5358	FLOAT	RD/WR	Wh	Real energy, sum. L1..L3, obtained, rate	[3]
5360	FLOAT	RD/WR	Wh	Real energy, sum. L1..L3, obtained, rate	[4]
5362	FLOAT	RD/WR	Wh	Real energy, sum. L1..L3, obtained, rate	[5]
5364	FLOAT	RD/WR	Wh	Real energy, sum. L1..L3, obtained, rate	[6]
5366	FLOAT	RD/WR	Wh	Real energy, sum. L1..L3, obtained, rate	[7]
5368	FLOAT	RD/WR	Wh	Real energy, sum. L1..L3, supplied, rate	[0]
5370	FLOAT	RD/WR	Wh	Real energy, sum. L1..L3, supplied, rate	[1]
5372	FLOAT	RD/WR	Wh	Real energy, sum. L1..L3, supplied, rate	[2]
5374	FLOAT	RD/WR	Wh	Real energy, sum. L1..L3, supplied, rate	[3]
5376	FLOAT	RD/WR	Wh	Real energy, sum. L1..L3, supplied, rate	[4]
5378	FLOAT	RD/WR	Wh	Real energy, sum. L1..L3, supplied, rate	[5]
5380	FLOAT	RD/WR	Wh	Real energy, sum. L1..L3, supplied, rate	[6]
5382	FLOAT	RD/WR	Wh	Real energy, sum. L1..L3, supplied, rate	[7]
5384	FLOAT	RD/WR	varh	Reactive energy, sum. L1..L3, rate	[0]
5386	FLOAT	RD/WR	varh	Reactive energy, sum. L1..L3, rate	[1]
5388	FLOAT	RD/WR	varh	Reactive energy, sum. L1..L3, rate	[2]
5390	FLOAT	RD/WR	varh	Reactive energy, sum. L1..L3, rate	[3]
5392	FLOAT	RD/WR	varh	Reactive energy, sum. L1..L3, rate	[4]
5394	FLOAT	RD/WR	varh	Reactive energy, sum. L1..L3, rate	[5]
5396	FLOAT	RD/WR	varh	Reactive energy, sum. L1..L3, rate	[6]

Address	Format	RD/WR	Unit	Note	Index
5398	FLOAT	RD/WR	varh	Reactive energy, sum. L1..L3, rate	[7]
5400	FLOAT	RD/WR	varh	Reactive energy, sum. L1..L3, ind., rate	[0]
5402	FLOAT	RD/WR	varh	Reactive energy, sum. L1..L3, ind., rate	[1]
5404	FLOAT	RD/WR	varh	Reactive energy, sum. L1..L3, ind., rate	[2]
5406	FLOAT	RD/WR	varh	Reactive energy, sum. L1..L3, ind., rate	[3]
5408	FLOAT	RD/WR	varh	Reactive energy, sum. L1..L3, ind., rate	[4]
5410	FLOAT	RD/WR	varh	Reactive energy, sum. L1..L3, ind., rate	[5]
5412	FLOAT	RD/WR	varh	Reactive energy, sum. L1..L3, ind., rate	[6]
5414	FLOAT	RD/WR	varh	Reactive energy, sum. L1..L3, ind., rate	[7]
5416	FLOAT	RD/WR	varh	Reactive energy, sum. L1..L3, cap., rate	[0]
5418	FLOAT	RD/WR	varh	Reactive energy, sum. L1..L3, cap., rate	[1]
5420	FLOAT	RD/WR	varh	Reactive energy, sum. L1..L3, cap., rate	[2]
5422	FLOAT	RD/WR	varh	Reactive energy, sum. L1..L3, cap., rate	[3]
5424	FLOAT	RD/WR	varh	Reactive energy, sum. L1..L3, cap., rate	[4]
5426	FLOAT	RD/WR	varh	Reactive energy, sum. L1..L3, cap., rate	[5]
5428	FLOAT	RD/WR	varh	Reactive energy, sum. L1..L3, cap., rate	[6]
5430	FLOAT	RD/WR	varh	Reactive energy, sum. L1..L3, cap., rate	[7]
5432	FLOAT	RD/WR	VAh	Apparent energy, sum. L1..L3, rate	[0]
5434	FLOAT	RD/WR	VAh	Apparent energy, sum. L1..L3, rate	[1]
5436	FLOAT	RD/WR	VAh	Apparent energy, sum. L1..L3, rate	[2]
5438	FLOAT	RD/WR	VAh	Apparent energy, sum. L1..L3, rate	[3]
5440	FLOAT	RD/WR	VAh	Apparent energy, sum. L1..L3, rate	[4]
5442	FLOAT	RD/WR	VAh	Apparent energy, sum. L1..L3, rate	[5]
5444	FLOAT	RD/WR	VAh	Apparent energy, sum. L1..L3, rate	[6]
5446	FLOAT	RD/WR	VAh	Apparent energy, sum. L1..L3, rate	[7]

Fourier analysis

Measured values, type float, fourier analysis

Address	Format	RD/WR	Unit	Note	Index
1000	FLOAT	RD	V	Harmonic U L1	[0]
1002	FLOAT	RD	V	Harmonic U L1	[1]
1004	FLOAT	RD	V	Harmonic U L1	[2]
1006	FLOAT	RD	V	Harmonic U L1	[3]
1008	FLOAT	RD	V	Harmonic U L1	[4]
1010	FLOAT	RD	V	Harmonic U L1	[5]
1012	FLOAT	RD	V	Harmonic U L1	[6]
1014	FLOAT	RD	V	Harmonic U L1	[7]
1016	FLOAT	RD	V	Harmonic U L1	[8]
1018	FLOAT	RD	V	Harmonic U L1	[9]
1020	FLOAT	RD	V	Harmonic U L1	[10]
1022	FLOAT	RD	V	Harmonic U L1	[11]
1024	FLOAT	RD	V	Harmonic U L1	[12]
1026	FLOAT	RD	V	Harmonic U L1	[13]
1028	FLOAT	RD	V	Harmonic U L1	[14]
1030	FLOAT	RD	V	Harmonic U L1	[15]
1032	FLOAT	RD	V	Harmonic U L1	[16]
1034	FLOAT	RD	V	Harmonic U L1	[17]
1036	FLOAT	RD	V	Harmonic U L1	[18]
1038	FLOAT	RD	V	Harmonic U L1	[19]
1040	FLOAT	RD	V	Harmonic U L1	[20]
1042	FLOAT	RD	V	Harmonic U L1	[21]
1044	FLOAT	RD	V	Harmonic U L1	[22]
1046	FLOAT	RD	V	Harmonic U L1	[23]
1048	FLOAT	RD	V	Harmonic U L1	[24]
1050	FLOAT	RD	V	Harmonic U L1	[25]
1052	FLOAT	RD	V	Harmonic U L1	[26]
1054	FLOAT	RD	V	Harmonic U L1	[27]
1056	FLOAT	RD	V	Harmonic U L1	[28]
1058	FLOAT	RD	V	Harmonic U L1	[29]
1060	FLOAT	RD	V	Harmonic U L1	[30]
1062	FLOAT	RD	V	Harmonic U L1	[31]
1064	FLOAT	RD	V	Harmonic U L1	[32]
1066	FLOAT	RD	V	Harmonic U L1	[33]
1068	FLOAT	RD	V	Harmonic U L1	[34]
1070	FLOAT	RD	V	Harmonic U L1	[35]
1072	FLOAT	RD	V	Harmonic U L1	[36]
1074	FLOAT	RD	V	Harmonic U L1	[37]
1076	FLOAT	RD	V	Harmonic U L1	[38]
1078	FLOAT	RD	V	Harmonic U L1	[39]
1080	FLOAT	RD	V	Harmonic U L2	[0]
1082	FLOAT	RD	V	Harmonic U L2	[1]
1084	FLOAT	RD	V	Harmonic U L2	[2]
1086	FLOAT	RD	V	Harmonic U L2	[3]
1088	FLOAT	RD	V	Harmonic U L2	[4]
1090	FLOAT	RD	V	Harmonic U L2	[5]
1092	FLOAT	RD	V	Harmonic U L2	[6]
1094	FLOAT	RD	V	Harmonic U L2	[7]
1096	FLOAT	RD	V	Harmonic U L2	[8]
1098	FLOAT	RD	V	Harmonic U L2	[9]
1100	FLOAT	RD	V	Harmonic U L2	[10]
1102	FLOAT	RD	V	Harmonic U L2	[11]
1104	FLOAT	RD	V	Harmonic U L2	[12]
1106	FLOAT	RD	V	Harmonic U L2	[13]
1108	FLOAT	RD	V	Harmonic U L2	[14]
1110	FLOAT	RD	V	Harmonic U L2	[15]
1112	FLOAT	RD	V	Harmonic U L2	[16]
1114	FLOAT	RD	V	Harmonic U L2	[17]
1116	FLOAT	RD	V	Harmonic U L2	[18]
1118	FLOAT	RD	V	Harmonic U L2	[19]
1120	FLOAT	RD	V	Harmonic U L2	[20]
1122	FLOAT	RD	V	Harmonic U L2	[21]
1124	FLOAT	RD	V	Harmonic U L2	[22]
1126	FLOAT	RD	V	Harmonic U L2	[23]
1128	FLOAT	RD	V	Harmonic U L2	[24]
1130	FLOAT	RD	V	Harmonic U L2	[25]

Address	Format	RD/WR	Unit	Note	Index
1132	FLOAT	RD	V	Harmonic U L2	[26]
1134	FLOAT	RD	V	Harmonic U L2	[27]
1136	FLOAT	RD	V	Harmonic U L2	[28]
1138	FLOAT	RD	V	Harmonic U L2	[29]
1140	FLOAT	RD	V	Harmonic U L2	[30]
1142	FLOAT	RD	V	Harmonic U L2	[31]
1144	FLOAT	RD	V	Harmonic U L2	[32]
1146	FLOAT	RD	V	Harmonic U L2	[33]
1148	FLOAT	RD	V	Harmonic U L2	[34]
1150	FLOAT	RD	V	Harmonic U L2	[35]
1152	FLOAT	RD	V	Harmonic U L2	[36]
1154	FLOAT	RD	V	Harmonic U L2	[37]
1156	FLOAT	RD	V	Harmonic U L2	[38]
1158	FLOAT	RD	V	Harmonic U L2	[39]
1160	FLOAT	RD	V	Harmonic U L3	[0]
1162	FLOAT	RD	V	Harmonic U L3	[1]
1164	FLOAT	RD	V	Harmonic U L3	[2]
1166	FLOAT	RD	V	Harmonic U L3	[3]
1168	FLOAT	RD	V	Harmonic U L3	[4]
1170	FLOAT	RD	V	Harmonic U L3	[5]
1172	FLOAT	RD	V	Harmonic U L3	[6]
1174	FLOAT	RD	V	Harmonic U L3	[7]
1176	FLOAT	RD	V	Harmonic U L3	[8]
1178	FLOAT	RD	V	Harmonic U L3	[9]
1180	FLOAT	RD	V	Harmonic U L3	[10]
1182	FLOAT	RD	V	Harmonic U L3	[11]
1184	FLOAT	RD	V	Harmonic U L3	[12]
1186	FLOAT	RD	V	Harmonic U L3	[13]
1188	FLOAT	RD	V	Harmonic U L3	[14]
1190	FLOAT	RD	V	Harmonic U L3	[15]
1192	FLOAT	RD	V	Harmonic U L3	[16]
1194	FLOAT	RD	V	Harmonic U L3	[17]
1196	FLOAT	RD	V	Harmonic U L3	[18]
1198	FLOAT	RD	V	Harmonic U L3	[19]
1200	FLOAT	RD	V	Harmonic U L3	[20]
1202	FLOAT	RD	V	Harmonic U L3	[21]
1204	FLOAT	RD	V	Harmonic U L3	[22]
1206	FLOAT	RD	V	Harmonic U L3	[23]
1208	FLOAT	RD	V	Harmonic U L3	[24]
1210	FLOAT	RD	V	Harmonic U L3	[25]
1212	FLOAT	RD	V	Harmonic U L3	[26]
1214	FLOAT	RD	V	Harmonic U L3	[27]
1216	FLOAT	RD	V	Harmonic U L3	[28]
1218	FLOAT	RD	V	Harmonic U L3	[29]
1220	FLOAT	RD	V	Harmonic U L3	[30]
1222	FLOAT	RD	V	Harmonic U L3	[31]
1224	FLOAT	RD	V	Harmonic U L3	[32]
1226	FLOAT	RD	V	Harmonic U L3	[33]
1228	FLOAT	RD	V	Harmonic U L3	[34]
1230	FLOAT	RD	V	Harmonic U L3	[35]
1232	FLOAT	RD	V	Harmonic U L3	[36]
1234	FLOAT	RD	V	Harmonic U L3	[37]
1236	FLOAT	RD	V	Harmonic U L3	[38]
1238	FLOAT	RD	V	Harmonic U L3	[39]
1240	FLOAT	RD	V	Harmonic U L1-L2	[0]
1242	FLOAT	RD	V	Harmonic U L1-L2	[1]
1244	FLOAT	RD	V	Harmonic U L1-L2	[2]
1246	FLOAT	RD	V	Harmonic U L1-L2	[3]
1248	FLOAT	RD	V	Harmonic U L1-L2	[4]
1250	FLOAT	RD	V	Harmonic U L1-L2	[5]
1252	FLOAT	RD	V	Harmonic U L1-L2	[6]
1254	FLOAT	RD	V	Harmonic U L1-L2	[7]
1256	FLOAT	RD	V	Harmonic U L1-L2	[8]
1258	FLOAT	RD	V	Harmonic U L1-L2	[9]
1260	FLOAT	RD	V	Harmonic U L1-L2	[10]
1262	FLOAT	RD	V	Harmonic U L1-L2	[11]

Address	Format	RD/WR	Unit	Note	Index
1264	FLOAT	RD	V	Harmonic U L1-L2	[12]
1266	FLOAT	RD	V	Harmonic U L1-L2	[13]
1268	FLOAT	RD	V	Harmonic U L1-L2	[14]
1270	FLOAT	RD	V	Harmonic U L1-L2	[15]
1272	FLOAT	RD	V	Harmonic U L1-L2	[16]
1274	FLOAT	RD	V	Harmonic U L1-L2	[17]
1276	FLOAT	RD	V	Harmonic U L1-L2	[18]
1278	FLOAT	RD	V	Harmonic U L1-L2	[19]
1280	FLOAT	RD	V	Harmonic U L1-L2	[20]
1282	FLOAT	RD	V	Harmonic U L1-L2	[21]
1284	FLOAT	RD	V	Harmonic U L1-L2	[22]
1286	FLOAT	RD	V	Harmonic U L1-L2	[23]
1288	FLOAT	RD	V	Harmonic U L1-L2	[24]
1290	FLOAT	RD	V	Harmonic U L1-L2	[25]
1292	FLOAT	RD	V	Harmonic U L1-L2	[26]
1294	FLOAT	RD	V	Harmonic U L1-L2	[27]
1296	FLOAT	RD	V	Harmonic U L1-L2	[28]
1298	FLOAT	RD	V	Harmonic U L1-L2	[29]
1300	FLOAT	RD	V	Harmonic U L1-L2	[30]
1302	FLOAT	RD	V	Harmonic U L1-L2	[31]
1304	FLOAT	RD	V	Harmonic U L1-L2	[32]
1306	FLOAT	RD	V	Harmonic U L1-L2	[33]
1308	FLOAT	RD	V	Harmonic U L1-L2	[34]
1310	FLOAT	RD	V	Harmonic U L1-L2	[35]
1312	FLOAT	RD	V	Harmonic U L1-L2	[36]
1314	FLOAT	RD	V	Harmonic U L1-L2	[37]
1316	FLOAT	RD	V	Harmonic U L1-L2	[38]
1318	FLOAT	RD	V	Harmonic U L1-L2	[39]
1320	FLOAT	RD	V	Harmonic U L2-L3	[0]
1322	FLOAT	RD	V	Harmonic U L2-L3	[1]
1324	FLOAT	RD	V	Harmonic U L2-L3	[2]
1326	FLOAT	RD	V	Harmonic U L2-L3	[3]
1328	FLOAT	RD	V	Harmonic U L2-L3	[4]
1330	FLOAT	RD	V	Harmonic U L2-L3	[5]
1332	FLOAT	RD	V	Harmonic U L2-L3	[6]
1334	FLOAT	RD	V	Harmonic U L2-L3	[7]
1336	FLOAT	RD	V	Harmonic U L2-L3	[8]
1338	FLOAT	RD	V	Harmonic U L2-L3	[9]
1340	FLOAT	RD	V	Harmonic U L2-L3	[10]
1342	FLOAT	RD	V	Harmonic U L2-L3	[11]
1344	FLOAT	RD	V	Harmonic U L2-L3	[12]
1346	FLOAT	RD	V	Harmonic U L2-L3	[13]
1348	FLOAT	RD	V	Harmonic U L2-L3	[14]
1350	FLOAT	RD	V	Harmonic U L2-L3	[15]
1352	FLOAT	RD	V	Harmonic U L2-L3	[16]
1354	FLOAT	RD	V	Harmonic U L2-L3	[17]
1356	FLOAT	RD	V	Harmonic U L2-L3	[18]
1358	FLOAT	RD	V	Harmonic U L2-L3	[19]
1360	FLOAT	RD	V	Harmonic U L2-L3	[20]
1362	FLOAT	RD	V	Harmonic U L2-L3	[21]
1364	FLOAT	RD	V	Harmonic U L2-L3	[22]
1366	FLOAT	RD	V	Harmonic U L2-L3	[23]
1368	FLOAT	RD	V	Harmonic U L2-L3	[24]
1370	FLOAT	RD	V	Harmonic U L2-L3	[25]
1372	FLOAT	RD	V	Harmonic U L2-L3	[26]
1374	FLOAT	RD	V	Harmonic U L2-L3	[27]
1376	FLOAT	RD	V	Harmonic U L2-L3	[28]
1378	FLOAT	RD	V	Harmonic U L2-L3	[29]
1380	FLOAT	RD	V	Harmonic U L2-L3	[30]
1382	FLOAT	RD	V	Harmonic U L2-L3	[31]
1384	FLOAT	RD	V	Harmonic U L2-L3	[32]
1386	FLOAT	RD	V	Harmonic U L2-L3	[33]
1388	FLOAT	RD	V	Harmonic U L2-L3	[34]
1390	FLOAT	RD	V	Harmonic U L2-L3	[35]
1392	FLOAT	RD	V	Harmonic U L2-L3	[36]
1394	FLOAT	RD	V	Harmonic U L2-L3	[37]

Address	Format	RD/WR	Unit	Note	Index
1396	FLOAT	RD	V	Harmonic U L2-L3	[38]
1398	FLOAT	RD	V	Harmonic U L2-L3	[39]
1400	FLOAT	RD	V	Harmonic U L3-L1	[0]
1402	FLOAT	RD	V	Harmonic U L3-L1	[1]
1404	FLOAT	RD	V	Harmonic U L3-L1	[2]
1406	FLOAT	RD	V	Harmonic U L3-L1	[3]
1408	FLOAT	RD	V	Harmonic U L3-L1	[4]
1410	FLOAT	RD	V	Harmonic U L3-L1	[5]
1412	FLOAT	RD	V	Harmonic U L3-L1	[6]
1414	FLOAT	RD	V	Harmonic U L3-L1	[7]
1416	FLOAT	RD	V	Harmonic U L3-L1	[8]
1418	FLOAT	RD	V	Harmonic U L3-L1	[9]
1420	FLOAT	RD	V	Harmonic U L3-L1	[10]
1422	FLOAT	RD	V	Harmonic U L3-L1	[11]
1424	FLOAT	RD	V	Harmonic U L3-L1	[12]
1426	FLOAT	RD	V	Harmonic U L3-L1	[13]
1428	FLOAT	RD	V	Harmonic U L3-L1	[14]
1430	FLOAT	RD	V	Harmonic U L3-L1	[15]
1432	FLOAT	RD	V	Harmonic U L3-L1	[16]
1434	FLOAT	RD	V	Harmonic U L3-L1	[17]
1436	FLOAT	RD	V	Harmonic U L3-L1	[18]
1438	FLOAT	RD	V	Harmonic U L3-L1	[19]
1440	FLOAT	RD	V	Harmonic U L3-L1	[20]
1442	FLOAT	RD	V	Harmonic U L3-L1	[21]
1444	FLOAT	RD	V	Harmonic U L3-L1	[22]
1446	FLOAT	RD	V	Harmonic U L3-L1	[23]
1448	FLOAT	RD	V	Harmonic U L3-L1	[24]
1450	FLOAT	RD	V	Harmonic U L3-L1	[25]
1452	FLOAT	RD	V	Harmonic U L3-L1	[26]
1454	FLOAT	RD	V	Harmonic U L3-L1	[27]
1456	FLOAT	RD	V	Harmonic U L3-L1	[28]
1458	FLOAT	RD	V	Harmonic U L3-L1	[29]
1460	FLOAT	RD	V	Harmonic U L3-L1	[30]
1462	FLOAT	RD	V	Harmonic U L3-L1	[31]
1464	FLOAT	RD	V	Harmonic U L3-L1	[32]
1466	FLOAT	RD	V	Harmonic U L3-L1	[33]
1468	FLOAT	RD	V	Harmonic U L3-L1	[34]
1470	FLOAT	RD	V	Harmonic U L3-L1	[35]
1472	FLOAT	RD	V	Harmonic U L3-L1	[36]
1474	FLOAT	RD	V	Harmonic U L3-L1	[37]
1476	FLOAT	RD	V	Harmonic U L3-L1	[38]
1478	FLOAT	RD	V	Harmonic U L3-L1	[39]
1480	FLOAT	RD	A	Harmonic I L1	[0]
1482	FLOAT	RD	A	Harmonic I L1	[1]
1484	FLOAT	RD	A	Harmonic I L1	[2]
1486	FLOAT	RD	A	Harmonic I L1	[3]
1488	FLOAT	RD	A	Harmonic I L1	[4]
1490	FLOAT	RD	A	Harmonic I L1	[5]
1492	FLOAT	RD	A	Harmonic I L1	[6]
1494	FLOAT	RD	A	Harmonic I L1	[7]
1496	FLOAT	RD	A	Harmonic I L1	[8]
1498	FLOAT	RD	A	Harmonic I L1	[9]
1500	FLOAT	RD	A	Harmonic I L1	[10]
1502	FLOAT	RD	A	Harmonic I L1	[11]
1504	FLOAT	RD	A	Harmonic I L1	[12]
1506	FLOAT	RD	A	Harmonic I L1	[13]
1508	FLOAT	RD	A	Harmonic I L1	[14]
1510	FLOAT	RD	A	Harmonic I L1	[15]
1512	FLOAT	RD	A	Harmonic I L1	[16]
1514	FLOAT	RD	A	Harmonic I L1	[17]
1516	FLOAT	RD	A	Harmonic I L1	[18]
1518	FLOAT	RD	A	Harmonic I L1	[19]
1520	FLOAT	RD	A	Harmonic I L1	[20]
1522	FLOAT	RD	A	Harmonic I L1	[21]
1524	FLOAT	RD	A	Harmonic I L1	[22]
1526	FLOAT	RD	A	Harmonic I L1	[23]

Address	Format	RD/WR	Unit	Note	Index
1528	FLOAT	RD	A	Harmonic I L1	[24]
1530	FLOAT	RD	A	Harmonic I L1	[25]
1532	FLOAT	RD	A	Harmonic I L1	[26]
1534	FLOAT	RD	A	Harmonic I L1	[27]
1536	FLOAT	RD	A	Harmonic I L1	[28]
1538	FLOAT	RD	A	Harmonic I L1	[29]
1540	FLOAT	RD	A	Harmonic I L1	[30]
1542	FLOAT	RD	A	Harmonic I L1	[31]
1544	FLOAT	RD	A	Harmonic I L1	[32]
1546	FLOAT	RD	A	Harmonic I L1	[33]
1548	FLOAT	RD	A	Harmonic I L1	[34]
1550	FLOAT	RD	A	Harmonic I L1	[35]
1552	FLOAT	RD	A	Harmonic I L1	[36]
1554	FLOAT	RD	A	Harmonic I L1	[37]
1556	FLOAT	RD	A	Harmonic I L1	[38]
1558	FLOAT	RD	A	Harmonic I L1	[39]
1560	FLOAT	RD	A	Harmonic I L2	[0]
1562	FLOAT	RD	A	Harmonic I L2	[1]
1564	FLOAT	RD	A	Harmonic I L2	[2]
1566	FLOAT	RD	A	Harmonic I L2	[3]
1568	FLOAT	RD	A	Harmonic I L2	[4]
1570	FLOAT	RD	A	Harmonic I L2	[5]
1572	FLOAT	RD	A	Harmonic I L2	[6]
1574	FLOAT	RD	A	Harmonic I L2	[7]
1576	FLOAT	RD	A	Harmonic I L2	[8]
1578	FLOAT	RD	A	Harmonic I L2	[9]
1580	FLOAT	RD	A	Harmonic I L2	[10]
1582	FLOAT	RD	A	Harmonic I L2	[11]
1584	FLOAT	RD	A	Harmonic I L2	[12]
1586	FLOAT	RD	A	Harmonic I L2	[13]
1588	FLOAT	RD	A	Harmonic I L2	[14]
1590	FLOAT	RD	A	Harmonic I L2	[15]
1592	FLOAT	RD	A	Harmonic I L2	[16]
1594	FLOAT	RD	A	Harmonic I L2	[17]
1596	FLOAT	RD	A	Harmonic I L2	[18]
1598	FLOAT	RD	A	Harmonic I L2	[19]
1600	FLOAT	RD	A	Harmonic I L2	[20]
1602	FLOAT	RD	A	Harmonic I L2	[21]
1604	FLOAT	RD	A	Harmonic I L2	[22]
1606	FLOAT	RD	A	Harmonic I L2	[23]
1608	FLOAT	RD	A	Harmonic I L2	[24]
1610	FLOAT	RD	A	Harmonic I L2	[25]
1612	FLOAT	RD	A	Harmonic I L2	[26]
1614	FLOAT	RD	A	Harmonic I L2	[27]
1616	FLOAT	RD	A	Harmonic I L2	[28]
1618	FLOAT	RD	A	Harmonic I L2	[29]
1620	FLOAT	RD	A	Harmonic I L2	[30]
1622	FLOAT	RD	A	Harmonic I L2	[31]
1624	FLOAT	RD	A	Harmonic I L2	[32]
1626	FLOAT	RD	A	Harmonic I L2	[33]
1628	FLOAT	RD	A	Harmonic I L2	[34]
1630	FLOAT	RD	A	Harmonic I L2	[35]
1632	FLOAT	RD	A	Harmonic I L2	[36]
1634	FLOAT	RD	A	Harmonic I L2	[37]
1636	FLOAT	RD	A	Harmonic I L2	[38]
1638	FLOAT	RD	A	Harmonic I L2	[39]
1640	FLOAT	RD	A	Harmonic I L3	[0]
1642	FLOAT	RD	A	Harmonic I L3	[1]
1644	FLOAT	RD	A	Harmonic I L3	[2]
1646	FLOAT	RD	A	Harmonic I L3	[3]
1648	FLOAT	RD	A	Harmonic I L3	[4]
1650	FLOAT	RD	A	Harmonic I L3	[5]
1652	FLOAT	RD	A	Harmonic I L3	[6]
1654	FLOAT	RD	A	Harmonic I L3	[7]
1656	FLOAT	RD	A	Harmonic I L3	[8]
1658	FLOAT	RD	A	Harmonic I L3	[9]

Address	Format	RD/WR	Unit	Note	Index
1660	FLOAT	RD	A	Harmonic I L3	[10]
1662	FLOAT	RD	A	Harmonic I L3	[11]
1664	FLOAT	RD	A	Harmonic I L3	[12]
1666	FLOAT	RD	A	Harmonic I L3	[13]
1668	FLOAT	RD	A	Harmonic I L3	[14]
1670	FLOAT	RD	A	Harmonic I L3	[15]
1672	FLOAT	RD	A	Harmonic I L3	[16]
1674	FLOAT	RD	A	Harmonic I L3	[17]
1676	FLOAT	RD	A	Harmonic I L3	[18]
1678	FLOAT	RD	A	Harmonic I L3	[19]
1680	FLOAT	RD	A	Harmonic I L3	[20]
1682	FLOAT	RD	A	Harmonic I L3	[21]
1684	FLOAT	RD	A	Harmonic I L3	[22]
1686	FLOAT	RD	A	Harmonic I L3	[23]
1688	FLOAT	RD	A	Harmonic I L3	[24]
1690	FLOAT	RD	A	Harmonic I L3	[25]
1692	FLOAT	RD	A	Harmonic I L3	[26]
1694	FLOAT	RD	A	Harmonic I L3	[27]
1696	FLOAT	RD	A	Harmonic I L3	[28]
1698	FLOAT	RD	A	Harmonic I L3	[29]
1700	FLOAT	RD	A	Harmonic I L3	[30]
1702	FLOAT	RD	A	Harmonic I L3	[31]
1704	FLOAT	RD	A	Harmonic I L3	[32]
1706	FLOAT	RD	A	Harmonic I L3	[33]
1708	FLOAT	RD	A	Harmonic I L3	[34]
1710	FLOAT	RD	A	Harmonic I L3	[35]
1712	FLOAT	RD	A	Harmonic I L3	[36]
1714	FLOAT	RD	A	Harmonic I L3	[37]
1716	FLOAT	RD	A	Harmonic I L3	[38]
1718	FLOAT	RD	A	Harmonic I L3	[39]

Measured values, type short, fourier analysis

The measured values in short format do not contain current and voltage transformer ratios.

Address	Format	RD/WR	Unit	Note	Index	Resolution
3536	SHORT	RD	V	Harmonic U L1	[0]	0,1
3537	SHORT	RD	V	Harmonic U L1	[1]	0,1
3538	SHORT	RD	V	Harmonic U L1	[2]	0,1
3539	SHORT	RD	V	Harmonic U L1	[3]	0,1
3540	SHORT	RD	V	Harmonic U L1	[4]	0,1
3541	SHORT	RD	V	Harmonic U L1	[5]	0,1
3542	SHORT	RD	V	Harmonic U L1	[6]	0,1
3543	SHORT	RD	V	Harmonic U L1	[7]	0,1
3544	SHORT	RD	V	Harmonic U L1	[8]	0,1
3545	SHORT	RD	V	Harmonic U L1	[9]	0,1
3546	SHORT	RD	V	Harmonic U L1	[10]	0,1
3547	SHORT	RD	V	Harmonic U L1	[11]	0,1
3548	SHORT	RD	V	Harmonic U L1	[12]	0,1
3549	SHORT	RD	V	Harmonic U L1	[13]	0,1
3550	SHORT	RD	V	Harmonic U L1	[14]	0,1
3551	SHORT	RD	V	Harmonic U L1	[15]	0,1
3552	SHORT	RD	V	Harmonic U L1	[16]	0,1
3553	SHORT	RD	V	Harmonic U L1	[17]	0,1
3554	SHORT	RD	V	Harmonic U L1	[18]	0,1
3555	SHORT	RD	V	Harmonic U L1	[19]	0,1
3556	SHORT	RD	V	Harmonic U L1	[20]	0,1
3557	SHORT	RD	V	Harmonic U L1	[21]	0,1
3558	SHORT	RD	V	Harmonic U L1	[22]	0,1
3559	SHORT	RD	V	Harmonic U L1	[23]	0,1
3560	SHORT	RD	V	Harmonic U L1	[24]	0,1
3561	SHORT	RD	V	Harmonic U L1	[25]	0,1
3562	SHORT	RD	V	Harmonic U L1	[26]	0,1
3563	SHORT	RD	V	Harmonic U L1	[27]	0,1
3564	SHORT	RD	V	Harmonic U L1	[28]	0,1
3565	SHORT	RD	V	Harmonic U L1	[29]	0,1
3566	SHORT	RD	V	Harmonic U L1	[30]	0,1
3567	SHORT	RD	V	Harmonic U L1	[31]	0,1
3568	SHORT	RD	V	Harmonic U L1	[32]	0,1
3569	SHORT	RD	V	Harmonic U L1	[33]	0,1
3570	SHORT	RD	V	Harmonic U L1	[34]	0,1
3571	SHORT	RD	V	Harmonic U L1	[35]	0,1
3572	SHORT	RD	V	Harmonic U L1	[36]	0,1
3573	SHORT	RD	V	Harmonic U L1	[37]	0,1
3574	SHORT	RD	V	Harmonic U L1	[38]	0,1
3575	SHORT	RD	V	Harmonic U L1	[39]	0,1
3576	SHORT	RD	V	Harmonic U L2	[0]	0,1
3577	SHORT	RD	V	Harmonic U L2	[1]	0,1
3578	SHORT	RD	V	Harmonic U L2	[2]	0,1
3579	SHORT	RD	V	Harmonic U L2	[3]	0,1
3580	SHORT	RD	V	Harmonic U L2	[4]	0,1
3581	SHORT	RD	V	Harmonic U L2	[5]	0,1
3582	SHORT	RD	V	Harmonic U L2	[6]	0,1
3583	SHORT	RD	V	Harmonic U L2	[7]	0,1
3584	SHORT	RD	V	Harmonic U L2	[8]	0,1
3585	SHORT	RD	V	Harmonic U L2	[9]	0,1
3586	SHORT	RD	V	Harmonic U L2	[10]	0,1
3587	SHORT	RD	V	Harmonic U L2	[11]	0,1
3588	SHORT	RD	V	Harmonic U L2	[12]	0,1
3589	SHORT	RD	V	Harmonic U L2	[13]	0,1
3590	SHORT	RD	V	Harmonic U L2	[14]	0,1
3591	SHORT	RD	V	Harmonic U L2	[15]	0,1
3592	SHORT	RD	V	Harmonic U L2	[16]	0,1
3593	SHORT	RD	V	Harmonic U L2	[17]	0,1
3594	SHORT	RD	V	Harmonic U L2	[18]	0,1
3595	SHORT	RD	V	Harmonic U L2	[19]	0,1
3596	SHORT	RD	V	Harmonic U L2	[20]	0,1
3597	SHORT	RD	V	Harmonic U L2	[21]	0,1
3598	SHORT	RD	V	Harmonic U L2	[22]	0,1
3599	SHORT	RD	V	Harmonic U L2	[23]	0,1
3600	SHORT	RD	V	Harmonic U L2	[24]	0,1
3601	SHORT	RD	V	Harmonic U L2	[25]	0,1

Address	Format	RD/WR	Unit	Note	Index	Resolution
3602	SHORT	RD	V	Harmonic U L2	[26]	0,1
3603	SHORT	RD	V	Harmonic U L2	[27]	0,1
3604	SHORT	RD	V	Harmonic U L2	[28]	0,1
3605	SHORT	RD	V	Harmonic U L2	[29]	0,1
3606	SHORT	RD	V	Harmonic U L2	[30]	0,1
3607	SHORT	RD	V	Harmonic U L2	[31]	0,1
3608	SHORT	RD	V	Harmonic U L2	[32]	0,1
3609	SHORT	RD	V	Harmonic U L2	[33]	0,1
3610	SHORT	RD	V	Harmonic U L2	[34]	0,1
3611	SHORT	RD	V	Harmonic U L2	[35]	0,1
3612	SHORT	RD	V	Harmonic U L2	[36]	0,1
3613	SHORT	RD	V	Harmonic U L2	[37]	0,1
3614	SHORT	RD	V	Harmonic U L2	[38]	0,1
3615	SHORT	RD	V	Harmonic U L2	[39]	0,1
3616	SHORT	RD	V	Harmonic U L3	[0]	0,1
3617	SHORT	RD	V	Harmonic U L3	[1]	0,1
3618	SHORT	RD	V	Harmonic U L3	[2]	0,1
3619	SHORT	RD	V	Harmonic U L3	[3]	0,1
3620	SHORT	RD	V	Harmonic U L3	[4]	0,1
3621	SHORT	RD	V	Harmonic U L3	[5]	0,1
3622	SHORT	RD	V	Harmonic U L3	[6]	0,1
3623	SHORT	RD	V	Harmonic U L3	[7]	0,1
3624	SHORT	RD	V	Harmonic U L3	[8]	0,1
3625	SHORT	RD	V	Harmonic U L3	[9]	0,1
3626	SHORT	RD	V	Harmonic U L3	[10]	0,1
3627	SHORT	RD	V	Harmonic U L3	[11]	0,1
3628	SHORT	RD	V	Harmonic U L3	[12]	0,1
3629	SHORT	RD	V	Harmonic U L3	[13]	0,1
3630	SHORT	RD	V	Harmonic U L3	[14]	0,1
3631	SHORT	RD	V	Harmonic U L3	[15]	0,1
3632	SHORT	RD	V	Harmonic U L3	[16]	0,1
3633	SHORT	RD	V	Harmonic U L3	[17]	0,1
3634	SHORT	RD	V	Harmonic U L3	[18]	0,1
3635	SHORT	RD	V	Harmonic U L3	[19]	0,1
3636	SHORT	RD	V	Harmonic U L3	[20]	0,1
3637	SHORT	RD	V	Harmonic U L3	[21]	0,1
3638	SHORT	RD	V	Harmonic U L3	[22]	0,1
3639	SHORT	RD	V	Harmonic U L3	[23]	0,1
3640	SHORT	RD	V	Harmonic U L3	[24]	0,1
3641	SHORT	RD	V	Harmonic U L3	[25]	0,1
3642	SHORT	RD	V	Harmonic U L3	[26]	0,1
3643	SHORT	RD	V	Harmonic U L3	[27]	0,1
3644	SHORT	RD	V	Harmonic U L3	[28]	0,1
3645	SHORT	RD	V	Harmonic U L3	[29]	0,1
3646	SHORT	RD	V	Harmonic U L3	[30]	0,1
3647	SHORT	RD	V	Harmonic U L3	[31]	0,1
3648	SHORT	RD	V	Harmonic U L3	[32]	0,1
3649	SHORT	RD	V	Harmonic U L3	[33]	0,1
3650	SHORT	RD	V	Harmonic U L3	[34]	0,1
3651	SHORT	RD	V	Harmonic U L3	[35]	0,1
3652	SHORT	RD	V	Harmonic U L3	[36]	0,1
3653	SHORT	RD	V	Harmonic U L3	[37]	0,1
3654	SHORT	RD	V	Harmonic U L3	[38]	0,1
3655	SHORT	RD	V	Harmonic U L3	[39]	0,1
3656	SHORT	RD	V	Harmonic U L1-L2	[0]	0,1
3657	SHORT	RD	V	Harmonic U L1-L2	[1]	0,1
3658	SHORT	RD	V	Harmonic U L1-L2	[2]	0,1
3659	SHORT	RD	V	Harmonic U L1-L2	[3]	0,1
3660	SHORT	RD	V	Harmonic U L1-L2	[4]	0,1
3661	SHORT	RD	V	Harmonic U L1-L2	[5]	0,1
3662	SHORT	RD	V	Harmonic U L1-L2	[6]	0,1
3663	SHORT	RD	V	Harmonic U L1-L2	[7]	0,1
3664	SHORT	RD	V	Harmonic U L1-L2	[8]	0,1
3665	SHORT	RD	V	Harmonic U L1-L2	[9]	0,1
3666	SHORT	RD	V	Harmonic U L1-L2	[10]	0,1
3667	SHORT	RD	V	Harmonic U L1-L2	[11]	0,1

Address	Format	RD/WR	Unit	Note	Index	Resolution
3668	SHORT	RD	V	Harmonic U L1-L2	[12]	0,1
3669	SHORT	RD	V	Harmonic U L1-L2	[13]	0,1
3670	SHORT	RD	V	Harmonic U L1-L2	[14]	0,1
3671	SHORT	RD	V	Harmonic U L1-L2	[15]	0,1
3672	SHORT	RD	V	Harmonic U L1-L2	[16]	0,1
3673	SHORT	RD	V	Harmonic U L1-L2	[17]	0,1
3674	SHORT	RD	V	Harmonic U L1-L2	[18]	0,1
3675	SHORT	RD	V	Harmonic U L1-L2	[19]	0,1
3676	SHORT	RD	V	Harmonic U L1-L2	[20]	0,1
3677	SHORT	RD	V	Harmonic U L1-L2	[21]	0,1
3678	SHORT	RD	V	Harmonic U L1-L2	[22]	0,1
3679	SHORT	RD	V	Harmonic U L1-L2	[23]	0,1
3680	SHORT	RD	V	Harmonic U L1-L2	[24]	0,1
3681	SHORT	RD	V	Harmonic U L1-L2	[25]	0,1
3682	SHORT	RD	V	Harmonic U L1-L2	[26]	0,1
3683	SHORT	RD	V	Harmonic U L1-L2	[27]	0,1
3684	SHORT	RD	V	Harmonic U L1-L2	[28]	0,1
3685	SHORT	RD	V	Harmonic U L1-L2	[29]	0,1
3686	SHORT	RD	V	Harmonic U L1-L2	[30]	0,1
3687	SHORT	RD	V	Harmonic U L1-L2	[31]	0,1
3688	SHORT	RD	V	Harmonic U L1-L2	[32]	0,1
3689	SHORT	RD	V	Harmonic U L1-L2	[33]	0,1
3690	SHORT	RD	V	Harmonic U L1-L2	[34]	0,1
3691	SHORT	RD	V	Harmonic U L1-L2	[35]	0,1
3692	SHORT	RD	V	Harmonic U L1-L2	[36]	0,1
3693	SHORT	RD	V	Harmonic U L1-L2	[37]	0,1
3694	SHORT	RD	V	Harmonic U L1-L2	[38]	0,1
3695	SHORT	RD	V	Harmonic U L1-L2	[39]	0,1
3696	SHORT	RD	V	Harmonic U L2-L3	[0]	0,1
3697	SHORT	RD	V	Harmonic U L2-L3	[1]	0,1
3698	SHORT	RD	V	Harmonic U L2-L3	[2]	0,1
3699	SHORT	RD	V	Harmonic U L2-L3	[3]	0,1
3700	SHORT	RD	V	Harmonic U L2-L3	[4]	0,1
3701	SHORT	RD	V	Harmonic U L2-L3	[5]	0,1
3702	SHORT	RD	V	Harmonic U L2-L3	[6]	0,1
3703	SHORT	RD	V	Harmonic U L2-L3	[7]	0,1
3704	SHORT	RD	V	Harmonic U L2-L3	[8]	0,1
3705	SHORT	RD	V	Harmonic U L2-L3	[9]	0,1
3706	SHORT	RD	V	Harmonic U L2-L3	[10]	0,1
3707	SHORT	RD	V	Harmonic U L2-L3	[11]	0,1
3708	SHORT	RD	V	Harmonic U L2-L3	[12]	0,1
3709	SHORT	RD	V	Harmonic U L2-L3	[13]	0,1
3710	SHORT	RD	V	Harmonic U L2-L3	[14]	0,1
3711	SHORT	RD	V	Harmonic U L2-L3	[15]	0,1
3712	SHORT	RD	V	Harmonic U L2-L3	[16]	0,1
3713	SHORT	RD	V	Harmonic U L2-L3	[17]	0,1
3714	SHORT	RD	V	Harmonic U L2-L3	[18]	0,1
3715	SHORT	RD	V	Harmonic U L2-L3	[19]	0,1
3716	SHORT	RD	V	Harmonic U L2-L3	[20]	0,1
3717	SHORT	RD	V	Harmonic U L2-L3	[21]	0,1
3718	SHORT	RD	V	Harmonic U L2-L3	[22]	0,1
3719	SHORT	RD	V	Harmonic U L2-L3	[23]	0,1
3720	SHORT	RD	V	Harmonic U L2-L3	[24]	0,1
3721	SHORT	RD	V	Harmonic U L2-L3	[25]	0,1
3722	SHORT	RD	V	Harmonic U L2-L3	[26]	0,1
3723	SHORT	RD	V	Harmonic U L2-L3	[27]	0,1
3724	SHORT	RD	V	Harmonic U L2-L3	[28]	0,1
3725	SHORT	RD	V	Harmonic U L2-L3	[29]	0,1
3726	SHORT	RD	V	Harmonic U L2-L3	[30]	0,1
3727	SHORT	RD	V	Harmonic U L2-L3	[31]	0,1
3728	SHORT	RD	V	Harmonic U L2-L3	[32]	0,1
3729	SHORT	RD	V	Harmonic U L2-L3	[33]	0,1
3730	SHORT	RD	V	Harmonic U L2-L3	[34]	0,1
3731	SHORT	RD	V	Harmonic U L2-L3	[35]	0,1
3732	SHORT	RD	V	Harmonic U L2-L3	[36]	0,1
3733	SHORT	RD	V	Harmonic U L2-L3	[37]	0,1

Address	Format	RD/WR	Unit	Note	Index	Resolution
3734	SHORT	RD	V	Harmonic U L2-L3	[38]	0,1
3735	SHORT	RD	V	Harmonic U L2-L3	[39]	0,1
3736	SHORT	RD	V	Harmonic U L3-L1	[0]	0,1
3737	SHORT	RD	V	Harmonic U L3-L1	[1]	0,1
3738	SHORT	RD	V	Harmonic U L3-L1	[2]	0,1
3739	SHORT	RD	V	Harmonic U L3-L1	[3]	0,1
3740	SHORT	RD	V	Harmonic U L3-L1	[4]	0,1
3741	SHORT	RD	V	Harmonic U L3-L1	[5]	0,1
3742	SHORT	RD	V	Harmonic U L3-L1	[6]	0,1
3743	SHORT	RD	V	Harmonic U L3-L1	[7]	0,1
3744	SHORT	RD	V	Harmonic U L3-L1	[8]	0,1
3745	SHORT	RD	V	Harmonic U L3-L1	[9]	0,1
3746	SHORT	RD	V	Harmonic U L3-L1	[10]	0,1
3747	SHORT	RD	V	Harmonic U L3-L1	[11]	0,1
3748	SHORT	RD	V	Harmonic U L3-L1	[12]	0,1
3749	SHORT	RD	V	Harmonic U L3-L1	[13]	0,1
3750	SHORT	RD	V	Harmonic U L3-L1	[14]	0,1
3751	SHORT	RD	V	Harmonic U L3-L1	[15]	0,1
3752	SHORT	RD	V	Harmonic U L3-L1	[16]	0,1
3753	SHORT	RD	V	Harmonic U L3-L1	[17]	0,1
3754	SHORT	RD	V	Harmonic U L3-L1	[18]	0,1
3755	SHORT	RD	V	Harmonic U L3-L1	[19]	0,1
3756	SHORT	RD	V	Harmonic U L3-L1	[20]	0,1
3757	SHORT	RD	V	Harmonic U L3-L1	[21]	0,1
3758	SHORT	RD	V	Harmonic U L3-L1	[22]	0,1
3759	SHORT	RD	V	Harmonic U L3-L1	[23]	0,1
3760	SHORT	RD	V	Harmonic U L3-L1	[24]	0,1
3761	SHORT	RD	V	Harmonic U L3-L1	[25]	0,1
3762	SHORT	RD	V	Harmonic U L3-L1	[26]	0,1
3763	SHORT	RD	V	Harmonic U L3-L1	[27]	0,1
3764	SHORT	RD	V	Harmonic U L3-L1	[28]	0,1
3765	SHORT	RD	V	Harmonic U L3-L1	[29]	0,1
3766	SHORT	RD	V	Harmonic U L3-L1	[30]	0,1
3767	SHORT	RD	V	Harmonic U L3-L1	[31]	0,1
3768	SHORT	RD	V	Harmonic U L3-L1	[32]	0,1
3769	SHORT	RD	V	Harmonic U L3-L1	[33]	0,1
3770	SHORT	RD	V	Harmonic U L3-L1	[34]	0,1
3771	SHORT	RD	V	Harmonic U L3-L1	[35]	0,1
3772	SHORT	RD	V	Harmonic U L3-L1	[36]	0,1
3773	SHORT	RD	V	Harmonic U L3-L1	[37]	0,1
3774	SHORT	RD	V	Harmonic U L3-L1	[38]	0,1
3775	SHORT	RD	V	Harmonic U L3-L1	[39]	0,1
3796	SHORT	RD	mA	Harmonic I L1	[0]	1
3797	SHORT	RD	mA	Harmonic I L1	[1]	1
3798	SHORT	RD	mA	Harmonic I L1	[2]	1
3799	SHORT	RD	mA	Harmonic I L1	[3]	1
3800	SHORT	RD	mA	Harmonic I L1	[4]	1
3801	SHORT	RD	mA	Harmonic I L1	[5]	1
3802	SHORT	RD	mA	Harmonic I L1	[6]	1
3803	SHORT	RD	mA	Harmonic I L1	[7]	1
3804	SHORT	RD	mA	Harmonic I L1	[8]	1
3805	SHORT	RD	mA	Harmonic I L1	[9]	1
3806	SHORT	RD	mA	Harmonic I L1	[10]	1
3807	SHORT	RD	mA	Harmonic I L1	[11]	1
3808	SHORT	RD	mA	Harmonic I L1	[12]	1
3809	SHORT	RD	mA	Harmonic I L1	[13]	1
3810	SHORT	RD	mA	Harmonic I L1	[14]	1
3811	SHORT	RD	mA	Harmonic I L1	[15]	1
3812	SHORT	RD	mA	Harmonic I L1	[16]	1
3813	SHORT	RD	mA	Harmonic I L1	[17]	1
3814	SHORT	RD	mA	Harmonic I L1	[18]	1
3815	SHORT	RD	mA	Harmonic I L1	[19]	1
3816	SHORT	RD	mA	Harmonic I L1	[20]	1
3817	SHORT	RD	mA	Harmonic I L1	[21]	1
3818	SHORT	RD	mA	Harmonic I L1	[22]	1
3819	SHORT	RD	mA	Harmonic I L1	[23]	1

Address	Format	RD/WR	Unit	Note	Index	Resolution
3820	SHORT	RD	mA	Harmonic I L1	[24]	1
3821	SHORT	RD	mA	Harmonic I L1	[25]	1
3822	SHORT	RD	mA	Harmonic I L1	[26]	1
3823	SHORT	RD	mA	Harmonic I L1	[27]	1
3824	SHORT	RD	mA	Harmonic I L1	[28]	1
3825	SHORT	RD	mA	Harmonic I L1	[29]	1
3826	SHORT	RD	mA	Harmonic I L1	[30]	1
3827	SHORT	RD	mA	Harmonic I L1	[31]	1
3828	SHORT	RD	mA	Harmonic I L1	[32]	1
3829	SHORT	RD	mA	Harmonic I L1	[33]	1
3830	SHORT	RD	mA	Harmonic I L1	[34]	1
3831	SHORT	RD	mA	Harmonic I L1	[35]	1
3832	SHORT	RD	mA	Harmonic I L1	[36]	1
3833	SHORT	RD	mA	Harmonic I L1	[37]	1
3834	SHORT	RD	mA	Harmonic I L1	[38]	1
3835	SHORT	RD	mA	Harmonic I L1	[39]	1
3836	SHORT	RD	mA	Harmonic I L2	[0]	1
3837	SHORT	RD	mA	Harmonic I L2	[1]	1
3838	SHORT	RD	mA	Harmonic I L2	[2]	1
3839	SHORT	RD	mA	Harmonic I L2	[3]	1
3840	SHORT	RD	mA	Harmonic I L2	[4]	1
3841	SHORT	RD	mA	Harmonic I L2	[5]	1
3842	SHORT	RD	mA	Harmonic I L2	[6]	1
3843	SHORT	RD	mA	Harmonic I L2	[7]	1
3844	SHORT	RD	mA	Harmonic I L2	[8]	1
3845	SHORT	RD	mA	Harmonic I L2	[9]	1
3846	SHORT	RD	mA	Harmonic I L2	[10]	1
3847	SHORT	RD	mA	Harmonic I L2	[11]	1
3848	SHORT	RD	mA	Harmonic I L2	[12]	1
3849	SHORT	RD	mA	Harmonic I L2	[13]	1
3850	SHORT	RD	mA	Harmonic I L2	[14]	1
3851	SHORT	RD	mA	Harmonic I L2	[15]	1
3852	SHORT	RD	mA	Harmonic I L2	[16]	1
3853	SHORT	RD	mA	Harmonic I L2	[17]	1
3854	SHORT	RD	mA	Harmonic I L2	[18]	1
3855	SHORT	RD	mA	Harmonic I L2	[19]	1
3856	SHORT	RD	mA	Harmonic I L2	[20]	1
3857	SHORT	RD	mA	Harmonic I L2	[21]	1
3858	SHORT	RD	mA	Harmonic I L2	[22]	1
3859	SHORT	RD	mA	Harmonic I L2	[23]	1
3860	SHORT	RD	mA	Harmonic I L2	[24]	1
3861	SHORT	RD	mA	Harmonic I L2	[25]	1
3862	SHORT	RD	mA	Harmonic I L2	[26]	1
3863	SHORT	RD	mA	Harmonic I L2	[27]	1
3864	SHORT	RD	mA	Harmonic I L2	[28]	1
3865	SHORT	RD	mA	Harmonic I L2	[29]	1
3866	SHORT	RD	mA	Harmonic I L2	[30]	1
3867	SHORT	RD	mA	Harmonic I L2	[31]	1
3868	SHORT	RD	mA	Harmonic I L2	[32]	1
3869	SHORT	RD	mA	Harmonic I L2	[33]	1
3870	SHORT	RD	mA	Harmonic I L2	[34]	1
3871	SHORT	RD	mA	Harmonic I L2	[35]	1
3872	SHORT	RD	mA	Harmonic I L2	[36]	1
3873	SHORT	RD	mA	Harmonic I L2	[37]	1
3874	SHORT	RD	mA	Harmonic I L2	[38]	1
3875	SHORT	RD	mA	Harmonic I L2	[39]	1
3876	SHORT	RD	mA	Harmonic I L3	[0]	1
3877	SHORT	RD	mA	Harmonic I L3	[1]	1
3878	SHORT	RD	mA	Harmonic I L3	[2]	1
3879	SHORT	RD	mA	Harmonic I L3	[3]	1
3880	SHORT	RD	mA	Harmonic I L3	[4]	1
3881	SHORT	RD	mA	Harmonic I L3	[5]	1
3882	SHORT	RD	mA	Harmonic I L3	[6]	1
3883	SHORT	RD	mA	Harmonic I L3	[7]	1
3884	SHORT	RD	mA	Harmonic I L3	[8]	1
3885	SHORT	RD	mA	Harmonic I L3	[9]	1

Address	Format	RD/WR	Unit	Note	Index	Resolution
3886	SHORT	RD	mA	Harmonic I L3	[10]	1
3887	SHORT	RD	mA	Harmonic I L3	[11]	1
3888	SHORT	RD	mA	Harmonic I L3	[12]	1
3889	SHORT	RD	mA	Harmonic I L3	[13]	1
3890	SHORT	RD	mA	Harmonic I L3	[14]	1
3891	SHORT	RD	mA	Harmonic I L3	[15]	1
3892	SHORT	RD	mA	Harmonic I L3	[16]	1
3893	SHORT	RD	mA	Harmonic I L3	[17]	1
3894	SHORT	RD	mA	Harmonic I L3	[18]	1
3895	SHORT	RD	mA	Harmonic I L3	[19]	1
3896	SHORT	RD	mA	Harmonic I L3	[20]	1
3897	SHORT	RD	mA	Harmonic I L3	[21]	1
3898	SHORT	RD	mA	Harmonic I L3	[22]	1
3899	SHORT	RD	mA	Harmonic I L3	[23]	1
3900	SHORT	RD	mA	Harmonic I L3	[24]	1
3901	SHORT	RD	mA	Harmonic I L3	[25]	1
3902	SHORT	RD	mA	Harmonic I L3	[26]	1
3903	SHORT	RD	mA	Harmonic I L3	[27]	1
3904	SHORT	RD	mA	Harmonic I L3	[28]	1
3905	SHORT	RD	mA	Harmonic I L3	[29]	1
3906	SHORT	RD	mA	Harmonic I L3	[30]	1
3907	SHORT	RD	mA	Harmonic I L3	[31]	1
3908	SHORT	RD	mA	Harmonic I L3	[32]	1
3909	SHORT	RD	mA	Harmonic I L3	[33]	1
3910	SHORT	RD	mA	Harmonic I L3	[34]	1
3911	SHORT	RD	mA	Harmonic I L3	[35]	1
3912	SHORT	RD	mA	Harmonic I L3	[36]	1
3913	SHORT	RD	mA	Harmonic I L3	[37]	1
3914	SHORT	RD	mA	Harmonic I L3	[38]	1
3915	SHORT	RD	mA	Harmonic I L3	[39]	1

Mean values, type float, fourier analysis

Address	Format	RD/WR	Unit	Note	Index
1740	FLOAT	RD	V	Average, Harmonic U L1	[0]
1742	FLOAT	RD	V	Average, Harmonic U L1	[1]
1744	FLOAT	RD	V	Average, Harmonic U L1	[2]
1746	FLOAT	RD	V	Average, Harmonic U L1	[3]
1748	FLOAT	RD	V	Average, Harmonic U L1	[4]
1750	FLOAT	RD	V	Average, Harmonic U L1	[5]
1752	FLOAT	RD	V	Average, Harmonic U L1	[6]
1754	FLOAT	RD	V	Average, Harmonic U L1	[7]
1756	FLOAT	RD	V	Average, Harmonic U L1	[8]
1758	FLOAT	RD	V	Average, Harmonic U L1	[9]
1760	FLOAT	RD	V	Average, Harmonic U L1	[10]
1762	FLOAT	RD	V	Average, Harmonic U L1	[11]
1764	FLOAT	RD	V	Average, Harmonic U L1	[12]
1766	FLOAT	RD	V	Average, Harmonic U L1	[13]
1768	FLOAT	RD	V	Average, Harmonic U L1	[14]
1770	FLOAT	RD	V	Average, Harmonic U L1	[15]
1772	FLOAT	RD	V	Average, Harmonic U L1	[16]
1774	FLOAT	RD	V	Average, Harmonic U L1	[17]
1776	FLOAT	RD	V	Average, Harmonic U L1	[18]
1778	FLOAT	RD	V	Average, Harmonic U L1	[19]
1780	FLOAT	RD	V	Average, Harmonic U L1	[20]
1782	FLOAT	RD	V	Average, Harmonic U L1	[21]
1784	FLOAT	RD	V	Average, Harmonic U L1	[22]
1786	FLOAT	RD	V	Average, Harmonic U L1	[23]
1788	FLOAT	RD	V	Average, Harmonic U L1	[24]
1790	FLOAT	RD	V	Average, Harmonic U L1	[25]
1792	FLOAT	RD	V	Average, Harmonic U L1	[26]
1794	FLOAT	RD	V	Average, Harmonic U L1	[27]
1796	FLOAT	RD	V	Average, Harmonic U L1	[28]
1798	FLOAT	RD	V	Average, Harmonic U L1	[29]
1800	FLOAT	RD	V	Average, Harmonic U L1	[30]
1802	FLOAT	RD	V	Average, Harmonic U L1	[31]
1804	FLOAT	RD	V	Average, Harmonic U L1	[32]
1806	FLOAT	RD	V	Average, Harmonic U L1	[33]
1808	FLOAT	RD	V	Average, Harmonic U L1	[34]
1810	FLOAT	RD	V	Average, Harmonic U L1	[35]
1812	FLOAT	RD	V	Average, Harmonic U L1	[36]
1814	FLOAT	RD	V	Average, Harmonic U L1	[37]
1816	FLOAT	RD	V	Average, Harmonic U L1	[38]
1818	FLOAT	RD	V	Average, Harmonic U L1	[39]
1820	FLOAT	RD	V	Average, Harmonic U L2	[0]
1822	FLOAT	RD	V	Average, Harmonic U L2	[1]
1824	FLOAT	RD	V	Average, Harmonic U L2	[2]
1826	FLOAT	RD	V	Average, Harmonic U L2	[3]
1828	FLOAT	RD	V	Average, Harmonic U L2	[4]
1830	FLOAT	RD	V	Average, Harmonic U L2	[5]
1832	FLOAT	RD	V	Average, Harmonic U L2	[6]
1834	FLOAT	RD	V	Average, Harmonic U L2	[7]
1836	FLOAT	RD	V	Average, Harmonic U L2	[8]
1838	FLOAT	RD	V	Average, Harmonic U L2	[9]
1840	FLOAT	RD	V	Average, Harmonic U L2	[10]
1842	FLOAT	RD	V	Average, Harmonic U L2	[11]
1844	FLOAT	RD	V	Average, Harmonic U L2	[12]
1846	FLOAT	RD	V	Average, Harmonic U L2	[13]
1848	FLOAT	RD	V	Average, Harmonic U L2	[14]
1850	FLOAT	RD	V	Average, Harmonic U L2	[15]
1852	FLOAT	RD	V	Average, Harmonic U L2	[16]
1854	FLOAT	RD	V	Average, Harmonic U L2	[17]
1856	FLOAT	RD	V	Average, Harmonic U L2	[18]
1858	FLOAT	RD	V	Average, Harmonic U L2	[19]
1860	FLOAT	RD	V	Average, Harmonic U L2	[20]
1862	FLOAT	RD	V	Average, Harmonic U L2	[21]
1864	FLOAT	RD	V	Average, Harmonic U L2	[22]
1866	FLOAT	RD	V	Average, Harmonic U L2	[23]
1868	FLOAT	RD	V	Average, Harmonic U L2	[24]
1870	FLOAT	RD	V	Average, Harmonic U L2	[25]

Address	Format	RD/WR	Unit	Note	Index
1872	FLOAT	RD	V	Average, Harmonic U L2	[26]
1874	FLOAT	RD	V	Average, Harmonic U L2	[27]
1876	FLOAT	RD	V	Average, Harmonic U L2	[28]
1878	FLOAT	RD	V	Average, Harmonic U L2	[29]
1880	FLOAT	RD	V	Average, Harmonic U L2	[30]
1882	FLOAT	RD	V	Average, Harmonic U L2	[31]
1884	FLOAT	RD	V	Average, Harmonic U L2	[32]
1886	FLOAT	RD	V	Average, Harmonic U L2	[33]
1888	FLOAT	RD	V	Average, Harmonic U L2	[34]
1890	FLOAT	RD	V	Average, Harmonic U L2	[35]
1892	FLOAT	RD	V	Average, Harmonic U L2	[36]
1894	FLOAT	RD	V	Average, Harmonic U L2	[37]
1896	FLOAT	RD	V	Average, Harmonic U L2	[38]
1898	FLOAT	RD	V	Average, Harmonic U L2	[39]
1900	FLOAT	RD	V	Average, Harmonic U L3	[0]
1902	FLOAT	RD	V	Average, Harmonic U L3	[1]
1904	FLOAT	RD	V	Average, Harmonic U L3	[2]
1906	FLOAT	RD	V	Average, Harmonic U L3	[3]
1908	FLOAT	RD	V	Average, Harmonic U L3	[4]
1910	FLOAT	RD	V	Average, Harmonic U L3	[5]
1912	FLOAT	RD	V	Average, Harmonic U L3	[6]
1914	FLOAT	RD	V	Average, Harmonic U L3	[7]
1916	FLOAT	RD	V	Average, Harmonic U L3	[8]
1918	FLOAT	RD	V	Average, Harmonic U L3	[9]
1920	FLOAT	RD	V	Average, Harmonic U L3	[10]
1922	FLOAT	RD	V	Average, Harmonic U L3	[11]
1924	FLOAT	RD	V	Average, Harmonic U L3	[12]
1926	FLOAT	RD	V	Average, Harmonic U L3	[13]
1928	FLOAT	RD	V	Average, Harmonic U L3	[14]
1930	FLOAT	RD	V	Average, Harmonic U L3	[15]
1932	FLOAT	RD	V	Average, Harmonic U L3	[16]
1934	FLOAT	RD	V	Average, Harmonic U L3	[17]
1936	FLOAT	RD	V	Average, Harmonic U L3	[18]
1938	FLOAT	RD	V	Average, Harmonic U L3	[19]
1940	FLOAT	RD	V	Average, Harmonic U L3	[20]
1942	FLOAT	RD	V	Average, Harmonic U L3	[21]
1944	FLOAT	RD	V	Average, Harmonic U L3	[22]
1946	FLOAT	RD	V	Average, Harmonic U L3	[23]
1948	FLOAT	RD	V	Average, Harmonic U L3	[24]
1950	FLOAT	RD	V	Average, Harmonic U L3	[25]
1952	FLOAT	RD	V	Average, Harmonic U L3	[26]
1954	FLOAT	RD	V	Average, Harmonic U L3	[27]
1956	FLOAT	RD	V	Average, Harmonic U L3	[28]
1958	FLOAT	RD	V	Average, Harmonic U L3	[29]
1960	FLOAT	RD	V	Average, Harmonic U L3	[30]
1962	FLOAT	RD	V	Average, Harmonic U L3	[31]
1964	FLOAT	RD	V	Average, Harmonic U L3	[32]
1966	FLOAT	RD	V	Average, Harmonic U L3	[33]
1968	FLOAT	RD	V	Average, Harmonic U L3	[34]
1970	FLOAT	RD	V	Average, Harmonic U L3	[35]
1972	FLOAT	RD	V	Average, Harmonic U L3	[36]
1974	FLOAT	RD	V	Average, Harmonic U L3	[37]
1976	FLOAT	RD	V	Average, Harmonic U L3	[38]
1978	FLOAT	RD	V	Average, Harmonic U L3	[39]
1980	FLOAT	RD	V	Average, Harmonic U L1-L2	[0]
1982	FLOAT	RD	V	Average, Harmonic U L1-L2	[1]
1984	FLOAT	RD	V	Average, Harmonic U L1-L2	[2]
1986	FLOAT	RD	V	Average, Harmonic U L1-L2	[3]
1988	FLOAT	RD	V	Average, Harmonic U L1-L2	[4]
1990	FLOAT	RD	V	Average, Harmonic U L1-L2	[5]
1992	FLOAT	RD	V	Average, Harmonic U L1-L2	[6]
1994	FLOAT	RD	V	Average, Harmonic U L1-L2	[7]
1996	FLOAT	RD	V	Average, Harmonic U L1-L2	[8]
1998	FLOAT	RD	V	Average, Harmonic U L1-L2	[9]
2000	FLOAT	RD	V	Average, Harmonic U L1-L2	[10]
2002	FLOAT	RD	V	Average, Harmonic U L1-L2	[11]

Address	Format	RD/WR	Unit	Note	Index
2004	FLOAT	RD	V	Average, Harmonic U L1-L2	[12]
2006	FLOAT	RD	V	Average, Harmonic U L1-L2	[13]
2008	FLOAT	RD	V	Average, Harmonic U L1-L2	[14]
2010	FLOAT	RD	V	Average, Harmonic U L1-L2	[15]
2012	FLOAT	RD	V	Average, Harmonic U L1-L2	[16]
2014	FLOAT	RD	V	Average, Harmonic U L1-L2	[17]
2016	FLOAT	RD	V	Average, Harmonic U L1-L2	[18]
2018	FLOAT	RD	V	Average, Harmonic U L1-L2	[19]
2020	FLOAT	RD	V	Average, Harmonic U L1-L2	[20]
2022	FLOAT	RD	V	Average, Harmonic U L1-L2	[21]
2024	FLOAT	RD	V	Average, Harmonic U L1-L2	[22]
2026	FLOAT	RD	V	Average, Harmonic U L1-L2	[23]
2028	FLOAT	RD	V	Average, Harmonic U L1-L2	[24]
2030	FLOAT	RD	V	Average, Harmonic U L1-L2	[25]
2032	FLOAT	RD	V	Average, Harmonic U L1-L2	[26]
2034	FLOAT	RD	V	Average, Harmonic U L1-L2	[27]
2036	FLOAT	RD	V	Average, Harmonic U L1-L2	[28]
2038	FLOAT	RD	V	Average, Harmonic U L1-L2	[29]
2040	FLOAT	RD	V	Average, Harmonic U L1-L2	[30]
2042	FLOAT	RD	V	Average, Harmonic U L1-L2	[31]
2044	FLOAT	RD	V	Average, Harmonic U L1-L2	[32]
2046	FLOAT	RD	V	Average, Harmonic U L1-L2	[33]
2048	FLOAT	RD	V	Average, Harmonic U L1-L2	[34]
2050	FLOAT	RD	V	Average, Harmonic U L1-L2	[35]
2052	FLOAT	RD	V	Average, Harmonic U L1-L2	[36]
2054	FLOAT	RD	V	Average, Harmonic U L1-L2	[37]
2056	FLOAT	RD	V	Average, Harmonic U L1-L2	[38]
2058	FLOAT	RD	V	Average, Harmonic U L1-L2	[39]
2060	FLOAT	RD	V	Average, Harmonic U L2-L3	[0]
2062	FLOAT	RD	V	Average, Harmonic U L2-L3	[1]
2064	FLOAT	RD	V	Average, Harmonic U L2-L3	[2]
2066	FLOAT	RD	V	Average, Harmonic U L2-L3	[3]
2068	FLOAT	RD	V	Average, Harmonic U L2-L3	[4]
2070	FLOAT	RD	V	Average, Harmonic U L2-L3	[5]
2072	FLOAT	RD	V	Average, Harmonic U L2-L3	[6]
2074	FLOAT	RD	V	Average, Harmonic U L2-L3	[7]
2076	FLOAT	RD	V	Average, Harmonic U L2-L3	[8]
2078	FLOAT	RD	V	Average, Harmonic U L2-L3	[9]
2080	FLOAT	RD	V	Average, Harmonic U L2-L3	[10]
2082	FLOAT	RD	V	Average, Harmonic U L2-L3	[11]
2084	FLOAT	RD	V	Average, Harmonic U L2-L3	[12]
2086	FLOAT	RD	V	Average, Harmonic U L2-L3	[13]
2088	FLOAT	RD	V	Average, Harmonic U L2-L3	[14]
2090	FLOAT	RD	V	Average, Harmonic U L2-L3	[15]
2092	FLOAT	RD	V	Average, Harmonic U L2-L3	[16]
2094	FLOAT	RD	V	Average, Harmonic U L2-L3	[17]
2096	FLOAT	RD	V	Average, Harmonic U L2-L3	[18]
2098	FLOAT	RD	V	Average, Harmonic U L2-L3	[19]
2100	FLOAT	RD	V	Average, Harmonic U L2-L3	[20]
2102	FLOAT	RD	V	Average, Harmonic U L2-L3	[21]
2104	FLOAT	RD	V	Average, Harmonic U L2-L3	[22]
2106	FLOAT	RD	V	Average, Harmonic U L2-L3	[23]
2108	FLOAT	RD	V	Average, Harmonic U L2-L3	[24]
2110	FLOAT	RD	V	Average, Harmonic U L2-L3	[25]
2112	FLOAT	RD	V	Average, Harmonic U L2-L3	[26]
2114	FLOAT	RD	V	Average, Harmonic U L2-L3	[27]
2116	FLOAT	RD	V	Average, Harmonic U L2-L3	[28]
2118	FLOAT	RD	V	Average, Harmonic U L2-L3	[29]
2120	FLOAT	RD	V	Average, Harmonic U L2-L3	[30]
2122	FLOAT	RD	V	Average, Harmonic U L2-L3	[31]
2124	FLOAT	RD	V	Average, Harmonic U L2-L3	[32]
2126	FLOAT	RD	V	Average, Harmonic U L2-L3	[33]
2128	FLOAT	RD	V	Average, Harmonic U L2-L3	[34]
2130	FLOAT	RD	V	Average, Harmonic U L2-L3	[35]
2132	FLOAT	RD	V	Average, Harmonic U L2-L3	[36]
2134	FLOAT	RD	V	Average, Harmonic U L2-L3	[37]

Address	Format	RD/WR	Unit	Note	Index
2136	FLOAT	RD	V	Average, Harmonic U L2-L3	[38]
2138	FLOAT	RD	V	Average, Harmonic U L2-L3	[39]
2140	FLOAT	RD	V	Average, Harmonic U L3-L1	[0]
2142	FLOAT	RD	V	Average, Harmonic U L3-L1	[1]
2144	FLOAT	RD	V	Average, Harmonic U L3-L1	[2]
2146	FLOAT	RD	V	Average, Harmonic U L3-L1	[3]
2148	FLOAT	RD	V	Average, Harmonic U L3-L1	[4]
2150	FLOAT	RD	V	Average, Harmonic U L3-L1	[5]
2152	FLOAT	RD	V	Average, Harmonic U L3-L1	[6]
2154	FLOAT	RD	V	Average, Harmonic U L3-L1	[7]
2156	FLOAT	RD	V	Average, Harmonic U L3-L1	[8]
2158	FLOAT	RD	V	Average, Harmonic U L3-L1	[9]
2160	FLOAT	RD	V	Average, Harmonic U L3-L1	[10]
2162	FLOAT	RD	V	Average, Harmonic U L3-L1	[11]
2164	FLOAT	RD	V	Average, Harmonic U L3-L1	[12]
2166	FLOAT	RD	V	Average, Harmonic U L3-L1	[13]
2168	FLOAT	RD	V	Average, Harmonic U L3-L1	[14]
2170	FLOAT	RD	V	Average, Harmonic U L3-L1	[15]
2172	FLOAT	RD	V	Average, Harmonic U L3-L1	[16]
2174	FLOAT	RD	V	Average, Harmonic U L3-L1	[17]
2176	FLOAT	RD	V	Average, Harmonic U L3-L1	[18]
2178	FLOAT	RD	V	Average, Harmonic U L3-L1	[19]
2180	FLOAT	RD	V	Average, Harmonic U L3-L1	[20]
2182	FLOAT	RD	V	Average, Harmonic U L3-L1	[21]
2184	FLOAT	RD	V	Average, Harmonic U L3-L1	[22]
2186	FLOAT	RD	V	Average, Harmonic U L3-L1	[23]
2188	FLOAT	RD	V	Average, Harmonic U L3-L1	[24]
2190	FLOAT	RD	V	Average, Harmonic U L3-L1	[25]
2192	FLOAT	RD	V	Average, Harmonic U L3-L1	[26]
2194	FLOAT	RD	V	Average, Harmonic U L3-L1	[27]
2196	FLOAT	RD	V	Average, Harmonic U L3-L1	[28]
2198	FLOAT	RD	V	Average, Harmonic U L3-L1	[29]
2200	FLOAT	RD	V	Average, Harmonic U L3-L1	[30]
2202	FLOAT	RD	V	Average, Harmonic U L3-L1	[31]
2204	FLOAT	RD	V	Average, Harmonic U L3-L1	[32]
2206	FLOAT	RD	V	Average, Harmonic U L3-L1	[33]
2208	FLOAT	RD	V	Average, Harmonic U L3-L1	[34]
2210	FLOAT	RD	V	Average, Harmonic U L3-L1	[35]
2212	FLOAT	RD	V	Average, Harmonic U L3-L1	[36]
2214	FLOAT	RD	V	Average, Harmonic U L3-L1	[37]
2216	FLOAT	RD	V	Average, Harmonic U L3-L1	[38]
2218	FLOAT	RD	V	Average, Harmonic U L3-L1	[39]
2260	FLOAT	RD	A	Average, Harmonic I L1	[0]
2262	FLOAT	RD	A	Average, Harmonic I L1	[1]
2264	FLOAT	RD	A	Average, Harmonic I L1	[2]
2266	FLOAT	RD	A	Average, Harmonic I L1	[3]
2268	FLOAT	RD	A	Average, Harmonic I L1	[4]
2270	FLOAT	RD	A	Average, Harmonic I L1	[5]
2272	FLOAT	RD	A	Average, Harmonic I L1	[6]
2274	FLOAT	RD	A	Average, Harmonic I L1	[7]
2276	FLOAT	RD	A	Average, Harmonic I L1	[8]
2278	FLOAT	RD	A	Average, Harmonic I L1	[9]
2280	FLOAT	RD	A	Average, Harmonic I L1	[10]
2282	FLOAT	RD	A	Average, Harmonic I L1	[11]
2284	FLOAT	RD	A	Average, Harmonic I L1	[12]
2286	FLOAT	RD	A	Average, Harmonic I L1	[13]
2288	FLOAT	RD	A	Average, Harmonic I L1	[14]
2290	FLOAT	RD	A	Average, Harmonic I L1	[15]
2292	FLOAT	RD	A	Average, Harmonic I L1	[16]
2294	FLOAT	RD	A	Average, Harmonic I L1	[17]
2296	FLOAT	RD	A	Average, Harmonic I L1	[18]
2298	FLOAT	RD	A	Average, Harmonic I L1	[19]
2300	FLOAT	RD	A	Average, Harmonic I L1	[20]
2302	FLOAT	RD	A	Average, Harmonic I L1	[21]
2304	FLOAT	RD	A	Average, Harmonic I L1	[22]
2306	FLOAT	RD	A	Average, Harmonic I L1	[23]

Address	Format	RD/WR	Unit	Note	Index
2308	FLOAT	RD	A	Average, Harmonic I L1	[24]
2310	FLOAT	RD	A	Average, Harmonic I L1	[25]
2312	FLOAT	RD	A	Average, Harmonic I L1	[26]
2314	FLOAT	RD	A	Average, Harmonic I L1	[27]
2316	FLOAT	RD	A	Average, Harmonic I L1	[28]
2318	FLOAT	RD	A	Average, Harmonic I L1	[29]
2320	FLOAT	RD	A	Average, Harmonic I L1	[30]
2322	FLOAT	RD	A	Average, Harmonic I L1	[31]
2324	FLOAT	RD	A	Average, Harmonic I L1	[32]
2326	FLOAT	RD	A	Average, Harmonic I L1	[33]
2328	FLOAT	RD	A	Average, Harmonic I L1	[34]
2330	FLOAT	RD	A	Average, Harmonic I L1	[35]
2332	FLOAT	RD	A	Average, Harmonic I L1	[36]
2334	FLOAT	RD	A	Average, Harmonic I L1	[37]
2336	FLOAT	RD	A	Average, Harmonic I L1	[38]
2338	FLOAT	RD	A	Average, Harmonic I L1	[39]
2340	FLOAT	RD	A	Average, Harmonic I L2	[0]
2342	FLOAT	RD	A	Average, Harmonic I L2	[1]
2344	FLOAT	RD	A	Average, Harmonic I L2	[2]
2346	FLOAT	RD	A	Average, Harmonic I L2	[3]
2348	FLOAT	RD	A	Average, Harmonic I L2	[4]
2350	FLOAT	RD	A	Average, Harmonic I L2	[5]
2352	FLOAT	RD	A	Average, Harmonic I L2	[6]
2354	FLOAT	RD	A	Average, Harmonic I L2	[7]
2356	FLOAT	RD	A	Average, Harmonic I L2	[8]
2358	FLOAT	RD	A	Average, Harmonic I L2	[9]
2360	FLOAT	RD	A	Average, Harmonic I L2	[10]
2362	FLOAT	RD	A	Average, Harmonic I L2	[11]
2364	FLOAT	RD	A	Average, Harmonic I L2	[12]
2366	FLOAT	RD	A	Average, Harmonic I L2	[13]
2368	FLOAT	RD	A	Average, Harmonic I L2	[14]
2370	FLOAT	RD	A	Average, Harmonic I L2	[15]
2372	FLOAT	RD	A	Average, Harmonic I L2	[16]
2374	FLOAT	RD	A	Average, Harmonic I L2	[17]
2376	FLOAT	RD	A	Average, Harmonic I L2	[18]
2378	FLOAT	RD	A	Average, Harmonic I L2	[19]
2380	FLOAT	RD	A	Average, Harmonic I L2	[20]
2382	FLOAT	RD	A	Average, Harmonic I L2	[21]
2384	FLOAT	RD	A	Average, Harmonic I L2	[22]
2386	FLOAT	RD	A	Average, Harmonic I L2	[23]
2388	FLOAT	RD	A	Average, Harmonic I L2	[24]
2390	FLOAT	RD	A	Average, Harmonic I L2	[25]
2392	FLOAT	RD	A	Average, Harmonic I L2	[26]
2394	FLOAT	RD	A	Average, Harmonic I L2	[27]
2396	FLOAT	RD	A	Average, Harmonic I L2	[28]
2398	FLOAT	RD	A	Average, Harmonic I L2	[29]
2400	FLOAT	RD	A	Average, Harmonic I L2	[30]
2402	FLOAT	RD	A	Average, Harmonic I L2	[31]
2404	FLOAT	RD	A	Average, Harmonic I L2	[32]
2406	FLOAT	RD	A	Average, Harmonic I L2	[33]
2408	FLOAT	RD	A	Average, Harmonic I L2	[34]
2410	FLOAT	RD	A	Average, Harmonic I L2	[35]
2412	FLOAT	RD	A	Average, Harmonic I L2	[36]
2414	FLOAT	RD	A	Average, Harmonic I L2	[37]
2416	FLOAT	RD	A	Average, Harmonic I L2	[38]
2418	FLOAT	RD	A	Average, Harmonic I L2	[39]
2420	FLOAT	RD	A	Average, Harmonic I L3	[0]
2422	FLOAT	RD	A	Average, Harmonic I L3	[1]
2424	FLOAT	RD	A	Average, Harmonic I L3	[2]
2426	FLOAT	RD	A	Average, Harmonic I L3	[3]
2428	FLOAT	RD	A	Average, Harmonic I L3	[4]
2430	FLOAT	RD	A	Average, Harmonic I L3	[5]
2432	FLOAT	RD	A	Average, Harmonic I L3	[6]
2434	FLOAT	RD	A	Average, Harmonic I L3	[7]
2436	FLOAT	RD	A	Average, Harmonic I L3	[8]
2438	FLOAT	RD	A	Average, Harmonic I L3	[9]

Address	Format	RD/WR	Unit	Note	Index
2440	FLOAT	RD	A	Average, Harmonic I L3	[10]
2442	FLOAT	RD	A	Average, Harmonic I L3	[11]
2444	FLOAT	RD	A	Average, Harmonic I L3	[12]
2446	FLOAT	RD	A	Average, Harmonic I L3	[13]
2448	FLOAT	RD	A	Average, Harmonic I L3	[14]
2450	FLOAT	RD	A	Average, Harmonic I L3	[15]
2452	FLOAT	RD	A	Average, Harmonic I L3	[16]
2454	FLOAT	RD	A	Average, Harmonic I L3	[17]
2456	FLOAT	RD	A	Average, Harmonic I L3	[18]
2458	FLOAT	RD	A	Average, Harmonic I L3	[19]
2460	FLOAT	RD	A	Average, Harmonic I L3	[20]
2462	FLOAT	RD	A	Average, Harmonic I L3	[21]
2464	FLOAT	RD	A	Average, Harmonic I L3	[22]
2466	FLOAT	RD	A	Average, Harmonic I L3	[23]
2468	FLOAT	RD	A	Average, Harmonic I L3	[24]
2470	FLOAT	RD	A	Average, Harmonic I L3	[25]
2472	FLOAT	RD	A	Average, Harmonic I L3	[26]
2474	FLOAT	RD	A	Average, Harmonic I L3	[27]
2476	FLOAT	RD	A	Average, Harmonic I L3	[28]
2478	FLOAT	RD	A	Average, Harmonic I L3	[29]
2480	FLOAT	RD	A	Average, Harmonic I L3	[30]
2482	FLOAT	RD	A	Average, Harmonic I L3	[31]
2484	FLOAT	RD	A	Average, Harmonic I L3	[32]
2486	FLOAT	RD	A	Average, Harmonic I L3	[33]
2488	FLOAT	RD	A	Average, Harmonic I L3	[34]
2490	FLOAT	RD	A	Average, Harmonic I L3	[35]
2492	FLOAT	RD	A	Average, Harmonic I L3	[36]
2494	FLOAT	RD	A	Average, Harmonic I L3	[37]
2496	FLOAT	RD	A	Average, Harmonic I L3	[38]
2498	FLOAT	RD	A	Average, Harmonic I L3	[39]

Mean values, type short, fourier analysis

The measured values in short format do not contain current and voltage transformer ratios.

Address	Format	RD/WR	Unit	Note	Index	Resolution
3966	SHORT	RD	V	Average, Harmonic U L1	[0]	0,1
3967	SHORT	RD	V	Average, Harmonic U L1	[1]	0,1
3968	SHORT	RD	V	Average, Harmonic U L1	[2]	0,1
3969	SHORT	RD	V	Average, Harmonic U L1	[3]	0,1
3970	SHORT	RD	V	Average, Harmonic U L1	[4]	0,1
3971	SHORT	RD	V	Average, Harmonic U L1	[5]	0,1
3972	SHORT	RD	V	Average, Harmonic U L1	[6]	0,1
3973	SHORT	RD	V	Average, Harmonic U L1	[7]	0,1
3974	SHORT	RD	V	Average, Harmonic U L1	[8]	0,1
3975	SHORT	RD	V	Average, Harmonic U L1	[9]	0,1
3976	SHORT	RD	V	Average, Harmonic U L1	[10]	0,1
3977	SHORT	RD	V	Average, Harmonic U L1	[11]	0,1
3978	SHORT	RD	V	Average, Harmonic U L1	[12]	0,1
3979	SHORT	RD	V	Average, Harmonic U L1	[13]	0,1
3980	SHORT	RD	V	Average, Harmonic U L1	[14]	0,1
3981	SHORT	RD	V	Average, Harmonic U L1	[15]	0,1
3982	SHORT	RD	V	Average, Harmonic U L1	[16]	0,1
3983	SHORT	RD	V	Average, Harmonic U L1	[17]	0,1
3984	SHORT	RD	V	Average, Harmonic U L1	[18]	0,1
3985	SHORT	RD	V	Average, Harmonic U L1	[19]	0,1
3986	SHORT	RD	V	Average, Harmonic U L1	[20]	0,1
3987	SHORT	RD	V	Average, Harmonic U L1	[21]	0,1
3988	SHORT	RD	V	Average, Harmonic U L1	[22]	0,1
3989	SHORT	RD	V	Average, Harmonic U L1	[23]	0,1
3990	SHORT	RD	V	Average, Harmonic U L1	[24]	0,1
3991	SHORT	RD	V	Average, Harmonic U L1	[25]	0,1
3992	SHORT	RD	V	Average, Harmonic U L1	[26]	0,1
3993	SHORT	RD	V	Average, Harmonic U L1	[27]	0,1
3994	SHORT	RD	V	Average, Harmonic U L1	[28]	0,1
3995	SHORT	RD	V	Average, Harmonic U L1	[29]	0,1
3996	SHORT	RD	V	Average, Harmonic U L1	[30]	0,1
3997	SHORT	RD	V	Average, Harmonic U L1	[31]	0,1
3998	SHORT	RD	V	Average, Harmonic U L1	[32]	0,1
3999	SHORT	RD	V	Average, Harmonic U L1	[33]	0,1
4000	SHORT	RD	V	Average, Harmonic U L1	[34]	0,1
4001	SHORT	RD	V	Average, Harmonic U L1	[35]	0,1
4002	SHORT	RD	V	Average, Harmonic U L1	[36]	0,1
4003	SHORT	RD	V	Average, Harmonic U L1	[37]	0,1
4004	SHORT	RD	V	Average, Harmonic U L1	[38]	0,1
4005	SHORT	RD	V	Average, Harmonic U L1	[39]	0,1
4006	SHORT	RD	V	Average, Harmonic U L2	[0]	0,1
4007	SHORT	RD	V	Average, Harmonic U L2	[1]	0,1
4008	SHORT	RD	V	Average, Harmonic U L2	[2]	0,1
4009	SHORT	RD	V	Average, Harmonic U L2	[3]	0,1
4010	SHORT	RD	V	Average, Harmonic U L2	[4]	0,1
4011	SHORT	RD	V	Average, Harmonic U L2	[5]	0,1
4012	SHORT	RD	V	Average, Harmonic U L2	[6]	0,1
4013	SHORT	RD	V	Average, Harmonic U L2	[7]	0,1
4014	SHORT	RD	V	Average, Harmonic U L2	[8]	0,1
4015	SHORT	RD	V	Average, Harmonic U L2	[9]	0,1
4016	SHORT	RD	V	Average, Harmonic U L2	[10]	0,1
4017	SHORT	RD	V	Average, Harmonic U L2	[11]	0,1
4018	SHORT	RD	V	Average, Harmonic U L2	[12]	0,1
4019	SHORT	RD	V	Average, Harmonic U L2	[13]	0,1
4020	SHORT	RD	V	Average, Harmonic U L2	[14]	0,1
4021	SHORT	RD	V	Average, Harmonic U L2	[15]	0,1
4022	SHORT	RD	V	Average, Harmonic U L2	[16]	0,1
4023	SHORT	RD	V	Average, Harmonic U L2	[17]	0,1
4024	SHORT	RD	V	Average, Harmonic U L2	[18]	0,1
4025	SHORT	RD	V	Average, Harmonic U L2	[19]	0,1
4026	SHORT	RD	V	Average, Harmonic U L2	[20]	0,1
4027	SHORT	RD	V	Average, Harmonic U L2	[21]	0,1
4028	SHORT	RD	V	Average, Harmonic U L2	[22]	0,1
4029	SHORT	RD	V	Average, Harmonic U L2	[23]	0,1
4030	SHORT	RD	V	Average, Harmonic U L2	[24]	0,1
4031	SHORT	RD	V	Average, Harmonic U L2	[25]	0,1

Address	Format	RD/WR	Unit	Note	Index	Resolution
4032	SHORT	RD	V	Average, Harmonic U L2	[26]	0,1
4033	SHORT	RD	V	Average, Harmonic U L2	[27]	0,1
4034	SHORT	RD	V	Average, Harmonic U L2	[28]	0,1
4035	SHORT	RD	V	Average, Harmonic U L2	[29]	0,1
4036	SHORT	RD	V	Average, Harmonic U L2	[30]	0,1
4037	SHORT	RD	V	Average, Harmonic U L2	[31]	0,1
4038	SHORT	RD	V	Average, Harmonic U L2	[32]	0,1
4039	SHORT	RD	V	Average, Harmonic U L2	[33]	0,1
4040	SHORT	RD	V	Average, Harmonic U L2	[34]	0,1
4041	SHORT	RD	V	Average, Harmonic U L2	[35]	0,1
4042	SHORT	RD	V	Average, Harmonic U L2	[36]	0,1
4043	SHORT	RD	V	Average, Harmonic U L2	[37]	0,1
4044	SHORT	RD	V	Average, Harmonic U L2	[38]	0,1
4045	SHORT	RD	V	Average, Harmonic U L2	[39]	0,1
4046	SHORT	RD	V	Average, Harmonic U L3	[0]	0,1
4047	SHORT	RD	V	Average, Harmonic U L3	[1]	0,1
4048	SHORT	RD	V	Average, Harmonic U L3	[2]	0,1
4049	SHORT	RD	V	Average, Harmonic U L3	[3]	0,1
4050	SHORT	RD	V	Average, Harmonic U L3	[4]	0,1
4051	SHORT	RD	V	Average, Harmonic U L3	[5]	0,1
4052	SHORT	RD	V	Average, Harmonic U L3	[6]	0,1
4053	SHORT	RD	V	Average, Harmonic U L3	[7]	0,1
4054	SHORT	RD	V	Average, Harmonic U L3	[8]	0,1
4055	SHORT	RD	V	Average, Harmonic U L3	[9]	0,1
4056	SHORT	RD	V	Average, Harmonic U L3	[10]	0,1
4057	SHORT	RD	V	Average, Harmonic U L3	[11]	0,1
4058	SHORT	RD	V	Average, Harmonic U L3	[12]	0,1
4059	SHORT	RD	V	Average, Harmonic U L3	[13]	0,1
4060	SHORT	RD	V	Average, Harmonic U L3	[14]	0,1
4061	SHORT	RD	V	Average, Harmonic U L3	[15]	0,1
4062	SHORT	RD	V	Average, Harmonic U L3	[16]	0,1
4063	SHORT	RD	V	Average, Harmonic U L3	[17]	0,1
4064	SHORT	RD	V	Average, Harmonic U L3	[18]	0,1
4065	SHORT	RD	V	Average, Harmonic U L3	[19]	0,1
4066	SHORT	RD	V	Average, Harmonic U L3	[20]	0,1
4067	SHORT	RD	V	Average, Harmonic U L3	[21]	0,1
4068	SHORT	RD	V	Average, Harmonic U L3	[22]	0,1
4069	SHORT	RD	V	Average, Harmonic U L3	[23]	0,1
4070	SHORT	RD	V	Average, Harmonic U L3	[24]	0,1
4071	SHORT	RD	V	Average, Harmonic U L3	[25]	0,1
4072	SHORT	RD	V	Average, Harmonic U L3	[26]	0,1
4073	SHORT	RD	V	Average, Harmonic U L3	[27]	0,1
4074	SHORT	RD	V	Average, Harmonic U L3	[28]	0,1
4075	SHORT	RD	V	Average, Harmonic U L3	[29]	0,1
4076	SHORT	RD	V	Average, Harmonic U L3	[30]	0,1
4077	SHORT	RD	V	Average, Harmonic U L3	[31]	0,1
4078	SHORT	RD	V	Average, Harmonic U L3	[32]	0,1
4079	SHORT	RD	V	Average, Harmonic U L3	[33]	0,1
4080	SHORT	RD	V	Average, Harmonic U L3	[34]	0,1
4081	SHORT	RD	V	Average, Harmonic U L3	[35]	0,1
4082	SHORT	RD	V	Average, Harmonic U L3	[36]	0,1
4083	SHORT	RD	V	Average, Harmonic U L3	[37]	0,1
4084	SHORT	RD	V	Average, Harmonic U L3	[38]	0,1
4085	SHORT	RD	V	Average, Harmonic U L3	[39]	0,1
4086	SHORT	RD	V	Average, Harmonic U L1-L2	[0]	0,1
4087	SHORT	RD	V	Average, Harmonic U L1-L2	[1]	0,1
4088	SHORT	RD	V	Average, Harmonic U L1-L2	[2]	0,1
4089	SHORT	RD	V	Average, Harmonic U L1-L2	[3]	0,1
4090	SHORT	RD	V	Average, Harmonic U L1-L2	[4]	0,1
4091	SHORT	RD	V	Average, Harmonic U L1-L2	[5]	0,1
4092	SHORT	RD	V	Average, Harmonic U L1-L2	[6]	0,1
4093	SHORT	RD	V	Average, Harmonic U L1-L2	[7]	0,1
4094	SHORT	RD	V	Average, Harmonic U L1-L2	[8]	0,1
4095	SHORT	RD	V	Average, Harmonic U L1-L2	[9]	0,1
4096	SHORT	RD	V	Average, Harmonic U L1-L2	[10]	0,1
4097	SHORT	RD	V	Average, Harmonic U L1-L2	[11]	0,1

Address	Format	RD/WR	Unit	Note	Index	Resolution
4098	SHORT	RD	V	Average, Harmonic U L1-L2	[12]	0,1
4099	SHORT	RD	V	Average, Harmonic U L1-L2	[13]	0,1
4100	SHORT	RD	V	Average, Harmonic U L1-L2	[14]	0,1
4101	SHORT	RD	V	Average, Harmonic U L1-L2	[15]	0,1
4102	SHORT	RD	V	Average, Harmonic U L1-L2	[16]	0,1
4103	SHORT	RD	V	Average, Harmonic U L1-L2	[17]	0,1
4104	SHORT	RD	V	Average, Harmonic U L1-L2	[18]	0,1
4105	SHORT	RD	V	Average, Harmonic U L1-L2	[19]	0,1
4106	SHORT	RD	V	Average, Harmonic U L1-L2	[20]	0,1
4107	SHORT	RD	V	Average, Harmonic U L1-L2	[21]	0,1
4108	SHORT	RD	V	Average, Harmonic U L1-L2	[22]	0,1
4109	SHORT	RD	V	Average, Harmonic U L1-L2	[23]	0,1
4110	SHORT	RD	V	Average, Harmonic U L1-L2	[24]	0,1
4111	SHORT	RD	V	Average, Harmonic U L1-L2	[25]	0,1
4112	SHORT	RD	V	Average, Harmonic U L1-L2	[26]	0,1
4113	SHORT	RD	V	Average, Harmonic U L1-L2	[27]	0,1
4114	SHORT	RD	V	Average, Harmonic U L1-L2	[28]	0,1
4115	SHORT	RD	V	Average, Harmonic U L1-L2	[29]	0,1
4116	SHORT	RD	V	Average, Harmonic U L1-L2	[30]	0,1
4117	SHORT	RD	V	Average, Harmonic U L1-L2	[31]	0,1
4118	SHORT	RD	V	Average, Harmonic U L1-L2	[32]	0,1
4119	SHORT	RD	V	Average, Harmonic U L1-L2	[33]	0,1
4120	SHORT	RD	V	Average, Harmonic U L1-L2	[34]	0,1
4121	SHORT	RD	V	Average, Harmonic U L1-L2	[35]	0,1
4122	SHORT	RD	V	Average, Harmonic U L1-L2	[36]	0,1
4123	SHORT	RD	V	Average, Harmonic U L1-L2	[37]	0,1
4124	SHORT	RD	V	Average, Harmonic U L1-L2	[38]	0,1
4125	SHORT	RD	V	Average, Harmonic U L1-L2	[39]	0,1
4126	SHORT	RD	V	Average, Harmonic U L2-L3	[0]	0,1
4127	SHORT	RD	V	Average, Harmonic U L2-L3	[1]	0,1
4128	SHORT	RD	V	Average, Harmonic U L2-L3	[2]	0,1
4129	SHORT	RD	V	Average, Harmonic U L2-L3	[3]	0,1
4130	SHORT	RD	V	Average, Harmonic U L2-L3	[4]	0,1
4131	SHORT	RD	V	Average, Harmonic U L2-L3	[5]	0,1
4132	SHORT	RD	V	Average, Harmonic U L2-L3	[6]	0,1
4133	SHORT	RD	V	Average, Harmonic U L2-L3	[7]	0,1
4134	SHORT	RD	V	Average, Harmonic U L2-L3	[8]	0,1
4135	SHORT	RD	V	Average, Harmonic U L2-L3	[9]	0,1
4136	SHORT	RD	V	Average, Harmonic U L2-L3	[10]	0,1
4137	SHORT	RD	V	Average, Harmonic U L2-L3	[11]	0,1
4138	SHORT	RD	V	Average, Harmonic U L2-L3	[12]	0,1
4139	SHORT	RD	V	Average, Harmonic U L2-L3	[13]	0,1
4140	SHORT	RD	V	Average, Harmonic U L2-L3	[14]	0,1
4141	SHORT	RD	V	Average, Harmonic U L2-L3	[15]	0,1
4142	SHORT	RD	V	Average, Harmonic U L2-L3	[16]	0,1
4143	SHORT	RD	V	Average, Harmonic U L2-L3	[17]	0,1
4144	SHORT	RD	V	Average, Harmonic U L2-L3	[18]	0,1
4145	SHORT	RD	V	Average, Harmonic U L2-L3	[19]	0,1
4146	SHORT	RD	V	Average, Harmonic U L2-L3	[20]	0,1
4147	SHORT	RD	V	Average, Harmonic U L2-L3	[21]	0,1
4148	SHORT	RD	V	Average, Harmonic U L2-L3	[22]	0,1
4149	SHORT	RD	V	Average, Harmonic U L2-L3	[23]	0,1
4150	SHORT	RD	V	Average, Harmonic U L2-L3	[24]	0,1
4151	SHORT	RD	V	Average, Harmonic U L2-L3	[25]	0,1
4152	SHORT	RD	V	Average, Harmonic U L2-L3	[26]	0,1
4153	SHORT	RD	V	Average, Harmonic U L2-L3	[27]	0,1
4154	SHORT	RD	V	Average, Harmonic U L2-L3	[28]	0,1
4155	SHORT	RD	V	Average, Harmonic U L2-L3	[29]	0,1
4156	SHORT	RD	V	Average, Harmonic U L2-L3	[30]	0,1
4157	SHORT	RD	V	Average, Harmonic U L2-L3	[31]	0,1
4158	SHORT	RD	V	Average, Harmonic U L2-L3	[32]	0,1
4159	SHORT	RD	V	Average, Harmonic U L2-L3	[33]	0,1
4160	SHORT	RD	V	Average, Harmonic U L2-L3	[34]	0,1
4161	SHORT	RD	V	Average, Harmonic U L2-L3	[35]	0,1
4162	SHORT	RD	V	Average, Harmonic U L2-L3	[36]	0,1
4163	SHORT	RD	V	Average, Harmonic U L2-L3	[37]	0,1

Address	Format	RD/WR	Unit	Note	Index	Resolution
4164	SHORT	RD	V	Average, Harmonic U L2-L3	[38]	0,1
4165	SHORT	RD	V	Average, Harmonic U L2-L3	[39]	0,1
4166	SHORT	RD	V	Average, Harmonic U L3-L1	[0]	0,1
4167	SHORT	RD	V	Average, Harmonic U L3-L1	[1]	0,1
4168	SHORT	RD	V	Average, Harmonic U L3-L1	[2]	0,1
4169	SHORT	RD	V	Average, Harmonic U L3-L1	[3]	0,1
4170	SHORT	RD	V	Average, Harmonic U L3-L1	[4]	0,1
4171	SHORT	RD	V	Average, Harmonic U L3-L1	[5]	0,1
4172	SHORT	RD	V	Average, Harmonic U L3-L1	[6]	0,1
4173	SHORT	RD	V	Average, Harmonic U L3-L1	[7]	0,1
4174	SHORT	RD	V	Average, Harmonic U L3-L1	[8]	0,1
4175	SHORT	RD	V	Average, Harmonic U L3-L1	[9]	0,1
4176	SHORT	RD	V	Average, Harmonic U L3-L1	[10]	0,1
4177	SHORT	RD	V	Average, Harmonic U L3-L1	[11]	0,1
4178	SHORT	RD	V	Average, Harmonic U L3-L1	[12]	0,1
4179	SHORT	RD	V	Average, Harmonic U L3-L1	[13]	0,1
4180	SHORT	RD	V	Average, Harmonic U L3-L1	[14]	0,1
4181	SHORT	RD	V	Average, Harmonic U L3-L1	[15]	0,1
4182	SHORT	RD	V	Average, Harmonic U L3-L1	[16]	0,1
4183	SHORT	RD	V	Average, Harmonic U L3-L1	[17]	0,1
4184	SHORT	RD	V	Average, Harmonic U L3-L1	[18]	0,1
4185	SHORT	RD	V	Average, Harmonic U L3-L1	[19]	0,1
4186	SHORT	RD	V	Average, Harmonic U L3-L1	[20]	0,1
4187	SHORT	RD	V	Average, Harmonic U L3-L1	[21]	0,1
4188	SHORT	RD	V	Average, Harmonic U L3-L1	[22]	0,1
4189	SHORT	RD	V	Average, Harmonic U L3-L1	[23]	0,1
4190	SHORT	RD	V	Average, Harmonic U L3-L1	[24]	0,1
4191	SHORT	RD	V	Average, Harmonic U L3-L1	[25]	0,1
4192	SHORT	RD	V	Average, Harmonic U L3-L1	[26]	0,1
4193	SHORT	RD	V	Average, Harmonic U L3-L1	[27]	0,1
4194	SHORT	RD	V	Average, Harmonic U L3-L1	[28]	0,1
4195	SHORT	RD	V	Average, Harmonic U L3-L1	[29]	0,1
4196	SHORT	RD	V	Average, Harmonic U L3-L1	[30]	0,1
4197	SHORT	RD	V	Average, Harmonic U L3-L1	[31]	0,1
4198	SHORT	RD	V	Average, Harmonic U L3-L1	[32]	0,1
4199	SHORT	RD	V	Average, Harmonic U L3-L1	[33]	0,1
4200	SHORT	RD	V	Average, Harmonic U L3-L1	[34]	0,1
4201	SHORT	RD	V	Average, Harmonic U L3-L1	[35]	0,1
4202	SHORT	RD	V	Average, Harmonic U L3-L1	[36]	0,1
4203	SHORT	RD	V	Average, Harmonic U L3-L1	[37]	0,1
4204	SHORT	RD	V	Average, Harmonic U L3-L1	[38]	0,1
4205	SHORT	RD	V	Average, Harmonic U L3-L1	[39]	0,1
4226	SHORT	RD	mA	Average, Harmonic I L1	[0]	1
4227	SHORT	RD	mA	Average, Harmonic I L1	[1]	1
4228	SHORT	RD	mA	Average, Harmonic I L1	[2]	1
4229	SHORT	RD	mA	Average, Harmonic I L1	[3]	1
4230	SHORT	RD	mA	Average, Harmonic I L1	[4]	1
4231	SHORT	RD	mA	Average, Harmonic I L1	[5]	1
4232	SHORT	RD	mA	Average, Harmonic I L1	[6]	1
4233	SHORT	RD	mA	Average, Harmonic I L1	[7]	1
4234	SHORT	RD	mA	Average, Harmonic I L1	[8]	1
4235	SHORT	RD	mA	Average, Harmonic I L1	[9]	1
4236	SHORT	RD	mA	Average, Harmonic I L1	[10]	1
4237	SHORT	RD	mA	Average, Harmonic I L1	[11]	1
4238	SHORT	RD	mA	Average, Harmonic I L1	[12]	1
4239	SHORT	RD	mA	Average, Harmonic I L1	[13]	1
4240	SHORT	RD	mA	Average, Harmonic I L1	[14]	1
4241	SHORT	RD	mA	Average, Harmonic I L1	[15]	1
4242	SHORT	RD	mA	Average, Harmonic I L1	[16]	1
4243	SHORT	RD	mA	Average, Harmonic I L1	[17]	1
4244	SHORT	RD	mA	Average, Harmonic I L1	[18]	1
4245	SHORT	RD	mA	Average, Harmonic I L1	[19]	1
4246	SHORT	RD	mA	Average, Harmonic I L1	[20]	1
4247	SHORT	RD	mA	Average, Harmonic I L1	[21]	1
4248	SHORT	RD	mA	Average, Harmonic I L1	[22]	1
4249	SHORT	RD	mA	Average, Harmonic I L1	[23]	1

Address	Format	RD/WR	Unit	Note	Index	Resolution
4250	SHORT	RD	mA	Average, Harmonic I L1	[24]	1
4251	SHORT	RD	mA	Average, Harmonic I L1	[25]	1
4252	SHORT	RD	mA	Average, Harmonic I L1	[26]	1
4253	SHORT	RD	mA	Average, Harmonic I L1	[27]	1
4254	SHORT	RD	mA	Average, Harmonic I L1	[28]	1
4255	SHORT	RD	mA	Average, Harmonic I L1	[29]	1
4256	SHORT	RD	mA	Average, Harmonic I L1	[30]	1
4257	SHORT	RD	mA	Average, Harmonic I L1	[31]	1
4258	SHORT	RD	mA	Average, Harmonic I L1	[32]	1
4259	SHORT	RD	mA	Average, Harmonic I L1	[33]	1
4260	SHORT	RD	mA	Average, Harmonic I L1	[34]	1
4261	SHORT	RD	mA	Average, Harmonic I L1	[35]	1
4262	SHORT	RD	mA	Average, Harmonic I L1	[36]	1
4263	SHORT	RD	mA	Average, Harmonic I L1	[37]	1
4264	SHORT	RD	mA	Average, Harmonic I L1	[38]	1
4265	SHORT	RD	mA	Average, Harmonic I L1	[39]	1
4266	SHORT	RD	mA	Average, Harmonic I L2	[0]	1
4267	SHORT	RD	mA	Average, Harmonic I L2	[1]	1
4268	SHORT	RD	mA	Average, Harmonic I L2	[2]	1
4269	SHORT	RD	mA	Average, Harmonic I L2	[3]	1
4270	SHORT	RD	mA	Average, Harmonic I L2	[4]	1
4271	SHORT	RD	mA	Average, Harmonic I L2	[5]	1
4272	SHORT	RD	mA	Average, Harmonic I L2	[6]	1
4273	SHORT	RD	mA	Average, Harmonic I L2	[7]	1
4274	SHORT	RD	mA	Average, Harmonic I L2	[8]	1
4275	SHORT	RD	mA	Average, Harmonic I L2	[9]	1
4276	SHORT	RD	mA	Average, Harmonic I L2	[10]	1
4277	SHORT	RD	mA	Average, Harmonic I L2	[11]	1
4278	SHORT	RD	mA	Average, Harmonic I L2	[12]	1
4279	SHORT	RD	mA	Average, Harmonic I L2	[13]	1
4280	SHORT	RD	mA	Average, Harmonic I L2	[14]	1
4281	SHORT	RD	mA	Average, Harmonic I L2	[15]	1
4282	SHORT	RD	mA	Average, Harmonic I L2	[16]	1
4283	SHORT	RD	mA	Average, Harmonic I L2	[17]	1
4284	SHORT	RD	mA	Average, Harmonic I L2	[18]	1
4285	SHORT	RD	mA	Average, Harmonic I L2	[19]	1
4286	SHORT	RD	mA	Average, Harmonic I L2	[20]	1
4287	SHORT	RD	mA	Average, Harmonic I L2	[21]	1
4288	SHORT	RD	mA	Average, Harmonic I L2	[22]	1
4289	SHORT	RD	mA	Average, Harmonic I L2	[23]	1
4290	SHORT	RD	mA	Average, Harmonic I L2	[24]	1
4291	SHORT	RD	mA	Average, Harmonic I L2	[25]	1
4292	SHORT	RD	mA	Average, Harmonic I L2	[26]	1
4293	SHORT	RD	mA	Average, Harmonic I L2	[27]	1
4294	SHORT	RD	mA	Average, Harmonic I L2	[28]	1
4295	SHORT	RD	mA	Average, Harmonic I L2	[29]	1
4296	SHORT	RD	mA	Average, Harmonic I L2	[30]	1
4297	SHORT	RD	mA	Average, Harmonic I L2	[31]	1
4298	SHORT	RD	mA	Average, Harmonic I L2	[32]	1
4299	SHORT	RD	mA	Average, Harmonic I L2	[33]	1
4300	SHORT	RD	mA	Average, Harmonic I L2	[34]	1
4301	SHORT	RD	mA	Average, Harmonic I L2	[35]	1
4302	SHORT	RD	mA	Average, Harmonic I L2	[36]	1
4303	SHORT	RD	mA	Average, Harmonic I L2	[37]	1
4304	SHORT	RD	mA	Average, Harmonic I L2	[38]	1
4305	SHORT	RD	mA	Average, Harmonic I L2	[39]	1
4306	SHORT	RD	mA	Average, Harmonic I L3	[0]	1
4307	SHORT	RD	mA	Average, Harmonic I L3	[1]	1
4308	SHORT	RD	mA	Average, Harmonic I L3	[2]	1
4309	SHORT	RD	mA	Average, Harmonic I L3	[3]	1
4310	SHORT	RD	mA	Average, Harmonic I L3	[4]	1
4311	SHORT	RD	mA	Average, Harmonic I L3	[5]	1
4312	SHORT	RD	mA	Average, Harmonic I L3	[6]	1
4313	SHORT	RD	mA	Average, Harmonic I L3	[7]	1
4314	SHORT	RD	mA	Average, Harmonic I L3	[8]	1
4315	SHORT	RD	mA	Average, Harmonic I L3	[9]	1

Address	Format	RD/WR	Unit	Note	Index	Resolution
4316	SHORT	RD	mA	Average, Harmonic I L3	[10]	1
4317	SHORT	RD	mA	Average, Harmonic I L3	[11]	1
4318	SHORT	RD	mA	Average, Harmonic I L3	[12]	1
4319	SHORT	RD	mA	Average, Harmonic I L3	[13]	1
4320	SHORT	RD	mA	Average, Harmonic I L3	[14]	1
4321	SHORT	RD	mA	Average, Harmonic I L3	[15]	1
4322	SHORT	RD	mA	Average, Harmonic I L3	[16]	1
4323	SHORT	RD	mA	Average, Harmonic I L3	[17]	1
4324	SHORT	RD	mA	Average, Harmonic I L3	[18]	1
4325	SHORT	RD	mA	Average, Harmonic I L3	[19]	1
4326	SHORT	RD	mA	Average, Harmonic I L3	[20]	1
4327	SHORT	RD	mA	Average, Harmonic I L3	[21]	1
4328	SHORT	RD	mA	Average, Harmonic I L3	[22]	1
4329	SHORT	RD	mA	Average, Harmonic I L3	[23]	1
4330	SHORT	RD	mA	Average, Harmonic I L3	[24]	1
4331	SHORT	RD	mA	Average, Harmonic I L3	[25]	1
4332	SHORT	RD	mA	Average, Harmonic I L3	[26]	1
4333	SHORT	RD	mA	Average, Harmonic I L3	[27]	1
4334	SHORT	RD	mA	Average, Harmonic I L3	[28]	1
4335	SHORT	RD	mA	Average, Harmonic I L3	[29]	1
4336	SHORT	RD	mA	Average, Harmonic I L3	[30]	1
4337	SHORT	RD	mA	Average, Harmonic I L3	[31]	1
4338	SHORT	RD	mA	Average, Harmonic I L3	[32]	1
4339	SHORT	RD	mA	Average, Harmonic I L3	[33]	1
4340	SHORT	RD	mA	Average, Harmonic I L3	[34]	1
4341	SHORT	RD	mA	Average, Harmonic I L3	[35]	1
4342	SHORT	RD	mA	Average, Harmonic I L3	[36]	1
4343	SHORT	RD	mA	Average, Harmonic I L3	[37]	1
4344	SHORT	RD	mA	Average, Harmonic I L3	[38]	1
4345	SHORT	RD	mA	Average, Harmonic I L3	[39]	1

Maximum values, type float, fourier analysis

Address	Format	RD/WR	Unit	Note	Index
2598	FLOAT	RD/WR	V	Maximum, Harmonic U L1	[0]
2600	FLOAT	RD/WR	V	Maximum, Harmonic U L1	[1]
2602	FLOAT	RD/WR	V	Maximum, Harmonic U L1	[2]
2604	FLOAT	RD/WR	V	Maximum, Harmonic U L1	[3]
2606	FLOAT	RD/WR	V	Maximum, Harmonic U L1	[4]
2608	FLOAT	RD/WR	V	Maximum, Harmonic U L1	[5]
2610	FLOAT	RD/WR	V	Maximum, Harmonic U L1	[6]
2612	FLOAT	RD/WR	V	Maximum, Harmonic U L1	[7]
2614	FLOAT	RD/WR	V	Maximum, Harmonic U L1	[8]
2616	FLOAT	RD/WR	V	Maximum, Harmonic U L1	[9]
2618	FLOAT	RD/WR	V	Maximum, Harmonic U L1	[10]
2620	FLOAT	RD/WR	V	Maximum, Harmonic U L1	[11]
2622	FLOAT	RD/WR	V	Maximum, Harmonic U L1	[12]
2624	FLOAT	RD/WR	V	Maximum, Harmonic U L1	[13]
2626	FLOAT	RD/WR	V	Maximum, Harmonic U L1	[14]
2628	FLOAT	RD/WR	V	Maximum, Harmonic U L1	[15]
2630	FLOAT	RD/WR	V	Maximum, Harmonic U L1	[16]
2632	FLOAT	RD/WR	V	Maximum, Harmonic U L1	[17]
2634	FLOAT	RD/WR	V	Maximum, Harmonic U L1	[18]
2636	FLOAT	RD/WR	V	Maximum, Harmonic U L1	[19]
2638	FLOAT	RD/WR	V	Maximum, Harmonic U L1	[20]
2640	FLOAT	RD/WR	V	Maximum, Harmonic U L1	[21]
2642	FLOAT	RD/WR	V	Maximum, Harmonic U L1	[22]
2644	FLOAT	RD/WR	V	Maximum, Harmonic U L1	[23]
2646	FLOAT	RD/WR	V	Maximum, Harmonic U L1	[24]
2648	FLOAT	RD/WR	V	Maximum, Harmonic U L1	[25]
2650	FLOAT	RD/WR	V	Maximum, Harmonic U L1	[26]
2652	FLOAT	RD/WR	V	Maximum, Harmonic U L1	[27]
2654	FLOAT	RD/WR	V	Maximum, Harmonic U L1	[28]
2656	FLOAT	RD/WR	V	Maximum, Harmonic U L1	[29]
2658	FLOAT	RD/WR	V	Maximum, Harmonic U L1	[30]
2660	FLOAT	RD/WR	V	Maximum, Harmonic U L1	[31]
2662	FLOAT	RD/WR	V	Maximum, Harmonic U L1	[32]
2664	FLOAT	RD/WR	V	Maximum, Harmonic U L1	[33]
2666	FLOAT	RD/WR	V	Maximum, Harmonic U L1	[34]
2668	FLOAT	RD/WR	V	Maximum, Harmonic U L1	[35]
2670	FLOAT	RD/WR	V	Maximum, Harmonic U L1	[36]
2672	FLOAT	RD/WR	V	Maximum, Harmonic U L1	[37]
2674	FLOAT	RD/WR	V	Maximum, Harmonic U L1	[38]
2676	FLOAT	RD/WR	V	Maximum, Harmonic U L1	[39]
2678	FLOAT	RD/WR	V	Maximum, Harmonic U L2	[0]
2680	FLOAT	RD/WR	V	Maximum, Harmonic U L2	[1]
2682	FLOAT	RD/WR	V	Maximum, Harmonic U L2	[2]
2684	FLOAT	RD/WR	V	Maximum, Harmonic U L2	[3]
2686	FLOAT	RD/WR	V	Maximum, Harmonic U L2	[4]
2688	FLOAT	RD/WR	V	Maximum, Harmonic U L2	[5]
2690	FLOAT	RD/WR	V	Maximum, Harmonic U L2	[6]
2692	FLOAT	RD/WR	V	Maximum, Harmonic U L2	[7]
2694	FLOAT	RD/WR	V	Maximum, Harmonic U L2	[8]
2696	FLOAT	RD/WR	V	Maximum, Harmonic U L2	[9]
2698	FLOAT	RD/WR	V	Maximum, Harmonic U L2	[10]
2700	FLOAT	RD/WR	V	Maximum, Harmonic U L2	[11]
2702	FLOAT	RD/WR	V	Maximum, Harmonic U L2	[12]
2704	FLOAT	RD/WR	V	Maximum, Harmonic U L2	[13]
2706	FLOAT	RD/WR	V	Maximum, Harmonic U L2	[14]
2708	FLOAT	RD/WR	V	Maximum, Harmonic U L2	[15]
2710	FLOAT	RD/WR	V	Maximum, Harmonic U L2	[16]
2712	FLOAT	RD/WR	V	Maximum, Harmonic U L2	[17]
2714	FLOAT	RD/WR	V	Maximum, Harmonic U L2	[18]
2716	FLOAT	RD/WR	V	Maximum, Harmonic U L2	[19]
2718	FLOAT	RD/WR	V	Maximum, Harmonic U L2	[20]
2720	FLOAT	RD/WR	V	Maximum, Harmonic U L2	[21]
2722	FLOAT	RD/WR	V	Maximum, Harmonic U L2	[22]
2724	FLOAT	RD/WR	V	Maximum, Harmonic U L2	[23]
2726	FLOAT	RD/WR	V	Maximum, Harmonic U L2	[24]
2728	FLOAT	RD/WR	V	Maximum, Harmonic U L2	[25]

Address	Format	RD/WR	Unit	Note	Index
2730	FLOAT	RD/WR	V	Maximum, Harmonic U L2	[26]
2732	FLOAT	RD/WR	V	Maximum, Harmonic U L2	[27]
2734	FLOAT	RD/WR	V	Maximum, Harmonic U L2	[28]
2736	FLOAT	RD/WR	V	Maximum, Harmonic U L2	[29]
2738	FLOAT	RD/WR	V	Maximum, Harmonic U L2	[30]
2740	FLOAT	RD/WR	V	Maximum, Harmonic U L2	[31]
2742	FLOAT	RD/WR	V	Maximum, Harmonic U L2	[32]
2744	FLOAT	RD/WR	V	Maximum, Harmonic U L2	[33]
2746	FLOAT	RD/WR	V	Maximum, Harmonic U L2	[34]
2748	FLOAT	RD/WR	V	Maximum, Harmonic U L2	[35]
2750	FLOAT	RD/WR	V	Maximum, Harmonic U L2	[36]
2752	FLOAT	RD/WR	V	Maximum, Harmonic U L2	[37]
2754	FLOAT	RD/WR	V	Maximum, Harmonic U L2	[38]
2756	FLOAT	RD/WR	V	Maximum, Harmonic U L2	[39]
2758	FLOAT	RD/WR	V	Maximum, Harmonic U L3	[0]
2760	FLOAT	RD/WR	V	Maximum, Harmonic U L3	[1]
2762	FLOAT	RD/WR	V	Maximum, Harmonic U L3	[2]
2764	FLOAT	RD/WR	V	Maximum, Harmonic U L3	[3]
2766	FLOAT	RD/WR	V	Maximum, Harmonic U L3	[4]
2768	FLOAT	RD/WR	V	Maximum, Harmonic U L3	[5]
2770	FLOAT	RD/WR	V	Maximum, Harmonic U L3	[6]
2772	FLOAT	RD/WR	V	Maximum, Harmonic U L3	[7]
2774	FLOAT	RD/WR	V	Maximum, Harmonic U L3	[8]
2776	FLOAT	RD/WR	V	Maximum, Harmonic U L3	[9]
2778	FLOAT	RD/WR	V	Maximum, Harmonic U L3	[10]
2780	FLOAT	RD/WR	V	Maximum, Harmonic U L3	[11]
2782	FLOAT	RD/WR	V	Maximum, Harmonic U L3	[12]
2784	FLOAT	RD/WR	V	Maximum, Harmonic U L3	[13]
2786	FLOAT	RD/WR	V	Maximum, Harmonic U L3	[14]
2788	FLOAT	RD/WR	V	Maximum, Harmonic U L3	[15]
2790	FLOAT	RD/WR	V	Maximum, Harmonic U L3	[16]
2792	FLOAT	RD/WR	V	Maximum, Harmonic U L3	[17]
2794	FLOAT	RD/WR	V	Maximum, Harmonic U L3	[18]
2796	FLOAT	RD/WR	V	Maximum, Harmonic U L3	[19]
2798	FLOAT	RD/WR	V	Maximum, Harmonic U L3	[20]
2800	FLOAT	RD/WR	V	Maximum, Harmonic U L3	[21]
2802	FLOAT	RD/WR	V	Maximum, Harmonic U L3	[22]
2804	FLOAT	RD/WR	V	Maximum, Harmonic U L3	[23]
2806	FLOAT	RD/WR	V	Maximum, Harmonic U L3	[24]
2808	FLOAT	RD/WR	V	Maximum, Harmonic U L3	[25]
2810	FLOAT	RD/WR	V	Maximum, Harmonic U L3	[26]
2812	FLOAT	RD/WR	V	Maximum, Harmonic U L3	[27]
2814	FLOAT	RD/WR	V	Maximum, Harmonic U L3	[28]
2816	FLOAT	RD/WR	V	Maximum, Harmonic U L3	[29]
2818	FLOAT	RD/WR	V	Maximum, Harmonic U L3	[30]
2820	FLOAT	RD/WR	V	Maximum, Harmonic U L3	[31]
2822	FLOAT	RD/WR	V	Maximum, Harmonic U L3	[32]
2824	FLOAT	RD/WR	V	Maximum, Harmonic U L3	[33]
2826	FLOAT	RD/WR	V	Maximum, Harmonic U L3	[34]
2828	FLOAT	RD/WR	V	Maximum, Harmonic U L3	[35]
2830	FLOAT	RD/WR	V	Maximum, Harmonic U L3	[36]
2832	FLOAT	RD/WR	V	Maximum, Harmonic U L3	[37]
2834	FLOAT	RD/WR	V	Maximum, Harmonic U L3	[38]
2836	FLOAT	RD/WR	V	Maximum, Harmonic U L3	[39]
2838	FLOAT	RD/WR	V	Maximum, Harmonic U L1-L2	[0]
2840	FLOAT	RD/WR	V	Maximum, Harmonic U L1-L2	[1]
2842	FLOAT	RD/WR	V	Maximum, Harmonic U L1-L2	[2]
2844	FLOAT	RD/WR	V	Maximum, Harmonic U L1-L2	[3]
2846	FLOAT	RD/WR	V	Maximum, Harmonic U L1-L2	[4]
2848	FLOAT	RD/WR	V	Maximum, Harmonic U L1-L2	[5]
2850	FLOAT	RD/WR	V	Maximum, Harmonic U L1-L2	[6]
2852	FLOAT	RD/WR	V	Maximum, Harmonic U L1-L2	[7]
2854	FLOAT	RD/WR	V	Maximum, Harmonic U L1-L2	[8]
2856	FLOAT	RD/WR	V	Maximum, Harmonic U L1-L2	[9]
2858	FLOAT	RD/WR	V	Maximum, Harmonic U L1-L2	[10]
2860	FLOAT	RD/WR	V	Maximum, Harmonic U L1-L2	[11]

Address	Format	RD/WR	Unit	Note	Index
2862	FLOAT	RD/WR	V	Maximum, Harmonic U L1-L2	[12]
2864	FLOAT	RD/WR	V	Maximum, Harmonic U L1-L2	[13]
2866	FLOAT	RD/WR	V	Maximum, Harmonic U L1-L2	[14]
2868	FLOAT	RD/WR	V	Maximum, Harmonic U L1-L2	[15]
2870	FLOAT	RD/WR	V	Maximum, Harmonic U L1-L2	[16]
2872	FLOAT	RD/WR	V	Maximum, Harmonic U L1-L2	[17]
2874	FLOAT	RD/WR	V	Maximum, Harmonic U L1-L2	[18]
2876	FLOAT	RD/WR	V	Maximum, Harmonic U L1-L2	[19]
2878	FLOAT	RD/WR	V	Maximum, Harmonic U L1-L2	[20]
2880	FLOAT	RD/WR	V	Maximum, Harmonic U L1-L2	[21]
2882	FLOAT	RD/WR	V	Maximum, Harmonic U L1-L2	[22]
2884	FLOAT	RD/WR	V	Maximum, Harmonic U L1-L2	[23]
2886	FLOAT	RD/WR	V	Maximum, Harmonic U L1-L2	[24]
2888	FLOAT	RD/WR	V	Maximum, Harmonic U L1-L2	[25]
2890	FLOAT	RD/WR	V	Maximum, Harmonic U L1-L2	[26]
2892	FLOAT	RD/WR	V	Maximum, Harmonic U L1-L2	[27]
2894	FLOAT	RD/WR	V	Maximum, Harmonic U L1-L2	[28]
2896	FLOAT	RD/WR	V	Maximum, Harmonic U L1-L2	[29]
2898	FLOAT	RD/WR	V	Maximum, Harmonic U L1-L2	[30]
2900	FLOAT	RD/WR	V	Maximum, Harmonic U L1-L2	[31]
2902	FLOAT	RD/WR	V	Maximum, Harmonic U L1-L2	[32]
2904	FLOAT	RD/WR	V	Maximum, Harmonic U L1-L2	[33]
2906	FLOAT	RD/WR	V	Maximum, Harmonic U L1-L2	[34]
2908	FLOAT	RD/WR	V	Maximum, Harmonic U L1-L2	[35]
2910	FLOAT	RD/WR	V	Maximum, Harmonic U L1-L2	[36]
2912	FLOAT	RD/WR	V	Maximum, Harmonic U L1-L2	[37]
2914	FLOAT	RD/WR	V	Maximum, Harmonic U L1-L2	[38]
2916	FLOAT	RD/WR	V	Maximum, Harmonic U L1-L2	[39]
2918	FLOAT	RD/WR	V	Maximum, Harmonic U L2-L3	[0]
2920	FLOAT	RD/WR	V	Maximum, Harmonic U L2-L3	[1]
2922	FLOAT	RD/WR	V	Maximum, Harmonic U L2-L3	[2]
2924	FLOAT	RD/WR	V	Maximum, Harmonic U L2-L3	[3]
2926	FLOAT	RD/WR	V	Maximum, Harmonic U L2-L3	[4]
2928	FLOAT	RD/WR	V	Maximum, Harmonic U L2-L3	[5]
2930	FLOAT	RD/WR	V	Maximum, Harmonic U L2-L3	[6]
2932	FLOAT	RD/WR	V	Maximum, Harmonic U L2-L3	[7]
2934	FLOAT	RD/WR	V	Maximum, Harmonic U L2-L3	[8]
2936	FLOAT	RD/WR	V	Maximum, Harmonic U L2-L3	[9]
2938	FLOAT	RD/WR	V	Maximum, Harmonic U L2-L3	[10]
2940	FLOAT	RD/WR	V	Maximum, Harmonic U L2-L3	[11]
2942	FLOAT	RD/WR	V	Maximum, Harmonic U L2-L3	[12]
2944	FLOAT	RD/WR	V	Maximum, Harmonic U L2-L3	[13]
2946	FLOAT	RD/WR	V	Maximum, Harmonic U L2-L3	[14]
2948	FLOAT	RD/WR	V	Maximum, Harmonic U L2-L3	[15]
2950	FLOAT	RD/WR	V	Maximum, Harmonic U L2-L3	[16]
2952	FLOAT	RD/WR	V	Maximum, Harmonic U L2-L3	[17]
2954	FLOAT	RD/WR	V	Maximum, Harmonic U L2-L3	[18]
2956	FLOAT	RD/WR	V	Maximum, Harmonic U L2-L3	[19]
2958	FLOAT	RD/WR	V	Maximum, Harmonic U L2-L3	[20]
2960	FLOAT	RD/WR	V	Maximum, Harmonic U L2-L3	[21]
2962	FLOAT	RD/WR	V	Maximum, Harmonic U L2-L3	[22]
2964	FLOAT	RD/WR	V	Maximum, Harmonic U L2-L3	[23]
2966	FLOAT	RD/WR	V	Maximum, Harmonic U L2-L3	[24]
2968	FLOAT	RD/WR	V	Maximum, Harmonic U L2-L3	[25]
2970	FLOAT	RD/WR	V	Maximum, Harmonic U L2-L3	[26]
2972	FLOAT	RD/WR	V	Maximum, Harmonic U L2-L3	[27]
2974	FLOAT	RD/WR	V	Maximum, Harmonic U L2-L3	[28]
2976	FLOAT	RD/WR	V	Maximum, Harmonic U L2-L3	[29]
2978	FLOAT	RD/WR	V	Maximum, Harmonic U L2-L3	[30]
2980	FLOAT	RD/WR	V	Maximum, Harmonic U L2-L3	[31]
2982	FLOAT	RD/WR	V	Maximum, Harmonic U L2-L3	[32]
2984	FLOAT	RD/WR	V	Maximum, Harmonic U L2-L3	[33]
2986	FLOAT	RD/WR	V	Maximum, Harmonic U L2-L3	[34]
2988	FLOAT	RD/WR	V	Maximum, Harmonic U L2-L3	[35]
2990	FLOAT	RD/WR	V	Maximum, Harmonic U L2-L3	[36]
2992	FLOAT	RD/WR	V	Maximum, Harmonic U L2-L3	[37]

Address	Format	RD/WR	Unit	Note	Index
2994	FLOAT	RD/WR	V	Maximum, Harmonic U L2-L3	[38]
2996	FLOAT	RD/WR	V	Maximum, Harmonic U L2-L3	[39]
2998	FLOAT	RD/WR	V	Maximum, Harmonic U L3-L1	[0]
3000	FLOAT	RD/WR	V	Maximum, Harmonic U L3-L1	[1]
3002	FLOAT	RD/WR	V	Maximum, Harmonic U L3-L1	[2]
3004	FLOAT	RD/WR	V	Maximum, Harmonic U L3-L1	[3]
3006	FLOAT	RD/WR	V	Maximum, Harmonic U L3-L1	[4]
3008	FLOAT	RD/WR	V	Maximum, Harmonic U L3-L1	[5]
3010	FLOAT	RD/WR	V	Maximum, Harmonic U L3-L1	[6]
3012	FLOAT	RD/WR	V	Maximum, Harmonic U L3-L1	[7]
3014	FLOAT	RD/WR	V	Maximum, Harmonic U L3-L1	[8]
3016	FLOAT	RD/WR	V	Maximum, Harmonic U L3-L1	[9]
3018	FLOAT	RD/WR	V	Maximum, Harmonic U L3-L1	[10]
3020	FLOAT	RD/WR	V	Maximum, Harmonic U L3-L1	[11]
3022	FLOAT	RD/WR	V	Maximum, Harmonic U L3-L1	[12]
3024	FLOAT	RD/WR	V	Maximum, Harmonic U L3-L1	[13]
3026	FLOAT	RD/WR	V	Maximum, Harmonic U L3-L1	[14]
3028	FLOAT	RD/WR	V	Maximum, Harmonic U L3-L1	[15]
3030	FLOAT	RD/WR	V	Maximum, Harmonic U L3-L1	[16]
3032	FLOAT	RD/WR	V	Maximum, Harmonic U L3-L1	[17]
3034	FLOAT	RD/WR	V	Maximum, Harmonic U L3-L1	[18]
3036	FLOAT	RD/WR	V	Maximum, Harmonic U L3-L1	[19]
3038	FLOAT	RD/WR	V	Maximum, Harmonic U L3-L1	[20]
3040	FLOAT	RD/WR	V	Maximum, Harmonic U L3-L1	[21]
3042	FLOAT	RD/WR	V	Maximum, Harmonic U L3-L1	[22]
3044	FLOAT	RD/WR	V	Maximum, Harmonic U L3-L1	[23]
3046	FLOAT	RD/WR	V	Maximum, Harmonic U L3-L1	[24]
3048	FLOAT	RD/WR	V	Maximum, Harmonic U L3-L1	[25]
3050	FLOAT	RD/WR	V	Maximum, Harmonic U L3-L1	[26]
3052	FLOAT	RD/WR	V	Maximum, Harmonic U L3-L1	[27]
3054	FLOAT	RD/WR	V	Maximum, Harmonic U L3-L1	[28]
3056	FLOAT	RD/WR	V	Maximum, Harmonic U L3-L1	[29]
3058	FLOAT	RD/WR	V	Maximum, Harmonic U L3-L1	[30]
3060	FLOAT	RD/WR	V	Maximum, Harmonic U L3-L1	[31]
3062	FLOAT	RD/WR	V	Maximum, Harmonic U L3-L1	[32]
3064	FLOAT	RD/WR	V	Maximum, Harmonic U L3-L1	[33]
3066	FLOAT	RD/WR	V	Maximum, Harmonic U L3-L1	[34]
3068	FLOAT	RD/WR	V	Maximum, Harmonic U L3-L1	[35]
3070	FLOAT	RD/WR	V	Maximum, Harmonic U L3-L1	[36]
3072	FLOAT	RD/WR	V	Maximum, Harmonic U L3-L1	[37]
3074	FLOAT	RD/WR	V	Maximum, Harmonic U L3-L1	[38]
3076	FLOAT	RD/WR	V	Maximum, Harmonic U L3-L1	[39]
3118	FLOAT	RD/WR	A	Maximum, Harmonic I L1	[0]
3120	FLOAT	RD/WR	A	Maximum, Harmonic I L1	[1]
3122	FLOAT	RD/WR	A	Maximum, Harmonic I L1	[2]
3124	FLOAT	RD/WR	A	Maximum, Harmonic I L1	[3]
3126	FLOAT	RD/WR	A	Maximum, Harmonic I L1	[4]
3128	FLOAT	RD/WR	A	Maximum, Harmonic I L1	[5]
3130	FLOAT	RD/WR	A	Maximum, Harmonic I L1	[6]
3132	FLOAT	RD/WR	A	Maximum, Harmonic I L1	[7]
3134	FLOAT	RD/WR	A	Maximum, Harmonic I L1	[8]
3136	FLOAT	RD/WR	A	Maximum, Harmonic I L1	[9]
3138	FLOAT	RD/WR	A	Maximum, Harmonic I L1	[10]
3140	FLOAT	RD/WR	A	Maximum, Harmonic I L1	[11]
3142	FLOAT	RD/WR	A	Maximum, Harmonic I L1	[12]
3144	FLOAT	RD/WR	A	Maximum, Harmonic I L1	[13]
3146	FLOAT	RD/WR	A	Maximum, Harmonic I L1	[14]
3148	FLOAT	RD/WR	A	Maximum, Harmonic I L1	[15]
3150	FLOAT	RD/WR	A	Maximum, Harmonic I L1	[16]
3152	FLOAT	RD/WR	A	Maximum, Harmonic I L1	[17]
3154	FLOAT	RD/WR	A	Maximum, Harmonic I L1	[18]
3156	FLOAT	RD/WR	A	Maximum, Harmonic I L1	[19]
3158	FLOAT	RD/WR	A	Maximum, Harmonic I L1	[20]
3160	FLOAT	RD/WR	A	Maximum, Harmonic I L1	[21]
3162	FLOAT	RD/WR	A	Maximum, Harmonic I L1	[22]
3164	FLOAT	RD/WR	A	Maximum, Harmonic I L1	[23]

Address	Format	RD/WR	Unit	Note	Index
3166	FLOAT	RD/WR	A	Maximum, Harmonic I L1	[24]
3168	FLOAT	RD/WR	A	Maximum, Harmonic I L1	[25]
3170	FLOAT	RD/WR	A	Maximum, Harmonic I L1	[26]
3172	FLOAT	RD/WR	A	Maximum, Harmonic I L1	[27]
3174	FLOAT	RD/WR	A	Maximum, Harmonic I L1	[28]
3176	FLOAT	RD/WR	A	Maximum, Harmonic I L1	[29]
3178	FLOAT	RD/WR	A	Maximum, Harmonic I L1	[30]
3180	FLOAT	RD/WR	A	Maximum, Harmonic I L1	[31]
3182	FLOAT	RD/WR	A	Maximum, Harmonic I L1	[32]
3184	FLOAT	RD/WR	A	Maximum, Harmonic I L1	[33]
3186	FLOAT	RD/WR	A	Maximum, Harmonic I L1	[34]
3188	FLOAT	RD/WR	A	Maximum, Harmonic I L1	[35]
3190	FLOAT	RD/WR	A	Maximum, Harmonic I L1	[36]
3192	FLOAT	RD/WR	A	Maximum, Harmonic I L1	[37]
3194	FLOAT	RD/WR	A	Maximum, Harmonic I L1	[38]
3196	FLOAT	RD/WR	A	Maximum, Harmonic I L1	[39]
3198	FLOAT	RD/WR	A	Maximum, Harmonic I L2	[0]
3200	FLOAT	RD/WR	A	Maximum, Harmonic I L2	[1]
3202	FLOAT	RD/WR	A	Maximum, Harmonic I L2	[2]
3204	FLOAT	RD/WR	A	Maximum, Harmonic I L2	[3]
3206	FLOAT	RD/WR	A	Maximum, Harmonic I L2	[4]
3208	FLOAT	RD/WR	A	Maximum, Harmonic I L2	[5]
3210	FLOAT	RD/WR	A	Maximum, Harmonic I L2	[6]
3212	FLOAT	RD/WR	A	Maximum, Harmonic I L2	[7]
3214	FLOAT	RD/WR	A	Maximum, Harmonic I L2	[8]
3216	FLOAT	RD/WR	A	Maximum, Harmonic I L2	[9]
3218	FLOAT	RD/WR	A	Maximum, Harmonic I L2	[10]
3220	FLOAT	RD/WR	A	Maximum, Harmonic I L2	[11]
3222	FLOAT	RD/WR	A	Maximum, Harmonic I L2	[12]
3224	FLOAT	RD/WR	A	Maximum, Harmonic I L2	[13]
3226	FLOAT	RD/WR	A	Maximum, Harmonic I L2	[14]
3228	FLOAT	RD/WR	A	Maximum, Harmonic I L2	[15]
3230	FLOAT	RD/WR	A	Maximum, Harmonic I L2	[16]
3232	FLOAT	RD/WR	A	Maximum, Harmonic I L2	[17]
3234	FLOAT	RD/WR	A	Maximum, Harmonic I L2	[18]
3236	FLOAT	RD/WR	A	Maximum, Harmonic I L2	[19]
3238	FLOAT	RD/WR	A	Maximum, Harmonic I L2	[20]
3240	FLOAT	RD/WR	A	Maximum, Harmonic I L2	[21]
3242	FLOAT	RD/WR	A	Maximum, Harmonic I L2	[22]
3244	FLOAT	RD/WR	A	Maximum, Harmonic I L2	[23]
3246	FLOAT	RD/WR	A	Maximum, Harmonic I L2	[24]
3248	FLOAT	RD/WR	A	Maximum, Harmonic I L2	[25]
3250	FLOAT	RD/WR	A	Maximum, Harmonic I L2	[26]
3252	FLOAT	RD/WR	A	Maximum, Harmonic I L2	[27]
3254	FLOAT	RD/WR	A	Maximum, Harmonic I L2	[28]
3256	FLOAT	RD/WR	A	Maximum, Harmonic I L2	[29]
3258	FLOAT	RD/WR	A	Maximum, Harmonic I L2	[30]
3260	FLOAT	RD/WR	A	Maximum, Harmonic I L2	[31]
3262	FLOAT	RD/WR	A	Maximum, Harmonic I L2	[32]
3264	FLOAT	RD/WR	A	Maximum, Harmonic I L2	[33]
3266	FLOAT	RD/WR	A	Maximum, Harmonic I L2	[34]
3268	FLOAT	RD/WR	A	Maximum, Harmonic I L2	[35]
3270	FLOAT	RD/WR	A	Maximum, Harmonic I L2	[36]
3272	FLOAT	RD/WR	A	Maximum, Harmonic I L2	[37]
3274	FLOAT	RD/WR	A	Maximum, Harmonic I L2	[38]
3276	FLOAT	RD/WR	A	Maximum, Harmonic I L2	[39]
3278	FLOAT	RD/WR	A	Maximum, Harmonic I L3	[0]
3280	FLOAT	RD/WR	A	Maximum, Harmonic I L3	[1]
3282	FLOAT	RD/WR	A	Maximum, Harmonic I L3	[2]
3284	FLOAT	RD/WR	A	Maximum, Harmonic I L3	[3]
3286	FLOAT	RD/WR	A	Maximum, Harmonic I L3	[4]
3288	FLOAT	RD/WR	A	Maximum, Harmonic I L3	[5]
3290	FLOAT	RD/WR	A	Maximum, Harmonic I L3	[6]
3292	FLOAT	RD/WR	A	Maximum, Harmonic I L3	[7]
3294	FLOAT	RD/WR	A	Maximum, Harmonic I L3	[8]
3296	FLOAT	RD/WR	A	Maximum, Harmonic I L3	[9]

Address	Format	RD/WR	Unit	Note	Index
3298	FLOAT	RD/WR	A	Maximum, Harmonic I L3	[10]
3300	FLOAT	RD/WR	A	Maximum, Harmonic I L3	[11]
3302	FLOAT	RD/WR	A	Maximum, Harmonic I L3	[12]
3304	FLOAT	RD/WR	A	Maximum, Harmonic I L3	[13]
3306	FLOAT	RD/WR	A	Maximum, Harmonic I L3	[14]
3308	FLOAT	RD/WR	A	Maximum, Harmonic I L3	[15]
3310	FLOAT	RD/WR	A	Maximum, Harmonic I L3	[16]
3312	FLOAT	RD/WR	A	Maximum, Harmonic I L3	[17]
3314	FLOAT	RD/WR	A	Maximum, Harmonic I L3	[18]
3316	FLOAT	RD/WR	A	Maximum, Harmonic I L3	[19]
3318	FLOAT	RD/WR	A	Maximum, Harmonic I L3	[20]
3320	FLOAT	RD/WR	A	Maximum, Harmonic I L3	[21]
3322	FLOAT	RD/WR	A	Maximum, Harmonic I L3	[22]
3324	FLOAT	RD/WR	A	Maximum, Harmonic I L3	[23]
3326	FLOAT	RD/WR	A	Maximum, Harmonic I L3	[24]
3328	FLOAT	RD/WR	A	Maximum, Harmonic I L3	[25]
3330	FLOAT	RD/WR	A	Maximum, Harmonic I L3	[26]
3332	FLOAT	RD/WR	A	Maximum, Harmonic I L3	[27]
3334	FLOAT	RD/WR	A	Maximum, Harmonic I L3	[28]
3336	FLOAT	RD/WR	A	Maximum, Harmonic I L3	[29]
3338	FLOAT	RD/WR	A	Maximum, Harmonic I L3	[30]
3340	FLOAT	RD/WR	A	Maximum, Harmonic I L3	[31]
3342	FLOAT	RD/WR	A	Maximum, Harmonic I L3	[32]
3344	FLOAT	RD/WR	A	Maximum, Harmonic I L3	[33]
3346	FLOAT	RD/WR	A	Maximum, Harmonic I L3	[34]
3348	FLOAT	RD/WR	A	Maximum, Harmonic I L3	[35]
3350	FLOAT	RD/WR	A	Maximum, Harmonic I L3	[36]
3352	FLOAT	RD/WR	A	Maximum, Harmonic I L3	[37]
3354	FLOAT	RD/WR	A	Maximum, Harmonic I L3	[38]
3356	FLOAT	RD/WR	A	Maximum, Harmonic I L3	[39]

Maximum values, type short, fourier analysis

The measured values in short format do not contain current and voltage transformer ratios.

Address	Format	RD/WR	Unit	Note	Index	Resolution
4395	SHORT	RD/WR	V	Maximum, Harmonic U L1	[0]	0,1
4396	SHORT	RD/WR	V	Maximum, Harmonic U L1	[1]	0,1
4397	SHORT	RD/WR	V	Maximum, Harmonic U L1	[2]	0,1
4398	SHORT	RD/WR	V	Maximum, Harmonic U L1	[3]	0,1
4399	SHORT	RD/WR	V	Maximum, Harmonic U L1	[4]	0,1
4400	SHORT	RD/WR	V	Maximum, Harmonic U L1	[5]	0,1
4401	SHORT	RD/WR	V	Maximum, Harmonic U L1	[6]	0,1
4402	SHORT	RD/WR	V	Maximum, Harmonic U L1	[7]	0,1
4403	SHORT	RD/WR	V	Maximum, Harmonic U L1	[8]	0,1
4404	SHORT	RD/WR	V	Maximum, Harmonic U L1	[9]	0,1
4405	SHORT	RD/WR	V	Maximum, Harmonic U L1	[10]	0,1
4406	SHORT	RD/WR	V	Maximum, Harmonic U L1	[11]	0,1
4407	SHORT	RD/WR	V	Maximum, Harmonic U L1	[12]	0,1
4408	SHORT	RD/WR	V	Maximum, Harmonic U L1	[13]	0,1
4409	SHORT	RD/WR	V	Maximum, Harmonic U L1	[14]	0,1
4410	SHORT	RD/WR	V	Maximum, Harmonic U L1	[15]	0,1
4411	SHORT	RD/WR	V	Maximum, Harmonic U L1	[16]	0,1
4412	SHORT	RD/WR	V	Maximum, Harmonic U L1	[17]	0,1
4413	SHORT	RD/WR	V	Maximum, Harmonic U L1	[18]	0,1
4414	SHORT	RD/WR	V	Maximum, Harmonic U L1	[19]	0,1
4415	SHORT	RD/WR	V	Maximum, Harmonic U L1	[20]	0,1
4416	SHORT	RD/WR	V	Maximum, Harmonic U L1	[21]	0,1
4417	SHORT	RD/WR	V	Maximum, Harmonic U L1	[22]	0,1
4418	SHORT	RD/WR	V	Maximum, Harmonic U L1	[23]	0,1
4419	SHORT	RD/WR	V	Maximum, Harmonic U L1	[24]	0,1
4420	SHORT	RD/WR	V	Maximum, Harmonic U L1	[25]	0,1
4421	SHORT	RD/WR	V	Maximum, Harmonic U L1	[26]	0,1
4422	SHORT	RD/WR	V	Maximum, Harmonic U L1	[27]	0,1
4423	SHORT	RD/WR	V	Maximum, Harmonic U L1	[28]	0,1
4424	SHORT	RD/WR	V	Maximum, Harmonic U L1	[29]	0,1
4425	SHORT	RD/WR	V	Maximum, Harmonic U L1	[30]	0,1
4426	SHORT	RD/WR	V	Maximum, Harmonic U L1	[31]	0,1
4427	SHORT	RD/WR	V	Maximum, Harmonic U L1	[32]	0,1
4428	SHORT	RD/WR	V	Maximum, Harmonic U L1	[33]	0,1
4429	SHORT	RD/WR	V	Maximum, Harmonic U L1	[34]	0,1
4430	SHORT	RD/WR	V	Maximum, Harmonic U L1	[35]	0,1
4431	SHORT	RD/WR	V	Maximum, Harmonic U L1	[36]	0,1
4432	SHORT	RD/WR	V	Maximum, Harmonic U L1	[37]	0,1
4433	SHORT	RD/WR	V	Maximum, Harmonic U L1	[38]	0,1
4434	SHORT	RD/WR	V	Maximum, Harmonic U L1	[39]	0,1
4435	SHORT	RD/WR	V	Maximum, Harmonic U L2	[0]	0,1
4436	SHORT	RD/WR	V	Maximum, Harmonic U L2	[1]	0,1
4437	SHORT	RD/WR	V	Maximum, Harmonic U L2	[2]	0,1
4438	SHORT	RD/WR	V	Maximum, Harmonic U L2	[3]	0,1
4439	SHORT	RD/WR	V	Maximum, Harmonic U L2	[4]	0,1
4440	SHORT	RD/WR	V	Maximum, Harmonic U L2	[5]	0,1
4441	SHORT	RD/WR	V	Maximum, Harmonic U L2	[6]	0,1
4442	SHORT	RD/WR	V	Maximum, Harmonic U L2	[7]	0,1
4443	SHORT	RD/WR	V	Maximum, Harmonic U L2	[8]	0,1
4444	SHORT	RD/WR	V	Maximum, Harmonic U L2	[9]	0,1
4445	SHORT	RD/WR	V	Maximum, Harmonic U L2	[10]	0,1
4446	SHORT	RD/WR	V	Maximum, Harmonic U L2	[11]	0,1
4447	SHORT	RD/WR	V	Maximum, Harmonic U L2	[12]	0,1
4448	SHORT	RD/WR	V	Maximum, Harmonic U L2	[13]	0,1
4449	SHORT	RD/WR	V	Maximum, Harmonic U L2	[14]	0,1
4450	SHORT	RD/WR	V	Maximum, Harmonic U L2	[15]	0,1
4451	SHORT	RD/WR	V	Maximum, Harmonic U L2	[16]	0,1
4452	SHORT	RD/WR	V	Maximum, Harmonic U L2	[17]	0,1
4453	SHORT	RD/WR	V	Maximum, Harmonic U L2	[18]	0,1
4454	SHORT	RD/WR	V	Maximum, Harmonic U L2	[19]	0,1
4455	SHORT	RD/WR	V	Maximum, Harmonic U L2	[20]	0,1
4456	SHORT	RD/WR	V	Maximum, Harmonic U L2	[21]	0,1
4457	SHORT	RD/WR	V	Maximum, Harmonic U L2	[22]	0,1
4458	SHORT	RD/WR	V	Maximum, Harmonic U L2	[23]	0,1
4459	SHORT	RD/WR	V	Maximum, Harmonic U L2	[24]	0,1
4460	SHORT	RD/WR	V	Maximum, Harmonic U L2	[25]	0,1

Address	Format	RD/WR	Unit	Note	Index	Resolution
4461	SHORT	RD/WR	V	Maximum, Harmonic U L2	[26]	0,1
4462	SHORT	RD/WR	V	Maximum, Harmonic U L2	[27]	0,1
4463	SHORT	RD/WR	V	Maximum, Harmonic U L2	[28]	0,1
4464	SHORT	RD/WR	V	Maximum, Harmonic U L2	[29]	0,1
4465	SHORT	RD/WR	V	Maximum, Harmonic U L2	[30]	0,1
4466	SHORT	RD/WR	V	Maximum, Harmonic U L2	[31]	0,1
4467	SHORT	RD/WR	V	Maximum, Harmonic U L2	[32]	0,1
4468	SHORT	RD/WR	V	Maximum, Harmonic U L2	[33]	0,1
4469	SHORT	RD/WR	V	Maximum, Harmonic U L2	[34]	0,1
4470	SHORT	RD/WR	V	Maximum, Harmonic U L2	[35]	0,1
4471	SHORT	RD/WR	V	Maximum, Harmonic U L2	[36]	0,1
4472	SHORT	RD/WR	V	Maximum, Harmonic U L2	[37]	0,1
4473	SHORT	RD/WR	V	Maximum, Harmonic U L2	[38]	0,1
4474	SHORT	RD/WR	V	Maximum, Harmonic U L2	[39]	0,1
4475	SHORT	RD/WR	V	Maximum, Harmonic U L3	[0]	0,1
4476	SHORT	RD/WR	V	Maximum, Harmonic U L3	[1]	0,1
4477	SHORT	RD/WR	V	Maximum, Harmonic U L3	[2]	0,1
4478	SHORT	RD/WR	V	Maximum, Harmonic U L3	[3]	0,1
4479	SHORT	RD/WR	V	Maximum, Harmonic U L3	[4]	0,1
4480	SHORT	RD/WR	V	Maximum, Harmonic U L3	[5]	0,1
4481	SHORT	RD/WR	V	Maximum, Harmonic U L3	[6]	0,1
4482	SHORT	RD/WR	V	Maximum, Harmonic U L3	[7]	0,1
4483	SHORT	RD/WR	V	Maximum, Harmonic U L3	[8]	0,1
4484	SHORT	RD/WR	V	Maximum, Harmonic U L3	[9]	0,1
4485	SHORT	RD/WR	V	Maximum, Harmonic U L3	[10]	0,1
4486	SHORT	RD/WR	V	Maximum, Harmonic U L3	[11]	0,1
4487	SHORT	RD/WR	V	Maximum, Harmonic U L3	[12]	0,1
4488	SHORT	RD/WR	V	Maximum, Harmonic U L3	[13]	0,1
4489	SHORT	RD/WR	V	Maximum, Harmonic U L3	[14]	0,1
4490	SHORT	RD/WR	V	Maximum, Harmonic U L3	[15]	0,1
4491	SHORT	RD/WR	V	Maximum, Harmonic U L3	[16]	0,1
4492	SHORT	RD/WR	V	Maximum, Harmonic U L3	[17]	0,1
4493	SHORT	RD/WR	V	Maximum, Harmonic U L3	[18]	0,1
4494	SHORT	RD/WR	V	Maximum, Harmonic U L3	[19]	0,1
4495	SHORT	RD/WR	V	Maximum, Harmonic U L3	[20]	0,1
4496	SHORT	RD/WR	V	Maximum, Harmonic U L3	[21]	0,1
4497	SHORT	RD/WR	V	Maximum, Harmonic U L3	[22]	0,1
4498	SHORT	RD/WR	V	Maximum, Harmonic U L3	[23]	0,1
4499	SHORT	RD/WR	V	Maximum, Harmonic U L3	[24]	0,1
4500	SHORT	RD/WR	V	Maximum, Harmonic U L3	[25]	0,1
4501	SHORT	RD/WR	V	Maximum, Harmonic U L3	[26]	0,1
4502	SHORT	RD/WR	V	Maximum, Harmonic U L3	[27]	0,1
4503	SHORT	RD/WR	V	Maximum, Harmonic U L3	[28]	0,1
4504	SHORT	RD/WR	V	Maximum, Harmonic U L3	[29]	0,1
4505	SHORT	RD/WR	V	Maximum, Harmonic U L3	[30]	0,1
4506	SHORT	RD/WR	V	Maximum, Harmonic U L3	[31]	0,1
4507	SHORT	RD/WR	V	Maximum, Harmonic U L3	[32]	0,1
4508	SHORT	RD/WR	V	Maximum, Harmonic U L3	[33]	0,1
4509	SHORT	RD/WR	V	Maximum, Harmonic U L3	[34]	0,1
4510	SHORT	RD/WR	V	Maximum, Harmonic U L3	[35]	0,1
4511	SHORT	RD/WR	V	Maximum, Harmonic U L3	[36]	0,1
4512	SHORT	RD/WR	V	Maximum, Harmonic U L3	[37]	0,1
4513	SHORT	RD/WR	V	Maximum, Harmonic U L3	[38]	0,1
4514	SHORT	RD/WR	V	Maximum, Harmonic U L3	[39]	0,1
4515	SHORT	RD/WR	V	Maximum, Harmonic U L1-L2	[0]	0,1
4516	SHORT	RD/WR	V	Maximum, Harmonic U L1-L2	[1]	0,1
4517	SHORT	RD/WR	V	Maximum, Harmonic U L1-L2	[2]	0,1
4518	SHORT	RD/WR	V	Maximum, Harmonic U L1-L2	[3]	0,1
4519	SHORT	RD/WR	V	Maximum, Harmonic U L1-L2	[4]	0,1
4520	SHORT	RD/WR	V	Maximum, Harmonic U L1-L2	[5]	0,1
4521	SHORT	RD/WR	V	Maximum, Harmonic U L1-L2	[6]	0,1
4522	SHORT	RD/WR	V	Maximum, Harmonic U L1-L2	[7]	0,1
4523	SHORT	RD/WR	V	Maximum, Harmonic U L1-L2	[8]	0,1
4524	SHORT	RD/WR	V	Maximum, Harmonic U L1-L2	[9]	0,1
4525	SHORT	RD/WR	V	Maximum, Harmonic U L1-L2	[10]	0,1
4526	SHORT	RD/WR	V	Maximum, Harmonic U L1-L2	[11]	0,1

Address	Format	RD/WR	Unit	Note	Index	Resolution
4527	SHORT	RD/WR	V	Maximum, Harmonic U L1-L2	[12]	0,1
4528	SHORT	RD/WR	V	Maximum, Harmonic U L1-L2	[13]	0,1
4529	SHORT	RD/WR	V	Maximum, Harmonic U L1-L2	[14]	0,1
4530	SHORT	RD/WR	V	Maximum, Harmonic U L1-L2	[15]	0,1
4531	SHORT	RD/WR	V	Maximum, Harmonic U L1-L2	[16]	0,1
4532	SHORT	RD/WR	V	Maximum, Harmonic U L1-L2	[17]	0,1
4533	SHORT	RD/WR	V	Maximum, Harmonic U L1-L2	[18]	0,1
4534	SHORT	RD/WR	V	Maximum, Harmonic U L1-L2	[19]	0,1
4535	SHORT	RD/WR	V	Maximum, Harmonic U L1-L2	[20]	0,1
4536	SHORT	RD/WR	V	Maximum, Harmonic U L1-L2	[21]	0,1
4537	SHORT	RD/WR	V	Maximum, Harmonic U L1-L2	[22]	0,1
4538	SHORT	RD/WR	V	Maximum, Harmonic U L1-L2	[23]	0,1
4539	SHORT	RD/WR	V	Maximum, Harmonic U L1-L2	[24]	0,1
4540	SHORT	RD/WR	V	Maximum, Harmonic U L1-L2	[25]	0,1
4541	SHORT	RD/WR	V	Maximum, Harmonic U L1-L2	[26]	0,1
4542	SHORT	RD/WR	V	Maximum, Harmonic U L1-L2	[27]	0,1
4543	SHORT	RD/WR	V	Maximum, Harmonic U L1-L2	[28]	0,1
4544	SHORT	RD/WR	V	Maximum, Harmonic U L1-L2	[29]	0,1
4545	SHORT	RD/WR	V	Maximum, Harmonic U L1-L2	[30]	0,1
4546	SHORT	RD/WR	V	Maximum, Harmonic U L1-L2	[31]	0,1
4547	SHORT	RD/WR	V	Maximum, Harmonic U L1-L2	[32]	0,1
4548	SHORT	RD/WR	V	Maximum, Harmonic U L1-L2	[33]	0,1
4549	SHORT	RD/WR	V	Maximum, Harmonic U L1-L2	[34]	0,1
4550	SHORT	RD/WR	V	Maximum, Harmonic U L1-L2	[35]	0,1
4551	SHORT	RD/WR	V	Maximum, Harmonic U L1-L2	[36]	0,1
4552	SHORT	RD/WR	V	Maximum, Harmonic U L1-L2	[37]	0,1
4553	SHORT	RD/WR	V	Maximum, Harmonic U L1-L2	[38]	0,1
4554	SHORT	RD/WR	V	Maximum, Harmonic U L1-L2	[39]	0,1
4555	SHORT	RD/WR	V	Maximum, Harmonic U L2-L3	[0]	0,1
4556	SHORT	RD/WR	V	Maximum, Harmonic U L2-L3	[1]	0,1
4557	SHORT	RD/WR	V	Maximum, Harmonic U L2-L3	[2]	0,1
4558	SHORT	RD/WR	V	Maximum, Harmonic U L2-L3	[3]	0,1
4559	SHORT	RD/WR	V	Maximum, Harmonic U L2-L3	[4]	0,1
4560	SHORT	RD/WR	V	Maximum, Harmonic U L2-L3	[5]	0,1
4561	SHORT	RD/WR	V	Maximum, Harmonic U L2-L3	[6]	0,1
4562	SHORT	RD/WR	V	Maximum, Harmonic U L2-L3	[7]	0,1
4563	SHORT	RD/WR	V	Maximum, Harmonic U L2-L3	[8]	0,1
4564	SHORT	RD/WR	V	Maximum, Harmonic U L2-L3	[9]	0,1
4565	SHORT	RD/WR	V	Maximum, Harmonic U L2-L3	[10]	0,1
4566	SHORT	RD/WR	V	Maximum, Harmonic U L2-L3	[11]	0,1
4567	SHORT	RD/WR	V	Maximum, Harmonic U L2-L3	[12]	0,1
4568	SHORT	RD/WR	V	Maximum, Harmonic U L2-L3	[13]	0,1
4569	SHORT	RD/WR	V	Maximum, Harmonic U L2-L3	[14]	0,1
4570	SHORT	RD/WR	V	Maximum, Harmonic U L2-L3	[15]	0,1
4571	SHORT	RD/WR	V	Maximum, Harmonic U L2-L3	[16]	0,1
4572	SHORT	RD/WR	V	Maximum, Harmonic U L2-L3	[17]	0,1
4573	SHORT	RD/WR	V	Maximum, Harmonic U L2-L3	[18]	0,1
4574	SHORT	RD/WR	V	Maximum, Harmonic U L2-L3	[19]	0,1
4575	SHORT	RD/WR	V	Maximum, Harmonic U L2-L3	[20]	0,1
4576	SHORT	RD/WR	V	Maximum, Harmonic U L2-L3	[21]	0,1
4577	SHORT	RD/WR	V	Maximum, Harmonic U L2-L3	[22]	0,1
4578	SHORT	RD/WR	V	Maximum, Harmonic U L2-L3	[23]	0,1
4579	SHORT	RD/WR	V	Maximum, Harmonic U L2-L3	[24]	0,1
4580	SHORT	RD/WR	V	Maximum, Harmonic U L2-L3	[25]	0,1
4581	SHORT	RD/WR	V	Maximum, Harmonic U L2-L3	[26]	0,1
4582	SHORT	RD/WR	V	Maximum, Harmonic U L2-L3	[27]	0,1
4583	SHORT	RD/WR	V	Maximum, Harmonic U L2-L3	[28]	0,1
4584	SHORT	RD/WR	V	Maximum, Harmonic U L2-L3	[29]	0,1
4585	SHORT	RD/WR	V	Maximum, Harmonic U L2-L3	[30]	0,1
4586	SHORT	RD/WR	V	Maximum, Harmonic U L2-L3	[31]	0,1
4587	SHORT	RD/WR	V	Maximum, Harmonic U L2-L3	[32]	0,1
4588	SHORT	RD/WR	V	Maximum, Harmonic U L2-L3	[33]	0,1
4589	SHORT	RD/WR	V	Maximum, Harmonic U L2-L3	[34]	0,1
4590	SHORT	RD/WR	V	Maximum, Harmonic U L2-L3	[35]	0,1
4591	SHORT	RD/WR	V	Maximum, Harmonic U L2-L3	[36]	0,1
4592	SHORT	RD/WR	V	Maximum, Harmonic U L2-L3	[37]	0,1

Address	Format	RD/WR	Unit	Note	Index	Resolution
4593	SHORT	RD/WR	V	Maximum, Harmonic U L2-L3	[38]	0,1
4594	SHORT	RD/WR	V	Maximum, Harmonic U L2-L3	[39]	0,1
4595	SHORT	RD/WR	V	Maximum, Harmonic U L1-L3	[0]	0,1
4596	SHORT	RD/WR	V	Maximum, Harmonic U L1-L3	[1]	0,1
4597	SHORT	RD/WR	V	Maximum, Harmonic U L1-L3	[2]	0,1
4598	SHORT	RD/WR	V	Maximum, Harmonic U L1-L3	[3]	0,1
4599	SHORT	RD/WR	V	Maximum, Harmonic U L1-L3	[4]	0,1
4600	SHORT	RD/WR	V	Maximum, Harmonic U L1-L3	[5]	0,1
4601	SHORT	RD/WR	V	Maximum, Harmonic U L1-L3	[6]	0,1
4602	SHORT	RD/WR	V	Maximum, Harmonic U L1-L3	[7]	0,1
4603	SHORT	RD/WR	V	Maximum, Harmonic U L1-L3	[8]	0,1
4604	SHORT	RD/WR	V	Maximum, Harmonic U L1-L3	[9]	0,1
4605	SHORT	RD/WR	V	Maximum, Harmonic U L1-L3	[10]	0,1
4606	SHORT	RD/WR	V	Maximum, Harmonic U L1-L3	[11]	0,1
4607	SHORT	RD/WR	V	Maximum, Harmonic U L1-L3	[12]	0,1
4608	SHORT	RD/WR	V	Maximum, Harmonic U L1-L3	[13]	0,1
4609	SHORT	RD/WR	V	Maximum, Harmonic U L1-L3	[14]	0,1
4610	SHORT	RD/WR	V	Maximum, Harmonic U L1-L3	[15]	0,1
4611	SHORT	RD/WR	V	Maximum, Harmonic U L1-L3	[16]	0,1
4612	SHORT	RD/WR	V	Maximum, Harmonic U L1-L3	[17]	0,1
4613	SHORT	RD/WR	V	Maximum, Harmonic U L1-L3	[18]	0,1
4614	SHORT	RD/WR	V	Maximum, Harmonic U L1-L3	[19]	0,1
4615	SHORT	RD/WR	V	Maximum, Harmonic U L1-L3	[20]	0,1
4616	SHORT	RD/WR	V	Maximum, Harmonic U L1-L3	[21]	0,1
4617	SHORT	RD/WR	V	Maximum, Harmonic U L1-L3	[22]	0,1
4618	SHORT	RD/WR	V	Maximum, Harmonic U L1-L3	[23]	0,1
4619	SHORT	RD/WR	V	Maximum, Harmonic U L1-L3	[24]	0,1
4620	SHORT	RD/WR	V	Maximum, Harmonic U L1-L3	[25]	0,1
4621	SHORT	RD/WR	V	Maximum, Harmonic U L1-L3	[26]	0,1
4622	SHORT	RD/WR	V	Maximum, Harmonic U L1-L3	[27]	0,1
4623	SHORT	RD/WR	V	Maximum, Harmonic U L1-L3	[28]	0,1
4624	SHORT	RD/WR	V	Maximum, Harmonic U L1-L3	[29]	0,1
4625	SHORT	RD/WR	V	Maximum, Harmonic U L1-L3	[30]	0,1
4626	SHORT	RD/WR	V	Maximum, Harmonic U L1-L3	[31]	0,1
4627	SHORT	RD/WR	V	Maximum, Harmonic U L1-L3	[32]	0,1
4628	SHORT	RD/WR	V	Maximum, Harmonic U L1-L3	[33]	0,1
4629	SHORT	RD/WR	V	Maximum, Harmonic U L1-L3	[34]	0,1
4630	SHORT	RD/WR	V	Maximum, Harmonic U L1-L3	[35]	0,1
4631	SHORT	RD/WR	V	Maximum, Harmonic U L1-L3	[36]	0,1
4632	SHORT	RD/WR	V	Maximum, Harmonic U L1-L3	[37]	0,1
4633	SHORT	RD/WR	V	Maximum, Harmonic U L1-L3	[38]	0,1
4634	SHORT	RD/WR	V	Maximum, Harmonic U L1-L3	[39]	0,1
4655	SHORT	RD/WR	mA	Maximum, Harmonic I L1	[0]	1
4656	SHORT	RD/WR	mA	Maximum, Harmonic I L1	[1]	1
4657	SHORT	RD/WR	mA	Maximum, Harmonic I L1	[2]	1
4658	SHORT	RD/WR	mA	Maximum, Harmonic I L1	[3]	1
4659	SHORT	RD/WR	mA	Maximum, Harmonic I L1	[4]	1
4660	SHORT	RD/WR	mA	Maximum, Harmonic I L1	[5]	1
4661	SHORT	RD/WR	mA	Maximum, Harmonic I L1	[6]	1
4662	SHORT	RD/WR	mA	Maximum, Harmonic I L1	[7]	1
4663	SHORT	RD/WR	mA	Maximum, Harmonic I L1	[8]	1
4664	SHORT	RD/WR	mA	Maximum, Harmonic I L1	[9]	1
4665	SHORT	RD/WR	mA	Maximum, Harmonic I L1	[10]	1
4666	SHORT	RD/WR	mA	Maximum, Harmonic I L1	[11]	1
4667	SHORT	RD/WR	mA	Maximum, Harmonic I L1	[12]	1
4668	SHORT	RD/WR	mA	Maximum, Harmonic I L1	[13]	1
4669	SHORT	RD/WR	mA	Maximum, Harmonic I L1	[14]	1
4670	SHORT	RD/WR	mA	Maximum, Harmonic I L1	[15]	1
4671	SHORT	RD/WR	mA	Maximum, Harmonic I L1	[16]	1
4672	SHORT	RD/WR	mA	Maximum, Harmonic I L1	[17]	1
4673	SHORT	RD/WR	mA	Maximum, Harmonic I L1	[18]	1
4674	SHORT	RD/WR	mA	Maximum, Harmonic I L1	[19]	1
4675	SHORT	RD/WR	mA	Maximum, Harmonic I L1	[20]	1
4676	SHORT	RD/WR	mA	Maximum, Harmonic I L1	[21]	1
4677	SHORT	RD/WR	mA	Maximum, Harmonic I L1	[22]	1
4678	SHORT	RD/WR	mA	Maximum, Harmonic I L1	[23]	1

Address	Format	RD/WR	Unit	Note	Index	Resolution
4679	SHORT	RD/WR	mA	Maximum, Harmonic I L1	[24]	1
4680	SHORT	RD/WR	mA	Maximum, Harmonic I L1	[25]	1
4681	SHORT	RD/WR	mA	Maximum, Harmonic I L1	[26]	1
4682	SHORT	RD/WR	mA	Maximum, Harmonic I L1	[27]	1
4683	SHORT	RD/WR	mA	Maximum, Harmonic I L1	[28]	1
4684	SHORT	RD/WR	mA	Maximum, Harmonic I L1	[29]	1
4685	SHORT	RD/WR	mA	Maximum, Harmonic I L1	[30]	1
4686	SHORT	RD/WR	mA	Maximum, Harmonic I L1	[31]	1
4687	SHORT	RD/WR	mA	Maximum, Harmonic I L1	[32]	1
4688	SHORT	RD/WR	mA	Maximum, Harmonic I L1	[33]	1
4689	SHORT	RD/WR	mA	Maximum, Harmonic I L1	[34]	1
4690	SHORT	RD/WR	mA	Maximum, Harmonic I L1	[35]	1
4691	SHORT	RD/WR	mA	Maximum, Harmonic I L1	[36]	1
4692	SHORT	RD/WR	mA	Maximum, Harmonic I L1	[37]	1
4693	SHORT	RD/WR	mA	Maximum, Harmonic I L1	[38]	1
4694	SHORT	RD/WR	mA	Maximum, Harmonic I L1	[39]	1
4695	SHORT	RD/WR	mA	Maximum, Harmonic I L2	[0]	1
4696	SHORT	RD/WR	mA	Maximum, Harmonic I L2	[1]	1
4697	SHORT	RD/WR	mA	Maximum, Harmonic I L2	[2]	1
4698	SHORT	RD/WR	mA	Maximum, Harmonic I L2	[3]	1
4699	SHORT	RD/WR	mA	Maximum, Harmonic I L2	[4]	1
4700	SHORT	RD/WR	mA	Maximum, Harmonic I L2	[5]	1
4701	SHORT	RD/WR	mA	Maximum, Harmonic I L2	[6]	1
4702	SHORT	RD/WR	mA	Maximum, Harmonic I L2	[7]	1
4703	SHORT	RD/WR	mA	Maximum, Harmonic I L2	[8]	1
4704	SHORT	RD/WR	mA	Maximum, Harmonic I L2	[9]	1
4705	SHORT	RD/WR	mA	Maximum, Harmonic I L2	[10]	1
4706	SHORT	RD/WR	mA	Maximum, Harmonic I L2	[11]	1
4707	SHORT	RD/WR	mA	Maximum, Harmonic I L2	[12]	1
4708	SHORT	RD/WR	mA	Maximum, Harmonic I L2	[13]	1
4709	SHORT	RD/WR	mA	Maximum, Harmonic I L2	[14]	1
4710	SHORT	RD/WR	mA	Maximum, Harmonic I L2	[15]	1
4711	SHORT	RD/WR	mA	Maximum, Harmonic I L2	[16]	1
4712	SHORT	RD/WR	mA	Maximum, Harmonic I L2	[17]	1
4713	SHORT	RD/WR	mA	Maximum, Harmonic I L2	[18]	1
4714	SHORT	RD/WR	mA	Maximum, Harmonic I L2	[19]	1
4715	SHORT	RD/WR	mA	Maximum, Harmonic I L2	[20]	1
4716	SHORT	RD/WR	mA	Maximum, Harmonic I L2	[21]	1
4717	SHORT	RD/WR	mA	Maximum, Harmonic I L2	[22]	1
4718	SHORT	RD/WR	mA	Maximum, Harmonic I L2	[23]	1
4719	SHORT	RD/WR	mA	Maximum, Harmonic I L2	[24]	1
4720	SHORT	RD/WR	mA	Maximum, Harmonic I L2	[25]	1
4721	SHORT	RD/WR	mA	Maximum, Harmonic I L2	[26]	1
4722	SHORT	RD/WR	mA	Maximum, Harmonic I L2	[27]	1
4723	SHORT	RD/WR	mA	Maximum, Harmonic I L2	[28]	1
4724	SHORT	RD/WR	mA	Maximum, Harmonic I L2	[29]	1
4725	SHORT	RD/WR	mA	Maximum, Harmonic I L2	[30]	1
4726	SHORT	RD/WR	mA	Maximum, Harmonic I L2	[31]	1
4727	SHORT	RD/WR	mA	Maximum, Harmonic I L2	[32]	1
4728	SHORT	RD/WR	mA	Maximum, Harmonic I L2	[33]	1
4729	SHORT	RD/WR	mA	Maximum, Harmonic I L2	[34]	1
4730	SHORT	RD/WR	mA	Maximum, Harmonic I L2	[35]	1
4731	SHORT	RD/WR	mA	Maximum, Harmonic I L2	[36]	1
4732	SHORT	RD/WR	mA	Maximum, Harmonic I L2	[37]	1
4733	SHORT	RD/WR	mA	Maximum, Harmonic I L2	[38]	1
4734	SHORT	RD/WR	mA	Maximum, Harmonic I L2	[39]	1
4735	SHORT	RD/WR	mA	Maximum, Harmonic I L3	[0]	1
4736	SHORT	RD/WR	mA	Maximum, Harmonic I L3	[1]	1
4737	SHORT	RD/WR	mA	Maximum, Harmonic I L3	[2]	1
4738	SHORT	RD/WR	mA	Maximum, Harmonic I L3	[3]	1
4739	SHORT	RD/WR	mA	Maximum, Harmonic I L3	[4]	1
4740	SHORT	RD/WR	mA	Maximum, Harmonic I L3	[5]	1
4741	SHORT	RD/WR	mA	Maximum, Harmonic I L3	[6]	1
4742	SHORT	RD/WR	mA	Maximum, Harmonic I L3	[7]	1
4743	SHORT	RD/WR	mA	Maximum, Harmonic I L3	[8]	1
4744	SHORT	RD/WR	mA	Maximum, Harmonic I L3	[9]	1

Address	Format	RD/WR	Unit	Note	Index	Resolution
4745	SHORT	RD/WR	mA	Maximum, Harmonic I L3	[10]	1
4746	SHORT	RD/WR	mA	Maximum, Harmonic I L3	[11]	1
4747	SHORT	RD/WR	mA	Maximum, Harmonic I L3	[12]	1
4748	SHORT	RD/WR	mA	Maximum, Harmonic I L3	[13]	1
4749	SHORT	RD/WR	mA	Maximum, Harmonic I L3	[14]	1
4750	SHORT	RD/WR	mA	Maximum, Harmonic I L3	[15]	1
4751	SHORT	RD/WR	mA	Maximum, Harmonic I L3	[16]	1
4752	SHORT	RD/WR	mA	Maximum, Harmonic I L3	[17]	1
4753	SHORT	RD/WR	mA	Maximum, Harmonic I L3	[18]	1
4754	SHORT	RD/WR	mA	Maximum, Harmonic I L3	[19]	1
4755	SHORT	RD/WR	mA	Maximum, Harmonic I L3	[20]	1
4756	SHORT	RD/WR	mA	Maximum, Harmonic I L3	[21]	1
4757	SHORT	RD/WR	mA	Maximum, Harmonic I L3	[22]	1
4758	SHORT	RD/WR	mA	Maximum, Harmonic I L3	[23]	1
4759	SHORT	RD/WR	mA	Maximum, Harmonic I L3	[24]	1
4760	SHORT	RD/WR	mA	Maximum, Harmonic I L3	[25]	1
4761	SHORT	RD/WR	mA	Maximum, Harmonic I L3	[26]	1
4762	SHORT	RD/WR	mA	Maximum, Harmonic I L3	[27]	1
4763	SHORT	RD/WR	mA	Maximum, Harmonic I L3	[28]	1
4764	SHORT	RD/WR	mA	Maximum, Harmonic I L3	[29]	1
4765	SHORT	RD/WR	mA	Maximum, Harmonic I L3	[30]	1
4766	SHORT	RD/WR	mA	Maximum, Harmonic I L3	[31]	1
4767	SHORT	RD/WR	mA	Maximum, Harmonic I L3	[32]	1
4768	SHORT	RD/WR	mA	Maximum, Harmonic I L3	[33]	1
4769	SHORT	RD/WR	mA	Maximum, Harmonic I L3	[34]	1
4770	SHORT	RD/WR	mA	Maximum, Harmonic I L3	[35]	1
4771	SHORT	RD/WR	mA	Maximum, Harmonic I L3	[36]	1
4772	SHORT	RD/WR	mA	Maximum, Harmonic I L3	[37]	1
4773	SHORT	RD/WR	mA	Maximum, Harmonic I L3	[38]	1
4774	SHORT	RD/WR	mA	Maximum, Harmonic I L3	[39]	1

Extension UMG96 RM-PN

Additional parameters and address list for the extensions UMG96RM-PN

Parameter

Address	Format	RD/WR	Unit	Note	Adjustment Area	Default
520	SHORT	RD/WR		Modbus Timeout: Time (in ms) after a Modbus request over the module is discarded to the base	0-10000	200
521	SHORT	RD/WR		Changeover of the digital IOs of the module 0=output, 1=input	0, 1	0
524	SHORT	RD/WR		Inverting digital output 3	0, 1	0
525	SHORT	RD/WR		Inverting digital output 4	0, 1	0
526	SHORT	RD/WR		Inverting digital output 5	0, 1	0
527	SHORT	RD/WR		Digital out 1, source Profinet: Source for base outputs (selection by Addr. 200 = 5)	0, 1	0
528	SHORT	RD/WR		Digital out 2, source Profinet: Source for base outputs (selection by Addr. 202 = 5)	0, 1	0
530	FLOAT	RD/WR		I4, current transformer, primary	0-1000000	5
532	FLOAT	RD/WR		I4, current transformer, secondary	1.0-5.0	5
534	FLOAT	RD/WR		I5, current transformer, primary	0.0-1000000.0	1
536	FLOAT	RD/WR		I5, current transformer, secondary	1.0-5.0	1
538	FLOAT	RD/WR		I6, current transformer, primary	0.0-1000000.0	1
540	FLOAT	RD/WR		I6, current transformer, secondary	1.0-5.0	1
542	SHORT	RD/WR		Type I5: 0=residual current, 1=temperature	0, 1	0
543	SHORT	RD/WR		Type I6: 0=residual current, 1=temperature	0, 1	0
544	FLOAT	RD/WR		Temperature offset, Temp1	-1000.0 - 1000.0	0
546	FLOAT	RD/WR		Temperature offset, Temp2	-1000.0 - 1000.0	0
548	SHORT	RD/WR		Temperature sensor, Temp1 (0=PT100, 1=PT1000, 2=KTY83, 3=KTY84, 4=resistor in ohm)	0-4	0
549	SHORT	RD/WR		Temperature sensor, Temp2 (0=PT100, 1=PT1000, 2=KTY83, 3=KTY84, 4=resistor in ohm)	0-4	0
550	SHORT	RD/WR		Tariff configuration input 1; if Input 1 is set, configurable counters are set in tariff 1 *	0-127	0
551	SHORT	RD/WR		Tariff configuration input 2; if Input 2 is set, configurable counters are set in tariff 2 *	0-127	0
552	SHORT	RD/WR		Tariff configuration input 3; if Input 3 is set, configurable counters are set in tariff 3 *	0-127	0
553	SHORT	RD/WR		Enable transformer connection ckeck channel I5	0,1	0
554	SHORT	RD/WR		Enable transformer connection ckeck channel I6	0,1	0
20010	UINT			Device IP address	0, 0xFFFFFFFF	0xA0A0AC8 (10.10.10.200)
20012	UINT			Device netmask	0, 0xFFFFFFFF	0xFFFFFFFF0 (255.255.255.0)
20014	UINT			Device gateway IP address	0, 0xFFFFFFFF	0xA0A0A01 (10.10.10.1)

Address	Format	RD/WR	Unit	Note	Adjustment Area	Default
25436	STRING	RD/WR		Device name UMG96RM-PN-2500-xxxx		
26000	UINT	RD		Serial number **		
26002	UINT	RD		Item number **		
26004	SHORT	RD		Release Base **		
26005	SHORT	RD		Modbus Adresse **		
26006	UINT	RD		Modbus RTU Baudrate **		
26008	SHORT	RD		Hardware Index **		

* Activation of the tariff meter by bitwise coding

Bit 0 = active energy, Bit 1 = active energy consumed, Bit 2 = active energy delivered, Bit 3 = reactive energy

Bit 4 = reactive energy ind., Bit 5 = reactive energy cap., Bit 6 = apparent energy

** Copy of the address of the base device (REST interface), available only in applications.

Measured values

Address	Format	RD/WR	Unit	Note	Index	Resolution
20050	SHORT			Digital-Out 3	0,1	
20051	SHORT			Digital-Out 4	0,1	
20052	SHORT			Digital-Out 5	0,1	
10000	FLOAT		A	I4 current		1
10002	FLOAT		A	I5 current		1
10004	FLOAT		A	I6 current		1
10006	FLOAT		°C	Temperature input 1		
10008	FLOAT		°C	Temperature input 2		
10010	SHORT			Digital-In 1	0,1	
10011	SHORT			Digital-In 2	0,1	
10012	SHORT			Digital-In 3	0,1	
10013	SHORT			Digital In Binary	0-7	
10014	SHORT			Transformer I5 not connected 0 = converter realised 1 = no converter realised	0,1	
10015	SHORT			Transformer I6 not connected 0 = converter realised 1 = no converter realised	0,1	

Extension UMG96 RM-P / -CBM

Additional parameters and address list for the extensions UMG96RM-P and UMG 96RM-CBM

Parameter

Address	Format	RD/WR	Unit	Note	Adjustment Area	Default
10082	SHORT	RD		Condition digital output 3		
10083	SHORT	RD		Condition digital output 4		
10084	SHORT	RD		Condition digital output 5		
10085	SHORT	RD		Condition digital output 6		
10132	SHORT	RD		Status, digital input 1		
10133	SHORT	RD		Status, digital input 2		
10134	SHORT	RD		Status, digital input 3		
10135	SHORT	RD		Status, digital input 4		
10136	SHORT	RD		Status, overrange, I4		
10138	SHORT	RD		Status digital inputs 3-6 (Bit1=input 1,...)		
20001	UINT	RD/WR		Address of reading, UTC system time		
20003	UINT	RD/WR		Address of writing, UTC system time	0 .. 0xFFFFFFFF	0
20020	FLOAT	RD/WR		I4, nominal current	1 .. 1000000	150
20022	FLOAT	RD/WR		I4, current transformer, primary	0 .. 1000000	5
20024	FLOAT	RD/WR		I4, current transformer, secondary	1 .. 5	5
21992	FLOAT	RD/WR		S0 pulse valence, input 1	0 .. 1000000	0
21994	FLOAT	RD/WR		S0 pulse valence, input 2	0 .. 1000000	0
21996	FLOAT	RD/WR		S0 pulse valence, input 3	0 .. 1000000	0
21998	FLOAT	RD/WR		S0 pulse valence, input 4	0 .. 1000000	0
22000	SHORT	RD/WR		Measured value address output 3	0 .. 32000	0
22001	SHORT	RD/WR		Measured value address output 4	0 .. 32000	0
22002	SHORT	RD/WR		Measured value address output 5	0 .. 32000	0
22003	SHORT	RD/WR		Measured value address output 6	0 .. 32000	0
22004	FLOAT	RD/WR		Pulse valence, output 3	-1000000 .. +1000000	0
22006	FLOAT	RD/WR		Pulse valence, output 4	-1000000 .. +1000000	0
22008	FLOAT	RD/WR		Pulse valence, output 5	-1000000 .. +1000000	0
22010	FLOAT	RD/WR		Pulse valence, output 6	-1000000 .. +1000000	0
22096	SHORT	RD/WR		Output 3, Modbus remote, address	0, 1	0
22097	SHORT	RD/WR		Output 3, Profibus remote, address	0, 1	0
22098	SHORT	RD/WR		Output 4, Modbus remote, address	0, 1	0
22099	SHORT	RD/WR		Output 3, Profibus remote, address	0, 1	0
22100	SHORT	RD/WR		Output 5, Modbus remote, address	0, 1	0
22101	SHORT	RD/WR		Output 5, Profibus remote, address	0, 1	0
22102	SHORT	RD/WR		Output 6, Modbus remote, address	0, 1	0
22103	SHORT	RD/WR		Output 6, Profibus remote, address	0, 1	0
22500	CHAR	RD/WR		Rate 1, active energy, if input 1 is active	0,1	0
22501	CHAR	RD/WR		Rate 2, active energy, if input 2 is active	0,1	0
22502	CHAR	RD/WR		Rate 3, active energy, if input 3 is active	0,1	0
22503	CHAR	RD/WR		Rate 4, active energy, if input 4 is active	0,1	0
22507	CHAR	RD/WR		Rate 1, active energy, consumed, if input 1 is active	0,1	0
22508	CHAR	RD/WR		Rate 2, active energy, consumed, if input 2 is active	0,1	0
22509	CHAR	RD/WR		Rate 3, active energy, consumed, if input 3 is active	0,1	0
22510	CHAR	RD/WR		Rate 4, active energy, consumed, if input 4 is active	0,1	0
22514	CHAR	RD/WR		Rate 1, active energy, delivered, if input 1 is active	0,1	0
22515	CHAR	RD/WR		Rate 2, active energy, delivered, if input 2 is active	0,1	0
22516	CHAR	RD/WR		Rate 3, active energy, delivered, if input 3 is active	0,1	0
22517	CHAR	RD/WR		Rate 4, active energy, delivered, if input 4 is active	0,1	0

Address	Format	RD/WR	Unit	Note	Adjustment Area	Default
22521	CHAR	RD/WR		Rate 1, reactive energy, without reverse running stop, if input 1 is active	0,1	0
22522	CHAR	RD/WR		Rate 2, reactive energy, without reverse running stop, if input 2 is active	0,1	0
22523	CHAR	RD/WR		Rate 3, reactive energy, without reverse running stop, if input 3 is active	0,1	0
22524	CHAR	RD/WR		Rate 4, reactive energy, without reverse running stop, if input 4 is active	0,1	0
22528	CHAR	RD/WR		Rate 1, reactive energy induktiv, if input 1 is active	0,1	0
22529	CHAR	RD/WR		Rate 2, reactive energy induktiv, if input 2 is active	0,1	0
22530	CHAR	RD/WR		Rate 3, reactive energy induktiv, if input 3 is active	0,1	0
22531	CHAR	RD/WR		Rate 4, reactive energy induktiv, if input 4 is active	0,1	0
22535	CHAR	RD/WR		Rate 1, reactive energy kapazitiv, if input 1 is active	0,1	0
22536	CHAR	RD/WR		Rate 2, reactive energy kapazitiv, if input 2 is active	0,1	0
22537	CHAR	RD/WR		Rate 3, reactive energy kapazitiv, if input 3 is active	0,1	0
22538	CHAR	RD/WR		Rate 4, reactive energy kapazitiv, if input 4 is active	0,1	0
22542	CHAR	RD/WR		Rate 1, apparent energy, if input 1 is active	0,1	0
22543	CHAR	RD/WR		Rate 2, apparent energy, if input 2 is active	0,1	0
22544	CHAR	RD/WR		Rate 3, apparent energy, if input 3 is active	0,1	0
22545	CHAR	RD/WR		Rate 4, apparent energy, if input 4 is active	0,1	0
25010	SHORT	RD		Software release	-	-
25011	USHORT	RD		Hardware release	-	-
25012	SERNR	RD		Serial number	-	-

Limit value monitoring

Address	Format	RD/WR	Unit	Note	Adjustment Area	Default
10086	SHORT	RD		Results of the comparator A, comparator group 3		
10087	SHORT	RD		Results of the comparator B, comparator group 3		
10088	SHORT	RD		Results of the comparator C, comparator group 3		
10089	SHORT	RD		Results of the comparator A, comparator group 4		
10090	SHORT	RD		Results of the comparator B, comparator group 4		
10091	SHORT	RD		Results of the comparator C, comparator group 4		
10092	SHORT	RD		Results of the comparator A, comparator group 5		
10093	SHORT	RD		Results of the comparator B, comparator group 5		
10094	SHORT	RD		Results of the comparator C, comparator group 5		
10095	SHORT	RD		Results of the comparator A, comparator group 6		
10096	SHORT	RD		Results of the comparator B, comparator group 6		
10097	SHORT	RD		Results of the comparator C, comparator group 6		
10098	SHORT	RD	-	Comparator group 3, Linkage result of comparator group		
10099	SHORT	RD	-	Comparator group 4, Linkage result of comparator group		
10100	SHORT	RD	-	Comparator group 5, Linkage result of comparator group		
10101	SHORT	RD	-	Comparator group 6, Linkage result of comparator group		
10154	CONF_DB	RD	sec	Total running time, comparator A, comparator group 3		
10156	CONF_DB	RD	sec	Total running time, comparator B, comparator group 3		
10158	CONF_DB	RD	sec	Total running time, comparator C, comparator group 3		
10160	CONF_DB	RD	sec	Total running time, comparator A, comparator group 4		
10162	CONF_DB	RD	sec	Total running time, comparator B, comparator group 4		
10164	CONF_DB	RD	sec	Total running time, comparator C, comparator group 4		
10166	CONF_DB	RD	sec	Total running time, comparator A, comparator group 5		
10168	CONF_DB	RD	sec	Total running time, comparator B, comparator group 5		
10170	CONF_DB	RD	sec	Total running time, comparator C, comparator group 5		
10172	CONF_DB	RD	sec	Total running time, comparator A, comparator group 6		
10174	CONF_DB	RD	sec	Total running time, comparator B, comparator group 6		
10176	CONF_DB	RD	sec	Total running time, comparator C, comparator group 6		
10178	INT	RD	sec	Total running time, comparator A, comparator group 3		
10180	INT	RD	sec	Total running time, comparator B, comparator group 3		
10182	INT	RD	sec	Total running time, comparator C, comparator group 3		
10184	INT	RD	sec	Total running time, comparator A, comparator group 4		
10186	INT	RD	sec	Total running time, comparator B, comparator group 4		
10188	INT	RD	sec	Total running time, comparator C, comparator group 4		
10190	INT	RD	sec	Total running time, comparator A, comparator group 5		
10192	INT	RD	sec	Total running time, comparator B, comparator group 5		
10194	INT	RD	sec	Total running time, comparator C, comparator group 5		
10196	INT	RD	sec	Total running time, comparator A, comparator group 6		
10198	INT	RD	sec	Total running time, comparator B, comparator group 6		
10200	INT	RD	sec	Total running time, comparator C, comparator group 6		
22012	SHORT	RD/WR		Results of the comparator group 3 Combine A, B, C	0, 1	0
22013	FLOAT	RD/WR		Comparator 3A, limit	$-10^{12}-1..+10^{12}-1$	0
22015	SHORT	RD/WR		Comparator 3A, Address of measurement value	0 .. 32000	0
22016	SHORT	RD/WR		Comparator 3A, min. on time	0 .. 32000	0
22017	SHORT	RD/WR		Comparator 3A, lead time	0 .. 32000	0
22018	SHORT	RD/WR		Comparator 3A, inverted	0, 1	0
22019	FLOAT	RD/WR		Comparator 3B, limit	$-10^{12}-1..+10^{12}-1$	0
22021	SHORT	RD/WR		Comparator 3B, Address of measurement value	0 .. 32000	0
22022	SHORT	RD/WR		Comparator 3B, min. on time	0 .. 32000	0
22023	SHORT	RD/WR		Comparator 3B, lead time	0 .. 32000	0
22024	SHORT	RD/WR		Comparator 3B, inverted	0, 1	0
22025	FLOAT	RD/WR		Comparator 3C, limit	$-10^{12}-1..+10^{12}-1$	0
22027	SHORT	RD/WR		Comparator 3C, Address of measurement value	0 .. 32000	0
22028	SHORT	RD/WR		Comparator 3C, min. on time	0 .. 32000	0

Address	Format	RD/WR	Unit	Note	Adjustment Area	Default
22029	SHORT	RD/WR		Comparator 3C, lead time	0 .. 32000	0
22030	SHORT	RD/WR		Comparator 3C, inverted	0, 1	0
22031	SHORT	RD/WR		Results of the comparator group 4 Combine A, B, C	0, 1	0
22032	FLOAT	RD/WR		Comparator 4A, limit	$-10^{12}-1..+10^{12}-1$	0
22034	SHORT	RD/WR		Comparator 4A, Address of measurement value	0 .. 32000	0
22035	SHORT	RD/WR		Comparator 4A, min. on time	0 .. 32000	0
22036	SHORT	RD/WR		Comparator 4A, lead time	0 .. 32000	0
22037	SHORT	RD/WR		Comparator 4A, inverted	0, 1	0
22038	FLOAT	RD/WR		Comparator 4B, limit	$-10^{12}-1..+10^{12}-1$	0
22040	SHORT	RD/WR		Comparator 4B, Address of measurement value	0 .. 32000	0
22041	SHORT	RD/WR		Comparator 4B, min. on time	0 .. 32000	0
22042	SHORT	RD/WR		Comparator 4B, lead time	0 .. 32000	0
22043	SHORT	RD/WR		Comparator 4B, inverted	0, 1	0
22044	FLOAT	RD/WR		Comparator 4C, limit	$-10^{12}-1..+10^{12}-1$	0
22046	SHORT	RD/WR		Comparator 4C, Address of measurement value	0 .. 32000	0
22047	SHORT	RD/WR		Comparator 4C, min. on time	0 .. 32000	0
22048	SHORT	RD/WR		Comparator 4C, lead time	0 .. 32000	0
22049	SHORT	RD/WR		Comparator 4C, inverted	0, 1	0
22050	SHORT	RD/WR		Results of the comparator group 5 Combine A, B, C	0, 1	0
22051	FLOAT	RD/WR		Comparator 5A, limit	$-10^{12}-1..+10^{12}-1$	0
22053	SHORT	RD/WR		Comparator 5A, Address of measurement value	0 .. 32000	0
22054	SHORT	RD/WR		Comparator 5A, min. on time	0 .. 32000	0
22055	SHORT	RD/WR		Comparator 5A, lead time	0 .. 32000	0
22056	SHORT	RD/WR		Comparator 5A, inverted	0, 1	0
22057	FLOAT	RD/WR		Comparator 5B, limit	$-10^{12}-1..+10^{12}-1$	0
22059	SHORT	RD/WR		Comparator 5B, Address of measurement value	0 .. 32000	0
22060	SHORT	RD/WR		Comparator 5B, min. on time	0 .. 32000	0
22061	SHORT	RD/WR		Comparator 5B, lead time	0 .. 32000	0
22062	SHORT	RD/WR		Comparator 5B, inverted	0, 1	0
22063	FLOAT	RD/WR		Comparator 5C, limit	$-10^{12}-1..+10^{12}-1$	0
22065	SHORT	RD/WR		Comparator 5C, Address of measurement value	0 .. 32000	0
22066	SHORT	RD/WR		Comparator 5C, min. on time	0 .. 32000	0
22067	SHORT	RD/WR		Comparator 5C, lead time	0 .. 32000	0
22068	SHORT	RD/WR		Comparator 5C, inverted	0, 1	0
22069	SHORT	RD/WR		Results of the comparator group 6 Combine A, B, C	0, 1	0
22070	FLOAT	RD/WR		Comparator 6A, limit	$-10^{12}-1..+10^{12}-1$	0
22072	SHORT	RD/WR		Comparator 6A, Address of measurement value	0 .. 32000	0
22073	SHORT	RD/WR		Comparator 6A, min. on time	0 .. 32000	0
22074	SHORT	RD/WR		Comparator 6A, lead time	0 .. 32000	0
22075	SHORT	RD/WR		Comparator 6A, inverted	0, 1	0
22076	FLOAT	RD/WR		Comparator 6B, limit	$-10^{12}-1..+10^{12}-1$	0
22078	SHORT	RD/WR		Comparator 6B, Address of measurement value	0 .. 32000	0
22079	SHORT	RD/WR		Comparator 6B, min. on time	0 .. 32000	0
22080	SHORT	RD/WR		Comparator 6B, lead time	0 .. 32000	0
22081	SHORT	RD/WR		Comparator 6B, inverted	0, 1	0
22082	FLOAT	RD/WR		Comparator 6C, limit	$-10^{12}-1..+10^{12}-1$	0
22084	SHORT	RD/WR		Comparator 6C, Address of measurement value	0 .. 32000	0
22085	SHORT	RD/WR		Comparator 6C, min. on time	0 .. 32000	0
22086	SHORT	RD/WR		Comparator 6C, lead time	0 .. 32000	0
22087	SHORT	RD/WR		Comparator 6C, inverted	0, 1	0

Address	Format	RD/WR	Unit	Note	Index	
22088	SHORT	RD/WR		Source selection for digital output 3 0 = Comparator 3 1 = Pulse output (S0) 2 = External source - Modbus 3 = External source - Profibus (option) 4 = External source - Ethernet (option)	0 .. 4	0
22089	SHORT	RD/WR		Output 3 inverted	0, 1	0
22090	SHORT	RD/WR		Source selection for digital output 4 0 = Comparator 3 1 = Pulse output (S0) 2 = External source - Modbus 3 = External source - Profibus (option) 4 = External source - Ethernet (option)	0 .. 4	0
22091	SHORT	RD/WR		Output 4 inverted	0, 1	0
22092	SHORT	RD/WR		Source selection for digital output 5 0 = Comparator 3 1 = Pulse output (S0) 2 = External source - Modbus 3 = External source - Profibus (option) 4 = External source - Ethernet (option)	0 .. 4	0
22093	SHORT	RD/WR		Output 5 inverted	0, 1	0
22094	SHORT	RD/WR		Source selection for digital output 6 0 = Comparator 3 1 = Pulse output (S0) 2 = External source - Modbus 3 = External source - Profibus (option) 4 = External source - Ethernet (option)	0 .. 4	0
22095	SHORT	RD/WR		Output 6 inverted	0, 1	0

Address	Format	RD/WR	Unit	Note	Index
---------	--------	-------	------	------	-------

Measured values, type float

Address	Format	RD/WR	Unit	Note	Index
10102	FLOAT	RD	A	I4, effective value	
10104	FLOAT	RD	%	I4, THD	
10106	FLOAT	RD	%	I4, TDD	
10108	FLOAT	RD		Pulse input 1, power	
10110	FLOAT	RD		Pulse input 2, power	
10112	FLOAT	RD		Pulse input 3, power	
10114	FLOAT	RD		Pulse input 4, power	

Measured values, type short

The measured values in short format do not contain current and voltage transformer ratios.

Address	Format	RD/WR	Unit	Note	Index	Resolution
10620	SHORT	RD	mA	I4 current		1
10621	SHORT	RD	%	I4 current, THD		0,1
10622	SHORT	RD	%	I4 current, TDD		0,1
10623	SHORT	RD		Pulse input 1, power		
10624	SHORT	RD		Pulse input 2, power		
10625	SHORT	RD		Pulse input 3, power		
10626	SHORT	RD		Pulse input 4, power		

Measured values, type integer

Address	Format	RD/WR	Unit	Note	Index
10202	UINT	RD	n	Meter reading, pulse meter, digital input 1	
10204	UINT	RD	n	Meter reading, pulse meter, digital input 2	
10206	UINT	RD	n	Meter reading, pulse meter, digital input 3	
10208	UINT	RD	n	Meter reading, pulse meter, digital input 4	

Mean values, type float

Address	Format	RD/WR	Unit	Note	Index
10116	FLOAT	RD		Pulse input 1, power, average	
10118	FLOAT	RD		Pulse input 2, power, average	
10120	FLOAT	RD		Pulse input 3, power, average	
10122	FLOAT	RD		Pulse input 4, power, average	
10140	FLOAT	RD	A	I4 current, average	
10142	FLOAT	RD	%	I4 current, average, THD	
10144	FLOAT	RD	%	I4 current, average, TDD	

Mean values, type short

The measured values in short format do not contain current and voltage transformer ratios.

Address	Format	RD/WR	Unit	Note	Index	Resolution
10667	SHORT	RD	mA	I4 current, average		1
10668	SHORT	RD	%	I4 current, average, THD		0,1
10669	SHORT	RD	%	I4 current, average, TDD		0,1
10670	SHORT	RD		Pulse input 1, power, average		
10671	SHORT	RD		Pulse input 2, power, average		
10672	SHORT	RD		Pulse input 3, power, average		
10673	SHORT	RD		Pulse input 4, power, average		

Maximum values, type float

Address	Format	RD/WR	Unit	Note	Index
10124	FLOAT	RD		Pulse input 1, power, max. value	
10126	FLOAT	RD		Pulse input 2, power, max. value	
10128	FLOAT	RD		Pulse input 3, power, max. value	
10130	FLOAT	RD		Pulse input 4, power, max. value	
10146	FLOAT	RD	A	I4, max. value	
10148	FLOAT	RD	%	I4, THD, max. value	
10150	FLOAT	RD	%	I4, TDD, max. value	
10152	FLOAT	RD	A	I4, max. value of average value	

Maximum values, type short

The measured values in short format do not contain current and voltage transformer ratios.

Adresse	Format	RD/WR	Einheit	Bemerkung	Index	Resolution
10714	SHORT	RD	mA	I4 current, max. value		1
10715	SHORT	RD	%	I4 current, THD, max. value		0,1
10716	SHORT	RD	%	I4 current, TDD, max. value		0,1
10717	SHORT	RD		Pulse input 1, power, max. value		
10718	SHORT	RD		Pulse input 2, power, max. value		
10719	SHORT	RD		Pulse input 3, power, max. value		
10720	SHORT	RD		Pulse input 4, power, max. value		
10761	SHORT	RD	A	I4 current, max. value of average value		

Minimum values, time stamp

Address	Format	RD/WR	Unit	Note	Index
10398	INT	RD	s	Time of min. value (UTC), frequency	
10400	INT	RD	s	Time of min. value (UTC), Voltage zero sequence	
10402	INT	RD	s	Time of min. value (UTC), Voltage negative sequence	
10404	INT	RD	s	Time of min. value (UTC), Voltage positive sequence	
10406	INT	RD	s	Time of min. value (UTC), voltage U L1-N	
10408	INT	RD	s	Time of min. value (UTC), voltage U L2-N	
10410	INT	RD	s	Time of min. value (UTC), voltage U L3-N	
10412	INT	RD	s	Time of min. value (UTC), voltage U L1-L2	
10414	INT	RD	s	Time of min. value (UTC), voltage U L2-L3	
10416	INT	RD	s	Time of min. value (UTC), voltage U L3-12	
10418	INT	RD	s	Time of min. value (UTC), powerfactor fund. L1	
10420	INT	RD	s	Time of min. value (UTC), powerfactor fund. L2	
10422	INT	RD	s	Time of min. value (UTC), powerfactor fund. L3	
10424	INT	RD	s	Time of min. value (UTC), powerfactor fund. Summe	
10426	INT	RD	s	Time of min. value (UTC), powerfactor L1	
10428	INT	RD	s	Time of min. value (UTC), powerfactor L2	
10430	INT	RD	s	Time of min. value (UTC), powerfactor L3	
10432	INT	RD	s	Time of min. value (UTC), powerfactor Summe	
10434	INT	RD	s	Time of min. value (UTC), THD U L1-N	
10436	INT	RD	s	Time of min. value (UTC), THD U L2-N	
10438	INT	RD	s	Time of min. value (UTC), THD U L3-N	
10440	INT	RD	s	Time of min. value (UTC), THD U L1-UL2	
10442	INT	RD	s	Time of min. value (UTC), THD U L2-UL3	
10444	INT	RD	s	Time of min. value (UTC), THD U L3-UL1	
10446	INT	RD	s	Time of min. value (UTC), voltage U L1-N	
10448	INT	RD	s	Time of min. value (UTC), voltage U L2-N	
10450	INT	RD	s	Time of min. value (UTC), voltage U L3-N	
10452	INT	RD	s	Time of min. value (UTC), voltage U L1-L2	
10454	INT	RD	s	Time of min. value (UTC), voltage U L2-L3	
10456	INT	RD	s	Time of min. value (UTC), voltage U L3-12	

Maximum values, time stamp

Address	Format	RD/WR	Unit	Note	Index
10210	INT	RD	s	Time of max. value (UTC), I4	
10212	INT	RD	s	Time of max. value (UTC), I4 THD	
10214	INT	RD	s	Time of max. value (UTC), I4 TDD	
10216	INT	RD	s	Time of max. value (UTC) of average value, I4	
10218	INT	RD	s	Time of max. value (UTC), pulse input 3	
10220	INT	RD	s	Time of max. value (UTC), pulse input 4	
10222	INT	RD	s	Time of max. value (UTC), pulse input 5	
10224	INT	RD	s	Time of max. value (UTC), pulse input 6	
10226	INT	RD	s	Time of max. value (UTC), frequency	
10228	INT	RD	s	Time of max. value (UTC), Voltage zero sequence	
10230	INT	RD	s	Time of max. value (UTC), Voltage negative sequence	
10232	INT	RD	s	Time of max. value (UTC), Voltage positive sequence	
10234	INT	RD	s	Time of max. value (UTC), voltage U L1-N	
10236	INT	RD	s	Time of max. value (UTC), voltage U L2-N	
10238	INT	RD	s	Time of max. value (UTC), voltage U L3-N	
10240	INT	RD	s	Time of max. value (UTC), voltage U L1-L2	
10242	INT	RD	s	Time of max. value (UTC), voltage U L2-L3	
10244	INT	RD	s	Time of max. value (UTC), voltage U L3-12	
10246	INT	RD	s	Time of max. value (UTC), powerfactor fund. L1	
10248	INT	RD	s	Time of max. value (UTC), powerfactor fund. L2	
10250	INT	RD	s	Time of max. value (UTC), powerfactor fund. L3	
10252	INT	RD	s	Time of max. value (UTC), powerfactor fund. sum	
10254	INT	RD	s	Time of max. value (UTC), powerfactor L1	
10256	INT	RD	s	Time of max. value (UTC), powerfactor L2	
10258	INT	RD	s	Time of max. value (UTC), powerfactor L3	
10260	INT	RD	s	Time of max. value (UTC), powerfactor sum	
10262	INT	RD	s	Time of max. value (UTC), THD U L1-N	
10264	INT	RD	s	Time of max. value (UTC), THD U L2-N	
10266	INT	RD	s	Time of max. value (UTC), THD U L3-N	
10268	INT	RD	s	Time of max. value (UTC), THD U L1-UL2	
10270	INT	RD	s	Time of max. value (UTC), THD U L2-UL3	
10272	INT	RD	s	Time of max. value (UTC), THD U L3-UL1	
10292	INT	RD	s	Time of max. value (UTC)e, real part, U L1-N	
10294	INT	RD	s	Time of max. value (UTC)e, real part, U L2-N	
10296	INT	RD	s	Time of max. value (UTC)e, real part, U L3-N	
10298	INT	RD	s	Time of max. value (UTC)e, imaginary part, U L1-N	
10300	INT	RD	s	Time of max. value (UTC)e, imaginary part, U L2-N	
10302	INT	RD	s	Time of max. value (UTC)e, imaginary part, U L3-N	
10304	INT	RD	s	Time of max. value (UTC)e, current, I1	
10306	INT	RD	s	Time of max. value (UTC)e, current, I2	
10308	INT	RD	s	Time of max. value (UTC)e, current, I3	
10310	INT	RD	s	Time of max. value (UTC)e, current N (sum I1..I3)	
10312	INT	RD	s	Time of max. value (UTC)e, active power, P1	
10314	INT	RD	s	Time of max. value (UTC)e, active power, P2	
10316	INT	RD	s	Time of max. value (UTC)e, active power, P3	
10318	INT	RD	s	Time of max. value (UTC)e, active power, P sum	
10320	INT	RD	s	Time of max. value (UTC)e, reactive power, Q1	
10322	INT	RD	s	Time of max. value (UTC)e, reactive power, Q1	
10324	INT	RD	s	Time of max. value (UTC)e, reactive power, Q1	
10326	INT	RD	s	Time of max. value (UTC)e, reactive power, Q sum	
10328	INT	RD	s	Time of max. value (UTC)e, apparent power, Q1	
10330	INT	RD	s	Time of max. value (UTC)e, apparent power, Q1	
10332	INT	RD	s	Time of max. value (UTC)e, apparent power, Q1	
10334	INT	RD	s	Time of max. value (UTC)e, apparent power, Q sum	
10336	INT	RD	s	Time of max. value (UTC)e, active power, fund., P1	
10338	INT	RD	s	Time of max. value (UTC)e, active power, fund., P2	
10340	INT	RD	s	Time of max. value (UTC)e, active power, fund., P3	
10342	INT	RD	s	Time of max. value (UTC)e, active power, fund., P sum	
10344	INT	RD	s	Time of max. value (UTC), harmonic distortion power D L1-N	
10346	INT	RD	s	Time of max. value (UTC), harmonic distortion power D L2-N	
10348	INT	RD	s	Time of max. value (UTC), harmonic distortion power D L3-N	
10350	INT	RD	s	Time of max. value (UTC), sum; Dsum3=D1+D2+D3	

Address	Format	RD/WR	Unit	Note	Index
10352	INT	RD	s	Time of max. value (UTC), THD I1	
10354	INT	RD	s	Time of max. value (UTC), THD I2	
10356	INT	RD	s	Time of max. value (UTC), THD I3	
10358	INT	RD	s	Time of max. value (UTC), TDD I1	
10360	INT	RD	s	Time of max. value (UTC), TDD I2	
10362	INT	RD	s	Time of max. value (UTC), TDD I3	
10364	INT	RD	s	Time of max. value (UTC), Current zero sequence	
10366	INT	RD	s	Time of max. value (UTC), Current negative sequence	
10368	INT	RD	s	Time of max. value (UTC), Current positive sequence	
10370	INT	RD	s	Time of max. value (UTC), real part I1	
10372	INT	RD	s	Time of max. value (UTC), real part I2	
10374	INT	RD	s	Time of max. value (UTC), real part I3	
10376	INT	RD	s	Time of max. value (UTC), imaginary part I1	
10378	INT	RD	s	Time of max. value (UTC), imaginary part I2	
10380	INT	RD	s	Time of max. value (UTC), imaginary part I3	
10382	INT	RD	s	Time of max. value (UTC) of average value I1	
10384	INT	RD	s	Time of max. value (UTC) of average value I2	
10386	INT	RD	s	Time of max. value (UTC) of average value I3	
10388	INT	RD	s	Time of max. value (UTC) of average value N (sum I1..I3)	
10390	INT	RD	s	Time of max. value (UTC) of average value P1	
10392	INT	RD	s	Time of max. value (UTC) of average value P2	
10394	INT	RD	s	Time of max. value (UTC) of average value P3	
10396	INT	RD	s	Time of max. value (UTC) of average value P sum	

Peak indicator (drag indicator)

Address	Format	RD/WR	Unit	Note	Index
5974	FLOAT	RD		Current I L1; highest value	
5976	FLOAT	RD		Current I L2; highest value	
5978	FLOAT	RD		Current I L3; highest value	
5986	FLOAT	RD		Apparent power S1 L1N; highest value	
5988	FLOAT	RD		Apparent power S2 L2N; highest value	
5990	FLOAT	RD		Apparent power S3 L3N; highest value	
5992	FLOAT	RD		Apparent power; Sum; Ssum3=S1+S2+S3; highest value	
6002	FLOAT	RD		Real power P1 L1N (positiv); highest value	
6004	FLOAT	RD		Real power P2 L2N (positiv); highest value	
6006	FLOAT	RD		Real power P3 L3N (positiv); highest value	
6008	FLOAT	RD		Real power (positiv); Sum; Psum3=P1+P2+P3; highest value	
6018	FLOAT	RD		Real power P1 L1N (negative); highest value	
6020	FLOAT	RD		Real power P2 L2N (negative); highest value	
6022	FLOAT	RD		Real power P3 L3N (negative); highest value	
6024	FLOAT	RD		Real power (negative) Sum; Psum3=P1+P2+P3; highest value	
6034	FLOAT	RD		Current I L1; second highest value	
6036	FLOAT	RD		Current I L2; second highest value	
6038	FLOAT	RD		Current I L3; second highest value	
6046	FLOAT	RD		Apparent power S1 L1N; second highest value	
6048	FLOAT	RD		Apparent power S2 L2N; second highest value	
6050	FLOAT	RD		Apparent power S3 L3N; second highest value	
6052	FLOAT	RD		Apparent power; Sum; Ssum3=S1+S2+S3; second highest value	
6062	FLOAT	RD		Real power P1 L1N (positiv); second highest value	
6064	FLOAT	RD		Real power P2 L2N (positiv); second highest value	
6066	FLOAT	RD		Real power P3 L3N (positiv); second highest value	
6068	FLOAT	RD		Real power (positiv); Sum; Psum3=P1+P2+P3; second highest value	
6078	FLOAT	RD		Real power P1 L1N (negative); second highest value	
6080	FLOAT	RD		Real power P2 L2N (negative); second highest value	
6082	FLOAT	RD		Real power P3 L3N (negative); second highest value	
6084	FLOAT	RD		Real power (negative) Sum; Psum3=P1+P2+P3; second highest value	
6094	FLOAT	RD		Current I L1; third highest value	
6096	FLOAT	RD		Current I L2; third highest value	
6098	FLOAT	RD		Current I L3; third highest value	
6106	FLOAT	RD		Apparent power S1 L1N; third highest value	
6108	FLOAT	RD		Apparent power S2 L2N; third highest value	
6110	FLOAT	RD		Apparent power S3 L3N; third highest value	
6112	FLOAT	RD		Apparent power; Sum; Ssum3=S1+S2+S3; third highest value	
6122	FLOAT	RD		Real power P1 L1N (positiv); third highest value	
6124	FLOAT	RD		Real power P2 L2N (positiv); third highest value	
6126	FLOAT	RD		Real power P3 L3N (positiv); third highest value	
6128	FLOAT	RD		Real power (positiv); Sum; Psum3=P1+P2+P3; third highest value	
6138	FLOAT	RD		Real power P1 L1N (negative); third highest value	
6140	FLOAT	RD		Real power P2 L2N (negative); third highest value	
6142	FLOAT	RD		Real power P3 L3N (negative); third highest value	
6144	FLOAT	RD		Real power (negative) Sum; Psum3=P1+P2+P3; third highest value	
5980	UINT	RD		Time of Current I L1; highest value	
5982	UINT	RD		Time of Current I L2; highest value	
5984	UINT	RD		Time of Current I L3; highest value	
5994	UINT	RD		Time of Apparent power S1 L1N; highest value	
5996	UINT	RD		Time of Apparent power S2 L2N; highest value	
5998	UINT	RD		Time of Apparent power S3 L3N; highest value	
6000	UINT	RD		Time of Apparent power; Sum; Ssum3=S1+S2+S3; highest value	
6010	UINT	RD		Time of Real power P1 L1N (positiv); highest value	
6012	UINT	RD		Time of Real power P2 L2N (positiv); highest value	
6014	UINT	RD		Time of Real power P3 L3N (positiv); highest value	
6016	UINT	RD		Time of Real power (positiv); Sum; Psum3=P1+P2+P3; highest value	
6026	UINT	RD		Time of Real power P1 L1N (negative); highest value	
6028	UINT	RD		Time of Real power P2 L2N (negative); highest value	
6030	UINT	RD		Time of Real power P3 L3N (negative); highest value	
6032	UINT	RD		Time of Real power (negative) Sum; Psum3=P1+P2+P3; highest value	
6040	UINT	RD		Time of Current I L1; second highest value	
6042	UINT	RD		Time of Current I L2; second highest value	

Address	Format	RD/WR	Unit	Note	Index
6044	UINT	RD		Time of Current I L3; second highest value	
6054	UINT	RD		Time of Apparent power S1 L1N; second highest value	
6056	UINT	RD		Time of Apparent power S2 L2N; second highest value	
6058	UINT	RD		Time of Apparent power S3 L3N; second highest value	
6060	UINT	RD		Time of Apparent power; Sum; Ssum3=S1+S2+S3; second highest value	
6070	UINT	RD		Time of Real power P1 L1N (positiv); second highest value	
6072	UINT	RD		Time of Real power P2 L2N (positiv); second highest value	
6074	UINT	RD		Time of Real power P3 L3N (positiv); second highest value	
6076	UINT	RD		Time of Real power (positiv); Sum; Psum3=P1+P2+P3; second highest value	
6086	UINT	RD		Time of Real power P1 L1N (negative); second highest value	
6088	UINT	RD		Time of Real power P2 L2N (negative); second highest value	
6090	UINT	RD		Time of Real power P3 L3N (negative); second highest value	
6092	UINT	RD		Time of Real power (negative) Sum; Psum3=P1+P2+P3; second highest value	
6100	UINT	RD		Time of Current I L1; third highest value	
6102	UINT	RD		Time of Current I L2; third highest value	
6104	UINT	RD		Time of Current I L3; third highest value	
6114	UINT	RD		Time of Apparent power S1 L1N; third highest value	
6116	UINT	RD		Time of Apparent power S2 L2N; third highest value	
6118	UINT	RD		Time of Apparent power S3 L3N; third highest value	
6120	UINT	RD		Time of Apparent power; Sum; Ssum3=S1+S2+S3; third highest value	
6130	UINT	RD		Time of Real power P1 L1N (positiv); third highest value	
6132	UINT	RD		Time of Real power P2 L2N (positiv); third highest value	
6134	UINT	RD		Time of Real power P3 L3N (positiv); third highest value	
6136	UINT	RD		Time of Real power (positiv); Sum; Psum3=P1+P2+P3; third highest value	
6146	UINT	RD		Time of Real power P1 L1N (negative); third highest value	
6148	UINT	RD		Time of Real power P2 L2N (negative); third highest value	
6150	UINT	RD		Time of Real power P3 L3N (negative); third highest value	
6152	UINT	RD		Time of Real power (negative) Sum; Psum3=P1+P2+P3; third highest value	

Fourier analysis

Measured values, typ float, fourier analysis

Address	Format	RD/WR	Unit	Note	Index
10000	FLOAT	RD	A	Harmonic I L4	[0]
10002	FLOAT	RD	A	Harmonic I L4	[1]
10004	FLOAT	RD	A	Harmonic I L4	[2]
10006	FLOAT	RD	A	Harmonic I L4	[3]
10008	FLOAT	RD	A	Harmonic I L4	[4]
10010	FLOAT	RD	A	Harmonic I L4	[5]
10012	FLOAT	RD	A	Harmonic I L4	[6]
10014	FLOAT	RD	A	Harmonic I L4	[7]
10016	FLOAT	RD	A	Harmonic I L4	[8]
10018	FLOAT	RD	A	Harmonic I L4	[9]
10020	FLOAT	RD	A	Harmonic I L4	[10]
10022	FLOAT	RD	A	Harmonic I L4	[11]
10024	FLOAT	RD	A	Harmonic I L4	[12]
10026	FLOAT	RD	A	Harmonic I L4	[13]
10028	FLOAT	RD	A	Harmonic I L4	[14]
10030	FLOAT	RD	A	Harmonic I L4	[15]
10032	FLOAT	RD	A	Harmonic I L4	[16]
10034	FLOAT	RD	A	Harmonic I L4	[17]
10036	FLOAT	RD	A	Harmonic I L4	[18]
10038	FLOAT	RD	A	Harmonic I L4	[19]
10040	FLOAT	RD	A	Harmonic I L4	[20]
10042	FLOAT	RD	A	Harmonic I L4	[21]
10044	FLOAT	RD	A	Harmonic I L4	[22]
10046	FLOAT	RD	A	Harmonic I L4	[23]
10048	FLOAT	RD	A	Harmonic I L4	[24]
10050	FLOAT	RD	A	Harmonic I L4	[25]
10052	FLOAT	RD	A	Harmonic I L4	[26]
10054	FLOAT	RD	A	Harmonic I L4	[27]
10056	FLOAT	RD	A	Harmonic I L4	[28]
10058	FLOAT	RD	A	Harmonic I L4	[29]
10060	FLOAT	RD	A	Harmonic I L4	[30]
10062	FLOAT	RD	A	Harmonic I L4	[31]
10064	FLOAT	RD	A	Harmonic I L4	[32]
10066	FLOAT	RD	A	Harmonic I L4	[33]
10068	FLOAT	RD	A	Harmonic I L4	[34]
10070	FLOAT	RD	A	Harmonic I L4	[35]
10072	FLOAT	RD	A	Harmonic I L4	[36]
10074	FLOAT	RD	A	Harmonic I L4	[37]
10076	FLOAT	RD	A	Harmonic I L4	[38]
10078	FLOAT	RD	A	Harmonic I L4	[39]

Measured values, typ short, fourier analysis

The measured values in short format do not contain current and voltage transformer ratios.

Address	Format	RD/WR	Unit	Note	Index	Resolution
10627	SHORT	RD	mA	Harmonic I L4	[0]	1
10628	SHORT	RD	mA	Harmonic I L4	[1]	1
10629	SHORT	RD	mA	Harmonic I L4	[2]	1
10630	SHORT	RD	mA	Harmonic I L4	[3]	1
10631	SHORT	RD	mA	Harmonic I L4	[4]	1
10632	SHORT	RD	mA	Harmonic I L4	[5]	1
10633	SHORT	RD	mA	Harmonic I L4	[6]	1
10634	SHORT	RD	mA	Harmonic I L4	[7]	1
10635	SHORT	RD	mA	Harmonic I L4	[8]	1
10636	SHORT	RD	mA	Harmonic I L4	[9]	1
10637	SHORT	RD	mA	Harmonic I L4	[10]	1
10638	SHORT	RD	mA	Harmonic I L4	[11]	1
10639	SHORT	RD	mA	Harmonic I L4	[12]	1
10640	SHORT	RD	mA	Harmonic I L4	[13]	1
10641	SHORT	RD	mA	Harmonic I L4	[14]	1
10642	SHORT	RD	mA	Harmonic I L4	[15]	1
10643	SHORT	RD	mA	Harmonic I L4	[16]	1
10644	SHORT	RD	mA	Harmonic I L4	[17]	1
10645	SHORT	RD	mA	Harmonic I L4	[18]	1
10646	SHORT	RD	mA	Harmonic I L4	[19]	1
10647	SHORT	RD	mA	Harmonic I L4	[20]	1
10648	SHORT	RD	mA	Harmonic I L4	[21]	1
10649	SHORT	RD	mA	Harmonic I L4	[22]	1
10650	SHORT	RD	mA	Harmonic I L4	[23]	1
10651	SHORT	RD	mA	Harmonic I L4	[24]	1
10652	SHORT	RD	mA	Harmonic I L4	[25]	1
10653	SHORT	RD	mA	Harmonic I L4	[26]	1
10654	SHORT	RD	mA	Harmonic I L4	[27]	1
10655	SHORT	RD	mA	Harmonic I L4	[28]	1
10656	SHORT	RD	mA	Harmonic I L4	[29]	1
10657	SHORT	RD	mA	Harmonic I L4	[30]	1
10658	SHORT	RD	mA	Harmonic I L4	[31]	1
10659	SHORT	RD	mA	Harmonic I L4	[32]	1
10660	SHORT	RD	mA	Harmonic I L4	[33]	1
10661	SHORT	RD	mA	Harmonic I L4	[34]	1
10662	SHORT	RD	mA	Harmonic I L4	[35]	1
10663	SHORT	RD	mA	Harmonic I L4	[36]	1
10664	SHORT	RD	mA	Harmonic I L4	[37]	1
10665	SHORT	RD	mA	Harmonic I L4	[38]	1
10666	SHORT	RD	mA	Harmonic I L4	[39]	1

Mean values, typ float, fourier analysis

Address	Format	RD/WR	Unit	Note	Index
10540	FLOAT	RD	A	Average, Harmonic I L4	[0]
10542	FLOAT	RD	A	Average, Harmonic I L4	[1]
10544	FLOAT	RD	A	Average, Harmonic I L4	[2]
10546	FLOAT	RD	A	Average, Harmonic I L4	[3]
10548	FLOAT	RD	A	Average, Harmonic I L4	[4]
10550	FLOAT	RD	A	Average, Harmonic I L4	[5]
10552	FLOAT	RD	A	Average, Harmonic I L4	[6]
10554	FLOAT	RD	A	Average, Harmonic I L4	[7]
10556	FLOAT	RD	A	Average, Harmonic I L4	[8]
10558	FLOAT	RD	A	Average, Harmonic I L4	[9]
10560	FLOAT	RD	A	Average, Harmonic I L4	[10]
10562	FLOAT	RD	A	Average, Harmonic I L4	[11]
10564	FLOAT	RD	A	Average, Harmonic I L4	[12]
10566	FLOAT	RD	A	Average, Harmonic I L4	[13]
10568	FLOAT	RD	A	Average, Harmonic I L4	[14]
10570	FLOAT	RD	A	Average, Harmonic I L4	[15]
10572	FLOAT	RD	A	Average, Harmonic I L4	[16]
10574	FLOAT	RD	A	Average, Harmonic I L4	[17]
10576	FLOAT	RD	A	Average, Harmonic I L4	[18]
10578	FLOAT	RD	A	Average, Harmonic I L4	[19]
10580	FLOAT	RD	A	Average, Harmonic I L4	[20]
10582	FLOAT	RD	A	Average, Harmonic I L4	[21]
10584	FLOAT	RD	A	Average, Harmonic I L4	[22]
10586	FLOAT	RD	A	Average, Harmonic I L4	[23]
10588	FLOAT	RD	A	Average, Harmonic I L4	[24]
10590	FLOAT	RD	A	Average, Harmonic I L4	[25]
10592	FLOAT	RD	A	Average, Harmonic I L4	[26]
10594	FLOAT	RD	A	Average, Harmonic I L4	[27]
10596	FLOAT	RD	A	Average, Harmonic I L4	[28]
10598	FLOAT	RD	A	Average, Harmonic I L4	[29]
10600	FLOAT	RD	A	Average, Harmonic I L4	[30]
10602	FLOAT	RD	A	Average, Harmonic I L4	[31]
10604	FLOAT	RD	A	Average, Harmonic I L4	[32]
10606	FLOAT	RD	A	Average, Harmonic I L4	[33]
10608	FLOAT	RD	A	Average, Harmonic I L4	[34]
10610	FLOAT	RD	A	Average, Harmonic I L4	[35]
10612	FLOAT	RD	A	Average, Harmonic I L4	[36]
10614	FLOAT	RD	A	Average, Harmonic I L4	[37]
10616	FLOAT	RD	A	Average, Harmonic I L4	[38]
10618	FLOAT	RD	A	Average, Harmonic I L4	[39]

Mean values, typ short, fourier analysis

The measured values in short format do not contain current and voltage transformer ratios.

Address	Format	RD/WR	Unit	Note	Index	Resolution
10674	SHORT	RD	mA	Average, Harmonic I L4	[0]	1
10675	SHORT	RD	mA	Average, Harmonic I L4	[1]	1
10676	SHORT	RD	mA	Average, Harmonic I L4	[2]	1
10677	SHORT	RD	mA	Average, Harmonic I L4	[3]	1
10678	SHORT	RD	mA	Average, Harmonic I L4	[4]	1
10679	SHORT	RD	mA	Average, Harmonic I L4	[5]	1
10680	SHORT	RD	mA	Average, Harmonic I L4	[6]	1
10681	SHORT	RD	mA	Average, Harmonic I L4	[7]	1
10682	SHORT	RD	mA	Average, Harmonic I L4	[8]	1
10683	SHORT	RD	mA	Average, Harmonic I L4	[9]	1
10684	SHORT	RD	mA	Average, Harmonic I L4	[10]	1
10685	SHORT	RD	mA	Average, Harmonic I L4	[11]	1
10686	SHORT	RD	mA	Average, Harmonic I L4	[12]	1
10687	SHORT	RD	mA	Average, Harmonic I L4	[13]	1
10688	SHORT	RD	mA	Average, Harmonic I L4	[14]	1
10689	SHORT	RD	mA	Average, Harmonic I L4	[15]	1
10690	SHORT	RD	mA	Average, Harmonic I L4	[16]	1
10691	SHORT	RD	mA	Average, Harmonic I L4	[17]	1
10692	SHORT	RD	mA	Average, Harmonic I L4	[18]	1
10693	SHORT	RD	mA	Average, Harmonic I L4	[19]	1
10694	SHORT	RD	mA	Average, Harmonic I L4	[20]	1
10695	SHORT	RD	mA	Average, Harmonic I L4	[21]	1
10696	SHORT	RD	mA	Average, Harmonic I L4	[22]	1
10697	SHORT	RD	mA	Average, Harmonic I L4	[23]	1
10698	SHORT	RD	mA	Average, Harmonic I L4	[24]	1
10699	SHORT	RD	mA	Average, Harmonic I L4	[25]	1
10700	SHORT	RD	mA	Average, Harmonic I L4	[26]	1
10701	SHORT	RD	mA	Average, Harmonic I L4	[27]	1
10702	SHORT	RD	mA	Average, Harmonic I L4	[28]	1
10703	SHORT	RD	mA	Average, Harmonic I L4	[29]	1
10704	SHORT	RD	mA	Average, Harmonic I L4	[30]	1
10705	SHORT	RD	mA	Average, Harmonic I L4	[31]	1
10706	SHORT	RD	mA	Average, Harmonic I L4	[32]	1
10707	SHORT	RD	mA	Average, Harmonic I L4	[33]	1
10708	SHORT	RD	mA	Average, Harmonic I L4	[34]	1
10709	SHORT	RD	mA	Average, Harmonic I L4	[35]	1
10710	SHORT	RD	mA	Average, Harmonic I L4	[36]	1
10711	SHORT	RD	mA	Average, Harmonic I L4	[37]	1
10712	SHORT	RD	mA	Average, Harmonic I L4	[38]	1
10713	SHORT	RD	mA	Average, Harmonic I L4	[39]	1

Maximum values, typ float, fourier analysis

Address	Format	RD/WR	Unit	Note	Index
10460	FLOAT	RD	A	Maximum, Harmonic I L4	[0]
10462	FLOAT	RD	A	Maximum, Harmonic I L4	[1]
10464	FLOAT	RD	A	Maximum, Harmonic I L4	[2]
10466	FLOAT	RD	A	Maximum, Harmonic I L4	[3]
10468	FLOAT	RD	A	Maximum, Harmonic I L4	[4]
10470	FLOAT	RD	A	Maximum, Harmonic I L4	[5]
10472	FLOAT	RD	A	Maximum, Harmonic I L4	[6]
10474	FLOAT	RD	A	Maximum, Harmonic I L4	[7]
10476	FLOAT	RD	A	Maximum, Harmonic I L4	[8]
10478	FLOAT	RD	A	Maximum, Harmonic I L4	[9]
10480	FLOAT	RD	A	Maximum, Harmonic I L4	[10]
10482	FLOAT	RD	A	Maximum, Harmonic I L4	[11]
10484	FLOAT	RD	A	Maximum, Harmonic I L4	[12]
10486	FLOAT	RD	A	Maximum, Harmonic I L4	[13]
10488	FLOAT	RD	A	Maximum, Harmonic I L4	[14]
10490	FLOAT	RD	A	Maximum, Harmonic I L4	[15]
10492	FLOAT	RD	A	Maximum, Harmonic I L4	[16]
10494	FLOAT	RD	A	Maximum, Harmonic I L4	[17]
10496	FLOAT	RD	A	Maximum, Harmonic I L4	[18]
10498	FLOAT	RD	A	Maximum, Harmonic I L4	[19]
10500	FLOAT	RD	A	Maximum, Harmonic I L4	[20]
10502	FLOAT	RD	A	Maximum, Harmonic I L4	[21]
10504	FLOAT	RD	A	Maximum, Harmonic I L4	[22]
10506	FLOAT	RD	A	Maximum, Harmonic I L4	[23]
10508	FLOAT	RD	A	Maximum, Harmonic I L4	[24]
10510	FLOAT	RD	A	Maximum, Harmonic I L4	[25]
10512	FLOAT	RD	A	Maximum, Harmonic I L4	[26]
10514	FLOAT	RD	A	Maximum, Harmonic I L4	[27]
10516	FLOAT	RD	A	Maximum, Harmonic I L4	[28]
10518	FLOAT	RD	A	Maximum, Harmonic I L4	[29]
10520	FLOAT	RD	A	Maximum, Harmonic I L4	[30]
10522	FLOAT	RD	A	Maximum, Harmonic I L4	[31]
10524	FLOAT	RD	A	Maximum, Harmonic I L4	[32]
10526	FLOAT	RD	A	Maximum, Harmonic I L4	[33]
10528	FLOAT	RD	A	Maximum, Harmonic I L4	[34]
10530	FLOAT	RD	A	Maximum, Harmonic I L4	[35]
10532	FLOAT	RD	A	Maximum, Harmonic I L4	[36]
10534	FLOAT	RD	A	Maximum, Harmonic I L4	[37]
10536	FLOAT	RD	A	Maximum, Harmonic I L4	[38]
10538	FLOAT	RD	A	Maximum, Harmonic I L4	[39]

Maximum values, typ short, fourier analysis

The measured values in short format do not contain current and voltage transformer ratios.

Address	Format	RD/WR	Unit	Note	Index	Resolution
10721	SHORT	RD	mA	Maximum, Harmonic I L4	[0]	1
10722	SHORT	RD	mA	Maximum, Harmonic I L4	[1]	1
10723	SHORT	RD	mA	Maximum, Harmonic I L4	[2]	1
10724	SHORT	RD	mA	Maximum, Harmonic I L4	[3]	1
10725	SHORT	RD	mA	Maximum, Harmonic I L4	[4]	1
10726	SHORT	RD	mA	Maximum, Harmonic I L4	[5]	1
10727	SHORT	RD	mA	Maximum, Harmonic I L4	[6]	1
10728	SHORT	RD	mA	Maximum, Harmonic I L4	[7]	1
10729	SHORT	RD	mA	Maximum, Harmonic I L4	[8]	1
10730	SHORT	RD	mA	Maximum, Harmonic I L4	[9]	1
10731	SHORT	RD	mA	Maximum, Harmonic I L4	[10]	1
10732	SHORT	RD	mA	Maximum, Harmonic I L4	[11]	1
10733	SHORT	RD	mA	Maximum, Harmonic I L4	[12]	1
10734	SHORT	RD	mA	Maximum, Harmonic I L4	[13]	1
10735	SHORT	RD	mA	Maximum, Harmonic I L4	[14]	1
10736	SHORT	RD	mA	Maximum, Harmonic I L4	[15]	1
10737	SHORT	RD	mA	Maximum, Harmonic I L4	[16]	1
10738	SHORT	RD	mA	Maximum, Harmonic I L4	[17]	1
10739	SHORT	RD	mA	Maximum, Harmonic I L4	[18]	1
10740	SHORT	RD	mA	Maximum, Harmonic I L4	[19]	1
10741	SHORT	RD	mA	Maximum, Harmonic I L4	[20]	1
10742	SHORT	RD	mA	Maximum, Harmonic I L4	[21]	1
10743	SHORT	RD	mA	Maximum, Harmonic I L4	[22]	1
10744	SHORT	RD	mA	Maximum, Harmonic I L4	[23]	1
10745	SHORT	RD	mA	Maximum, Harmonic I L4	[24]	1
10746	SHORT	RD	mA	Maximum, Harmonic I L4	[25]	1
10747	SHORT	RD	mA	Maximum, Harmonic I L4	[26]	1
10748	SHORT	RD	mA	Maximum, Harmonic I L4	[27]	1
10749	SHORT	RD	mA	Maximum, Harmonic I L4	[28]	1
10750	SHORT	RD	mA	Maximum, Harmonic I L4	[29]	1
10751	SHORT	RD	mA	Maximum, Harmonic I L4	[30]	1
10752	SHORT	RD	mA	Maximum, Harmonic I L4	[31]	1
10753	SHORT	RD	mA	Maximum, Harmonic I L4	[32]	1
10754	SHORT	RD	mA	Maximum, Harmonic I L4	[33]	1
10755	SHORT	RD	mA	Maximum, Harmonic I L4	[34]	1
10756	SHORT	RD	mA	Maximum, Harmonic I L4	[35]	1
10757	SHORT	RD	mA	Maximum, Harmonic I L4	[36]	1
10758	SHORT	RD	mA	Maximum, Harmonic I L4	[37]	1
10759	SHORT	RD	mA	Maximum, Harmonic I L4	[38]	1
10760	SHORT	RD	mA	Maximum, Harmonic I L4	[39]	1