

# GOLD FLUSH-FIT

## IP40 FLUSH-FIT DISTRIBUTION BOXES

Description: IP40 FLUSH-FIT BOX 3x12 (36) MOD. PE+N

Reference:

**GPE36PT3F/RR**

### Characteristics:

<b>Product type:</b>	IP40 Flush-fit distribution box 36 modules, transparent door and screwed neutral and earth bar
<b>Exterior dimensions (Height x Width x Depth):</b>	574x316x97 mm
<b>Dimensions of the flush-fit gap (HxWxD):</b>	546x288x74 mm
<b>Number of modules:</b>	3x12 (36) DIN rail
<b>Installation:</b>	Flush-fitted brick walls
<b>Color:</b>	RAL 9003
<b>Window:</b>	Transparent
<b>Weight (kg):</b>	2,69
<b>Cable entry:</b>	Bottom: 1xM50/M40 4xM25/M20 5xM25/M16 - Rear: 2xM40/M32 4xM25 - Left: 4xØ32 - Right: 4xØ32
<b>Components:</b>	Cable section: 12x(2,5-6 mm <sup>2</sup> )+12x(4-10 mm <sup>2</sup> )+1x(10-25 mm <sup>2</sup> )+1x(16-35 mm <sup>2</sup> )
<b>Materials:</b>	Halogen-free plastic materials. Base: PS. Frame: ABS
<b>Lid-window-door material:</b>	Tinted PC

### Technical data:

<b>Degree of protection:</b>	IP40
<b>Resistance to impact:</b>	IK08
<b>Glow wire resistance:</b>	650 °C
<b>Ball pressure test:</b>	70 °C
<b>Ambient temperature range:</b>	-25 °C / +40 °C
<b>Maximum operating voltage:</b>	1000 V AC / 1500 V DC
<b>Rated current:</b>	125A
<b>Double insulation:</b>	Class II

### Certificates and standards:

<b>Directive:</b>	2014/35/EU
<b>Standards:</b>	IEC 62208, IEC 61439-1
<b>Certificates:</b>	



### Codes:

<b>EAN:</b>	8431044179773
<b>Customs tariff number:</b>	85.38.10.00
<b>ETIM 8.0:</b>	EC000214

# GOLD FLUSH-FIT

## IP40 FLUSH-FIT DISTRIBUTION BOXES

Description: IP40 FLUSH-FIT BOX 3x12 (36) MOD. PE+N

Reference: GPE36PT3F/RR

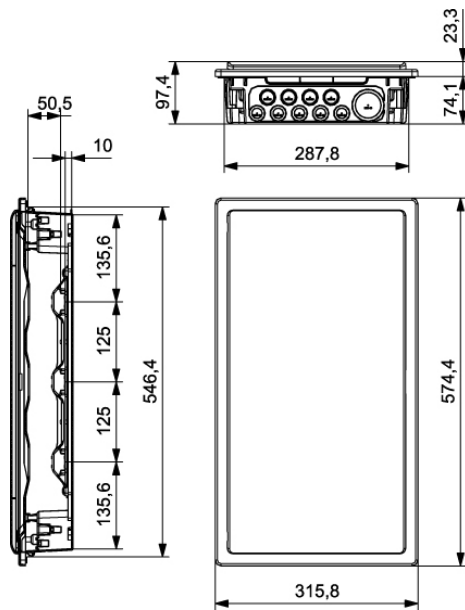

### Detailed drawing:

 <http://www.ide.es/downloads/planos/pdf/GPE36PT3FRR.pdf>

 <http://www.ide.es/downloads/planos/dxf/GPE36PT3FRR.dxf>

 <http://www.ide.es/downloads/planos/stp/GPE36PT3FRR.stp>

### Exterior dimensions (Height x Width x Depth):

574x316x97 mm

### Dimensions of the flush-fit gap (Height x Width x Depth):

546x288x74 mm

### Sustainability:

RoHS - REACH

### Supply:

Supplied in individual cardboard packaging. When several items are sent together, they are bundled together with transparent film.

Packaging units: 4

### Product end of life:

It does not require specific recycling operations.

### Recommended applications:

Tertiary and residential sectors. For use indoors, designed for flush-fit installation. Flats, houses, offices, hotels, etc.