

Susol Molded Case Circuit Breaker TS250N

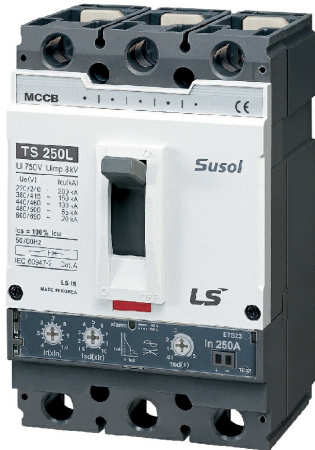

General

Product code	0105028400
Product description	TS250N ETS23 250A 3P EXP
Trip Unit	ETS(Electronic, LSI)
[In] rated current	250 A at 40 °C
Poles description	3P
Protected poles description	3T
Neutral position	-
Network type	AC (50/60 Hz), DC
Upside connection	Front (screw)
Downside connection	Front (screw)

Characteristics

[Ue] rated operational voltage (AC 50/60 Hz)	690 V AC
[Ue] rated operational voltage (DC)	500 V DC
[Uimp] rated impulse withstand voltage	8 kV
[Ui] rated insulation voltage	1000 V
Mechanical durability	25000 cycles

Electrical durability (AC)	10000 cycles 415 V In
Electrical durability (DC)	-
Utilisation category	Category A
Suitability for isolation	Yes
Reference standard	IEC 60947-2
[Icu] rated Ultimate short-circuit breaking capacity	100 kA at 220/240 V AC 50/60 Hz, IEC 60947-2
	50 kA at 380/415 V AC 50/60 Hz, IEC 60947-2
	50 kA at 440/460 V AC 50/60 Hz, IEC 60947-2
	42 kA at 480/500 V AC 50/60 Hz, IEC 60947-2
	22 kA at 525 V AC 50/60 Hz, IEC 60947-2
	10 kA at 660/690 V AC 50/60 Hz, IEC 60947-2
	50 kA at 250 V DC, Reference
[Ics] rated service breaking capacity	50 kA at 500 V DC (2poles in series), Reference
	100 kA at 220/240 V AC 50/60 Hz, IEC 60947-2
	50 kA at 380/415 V AC 50/60 Hz, IEC 60947-2
	50 kA at 440/460 V AC 50/60 Hz, IEC 60947-2
	42 kA at 480/500 V AC 50/60 Hz, IEC 60947-2
	22 kA at 525 V AC 50/60 Hz, IEC 60947-2
	5 kA at 660/690 V AC 50/60 Hz, IEC 60947-2
50 kA at 250 V DC, Reference	
[Icm] rated short-circuit marking capacity	50 kA at 500 V DC (2poles in series), Reference
	220 kA at 220/240 V AC 50/60 Hz, IEC 60947-2
	105 kA at 380/415 V AC 50/60 Hz, IEC 60947-2
	105 kA at 440/460 V AC 50/60 Hz, IEC 60947-2
	88 kA at 480/500 V AC 50/60 Hz, IEC 60947-2
	46 kA at 525 V AC 50/60 Hz, IEC 60947-2
[Icw] rated short-time	17 kA at 660/690 V AC 50/60 Hz, IEC 60947-2
	-

withstand current	-
	-
Trip unit characteristics	Electronic
	L : for overload protection (long time)
	S : for short time short-circuit protection
	I : for instantaneous short-circuit protection
	-
	-
	-
	-
[Ir] Long-time pick-up adjustment range	Adjustable, 13 settings
	0.4, 0.45, 0.5, 0.55, 0.6, 0.65, 0.7, 0.75, 0.8, 0.85, 0.9, 0.95, 1.0 x In
[Iu] Long-time pick-up adjustment range	-
	-
[tr] Long-time delay adjustment range	Fixed
	at 6 x Ir, tolerance $\pm 20\%$
[Isd] Short-time pick-up adjustment range	Adjustable, 9 settings
	1.5, 2, 3, 4, 5, 6, 7, 8, 10 x Ir, tolerance $\pm 15\%$
[tsd] Short-time delay adjustment range	Adjustable, 4 settings
	-
	50ms (Tripping time : 30ms < t \leq 70ms)
	100ms (Tripping time : 70ms < t \leq 140ms)
	200ms (Tripping time : 140ms < t \leq 240ms)
	300ms (Tripping time : 240ms < t \leq 350ms)
[Ii] Instantaneous pick-up adjustment range	Fixed
	11 x In

[lg] Ground-fault protection pick-up adjustment range	-
	-
	-
[tg] Ground-fault protection time delay adjustment range	-
	-
	-
	-
Earth leakage pick-up adjustment range	-
	-
Earth leakage alarm time delay adjustment range	-
	-
Earth leakage trip time delay adjustment range	-
	-
[lp] Pre-trip alarm pick-up adjustment range	-
	-
[tp] Pre-trip alarm time delay adjustment range	-
	-
Alarm LED	Ir (90% ~ 105%) : Trun on
	Ir (105% ~) : Blink

Environment

Pollution degree	3, IEC 60664-1
Degree of protection	IP20, IEC 60529
Ambient air temperature for operation	-20...70 °C
Ambient air temperature for storage	-40...70 °C
Mounting mode	Fixed

Mounting support	Backplate
Approvals ¹⁾ (General)	CE (Europe)
	-
	-
	CCC (China)
	EAC (Russia)
	IC (Korea)
Approvals (shipping)	LR (U.K)
	BV (France)
	ABS (U.S.A)
	GL (Germany)
	DNV (Norway)
	RINA (Italy)
	KR (Korea)

1) LS ELECTRIC's standard products are designed for CE.

To check the product with regional certificates, please contact LSE sales representatives.

Dimensions

Product	Width	105 mm
	Height	160 mm
	Depth	86 mm
	Weight	2 kg
Packing	Width	335 mm
	Height	565 mm
	Depth	132 mm
	Weight	20 kg
	Quantity (in a box)	10 pcs.

TS100/160/250

[mm]

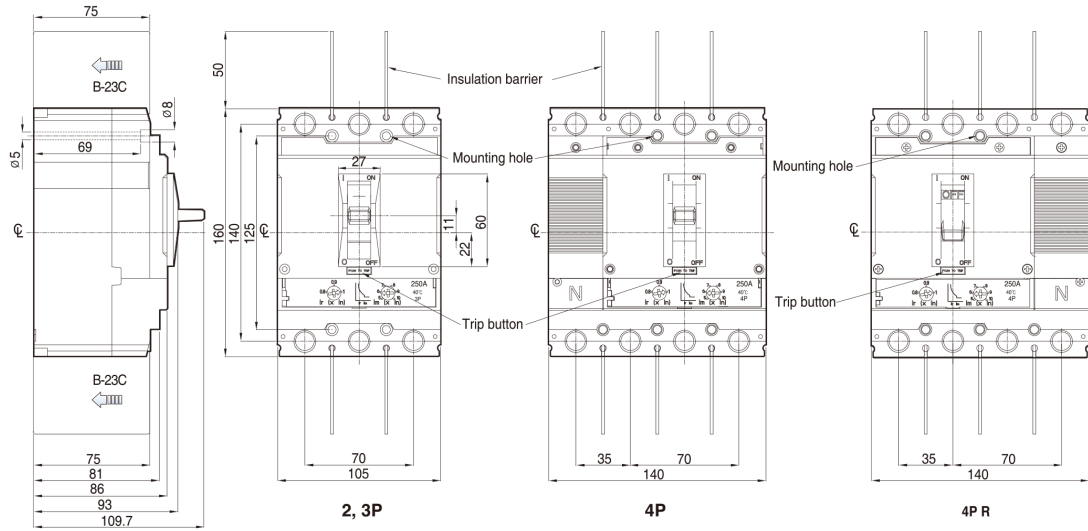

Terminal section



Conductor

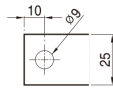

Panel drilling

Front panel cutting

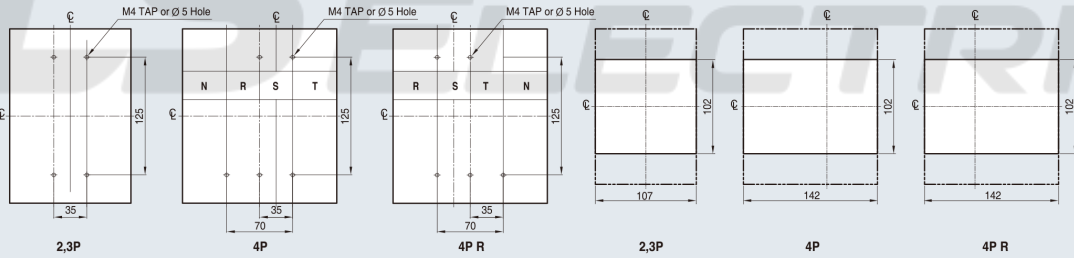

LS ***ELECTRIC***