

Chapter 3 Environment and Installation

3.1 Environment

The environment will directly affect the proper operation and the life span of the inverter. To ensure that the inverter will give maximum service life, please comply with the following environmental conditions:

Protection	
Protection Class	IP20/NEMA 1 or IP00
Operating Temperature	Ambient Temperature: (-10°C - +40°C (14 -104 °F) Without Cover: -10°C - +50°C (14-122 °F); but it is required to derate 2% of current at each additional 1°C. The maximum operating temperature is 60°C . If several inverters are placed in the same control panel, provide a heat removal means to maintain ambient temperatures below 40°C
Storage Temperature	-20°C - +70°C (-4 -158 °F)
Humidity	95% non-condensing Relative humidity 5% to 95%, free of moisture. (Follow IEC60068-2-78 standard)
Altitude	Altitude: Below 1000 m (3281 ft.) It is required to derate 1% of current at each additional 100 m. The maximum altitude is 3000 m .
Installation Site	Avoid exposure to rain or moisture.
	Avoid direct sunlight.
	Avoid oil mist and salinity.
	Avoid corrosive liquid and gas.
	Avoid dust, lint fibers, and small metal filings.
	Keep away from radioactive and flammable materials.
	Avoid electromagnetic interference (soldering machines, power machines).
Avoid vibration (stamping, punching machines etc.). Add a vibration-proof pad if the situation cannot be avoided.	
Shock	Maximum acceleration: 1.0G (9.8m/s ²), from 49.84 to 150 Hz Displacement amplitude : 0.3mm (peak value), from 10 to 49.84 Hz (Follow IEC60068-2-6 standard)

3.2 Installation

When installing the inverter, ensure that inverter is installed in upright position (vertical direction) and there is adequate space around the unit to allow normal heat dissipation as per the following Fig. 3.2.1

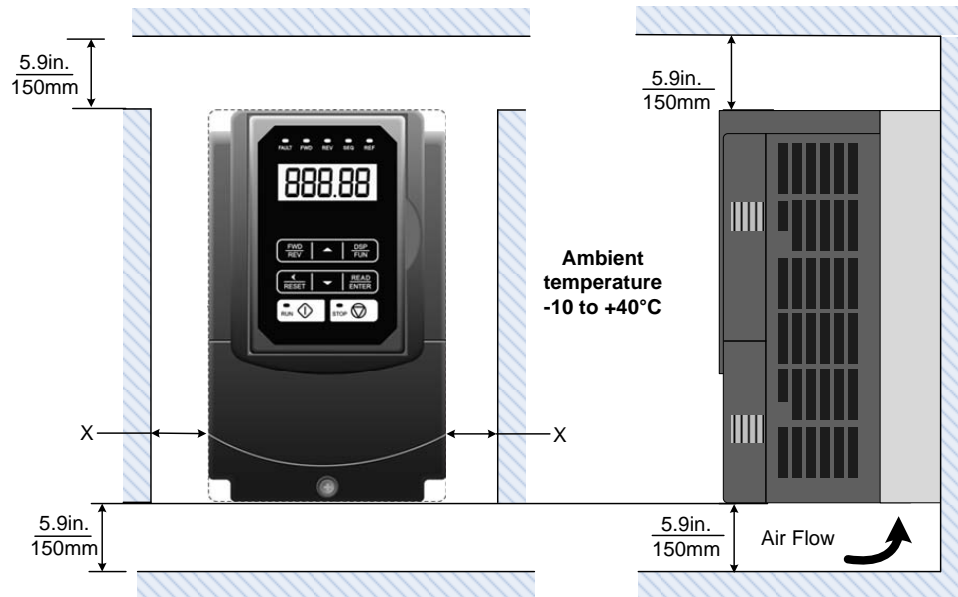

Fig 3.2.1: A510S Installation space

X = 1.18" (30mm) for inverter ratings up to 25HP

X = 1.96" (50mm) for inverter ratings 30HP or higher

Important Note: The inverter heatsink temperature can reach up to 194°F / 90°C during operation; make sure to use insulation material rated for this temperature.

3.3 External View

(a) 200V 1 ~ 7.5 HP / 400V 1 ~ 7.5 HP / 575V 1~ 3 HP

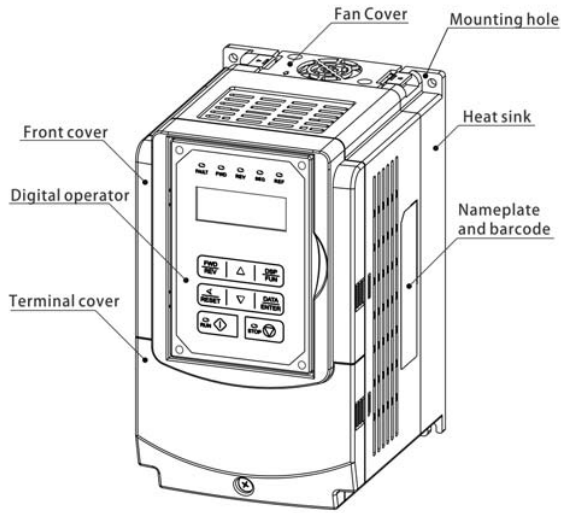

(Wall-mounted type, IEC IP20)

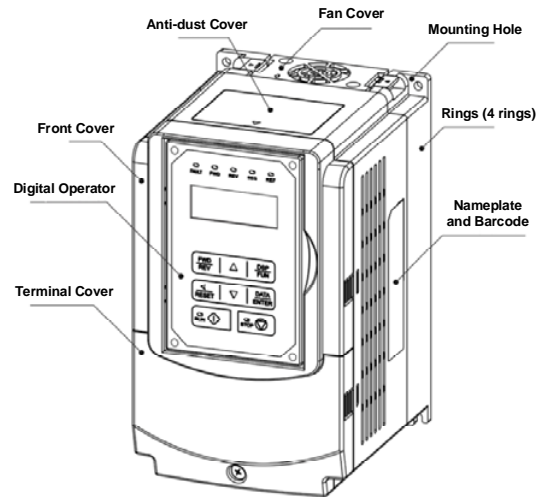

(Wall-mounted type, IEC IP20, NEMA1)

(b) 200V 10 ~ 25 HP / 400V 10 ~ 30 HP / 575V 5~10HP / 690V 15~40HP

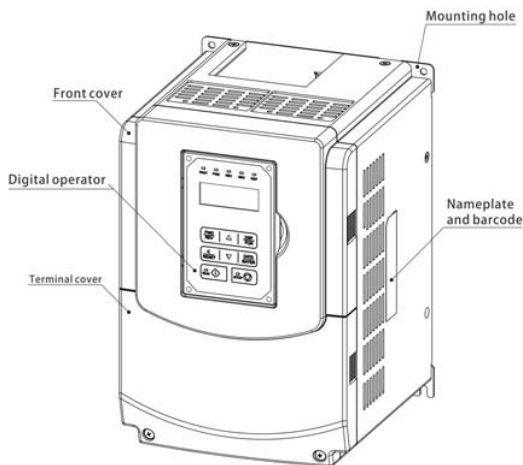

(Wall-mounted type, IEC IP20)

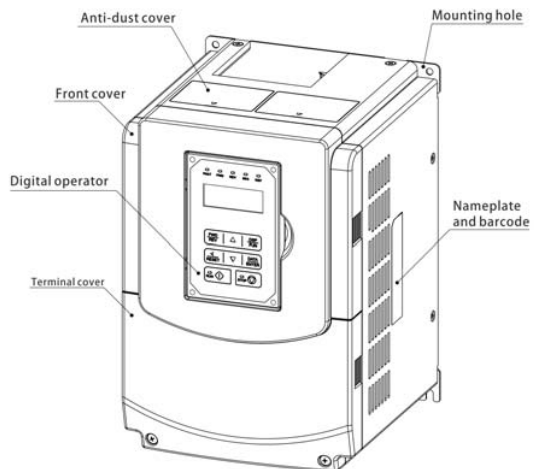

(Wall-mounted type, IEC IP20, NEMA1)

(c) 200V 30 ~ 40 HP / 400V 40 ~ 75 HP / 690V 50~75HP

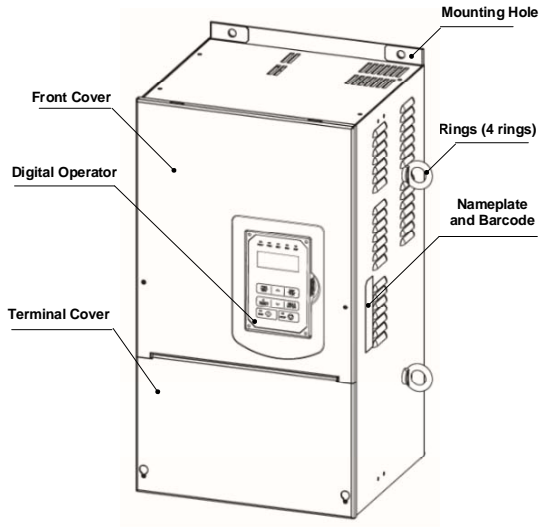

(Wall-mounted type, IEC IP20, NEMA1)

(d) 200V 50 ~ 100 HP / 400V 100 ~ 215 HP / 690V 100~270HP

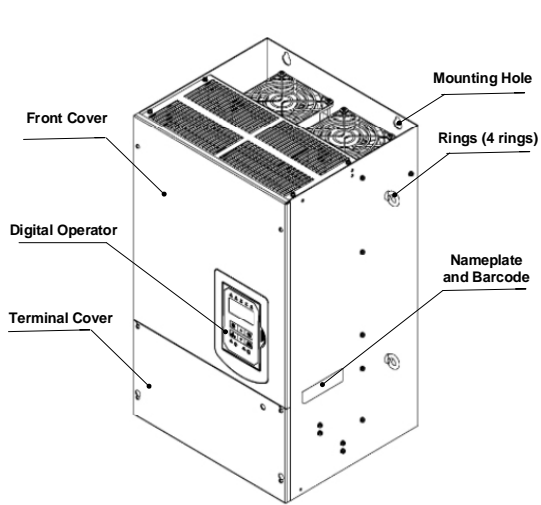

(Wall-mounted type, IEC IP00)

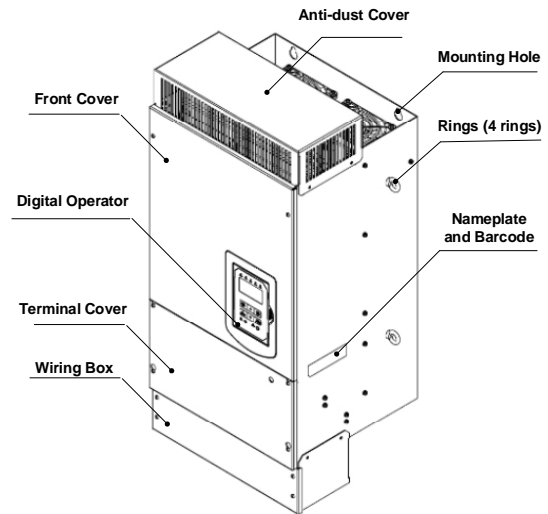

(Wall-mounted type, IEC IP20, NEMA1)

(e) 200V 125 ~ 150 HP / 400V 270 ~ 425 HP

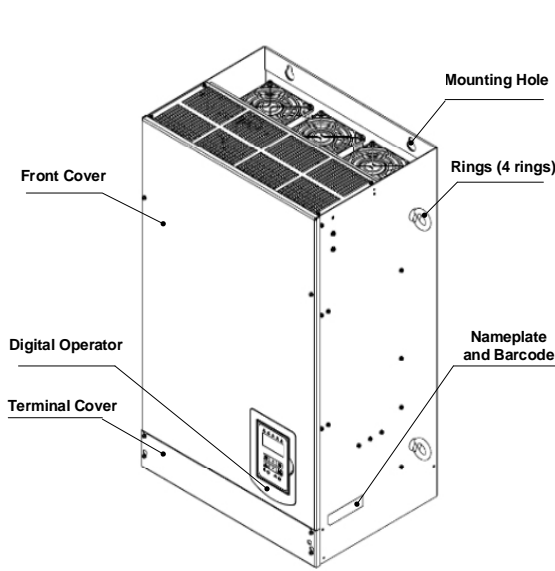

(Wall-mounted type, IEC IP00)

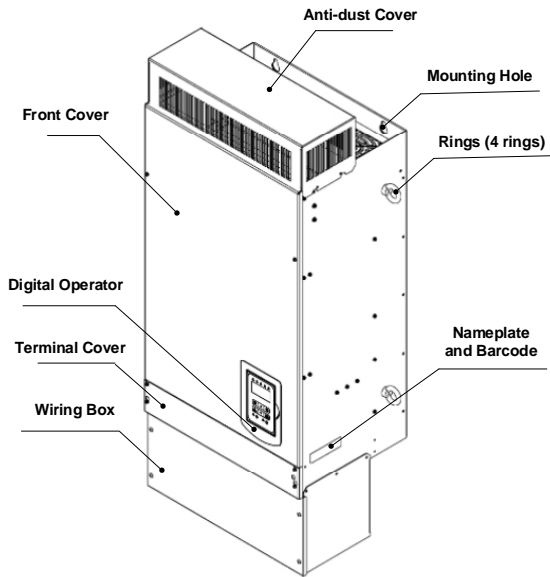

(Wall-mounted type, IEC IP20, NEMA1)

3.4 Warning Labels

Important: Warning information located on the front cover must be read upon installation of the inverter.



(a) 200V: 1-7.5HP / 400V: 1-7.5HP /575V 1~ 3 HP



(b) 200V: 10HP / 400V: 10-20HP /575V 5~10HP

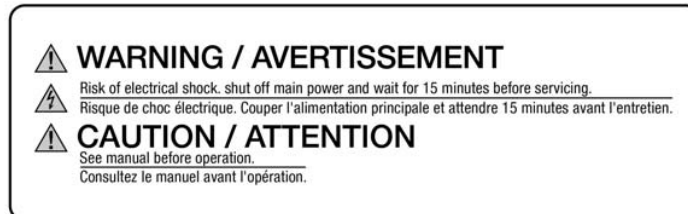

(c) 200V: 15-150HP / 400V: 20(F)-425HP/690V 15~270HP

3.5 Removing the Front Cover and Keypad

 **Caution**

- Before making any wiring connections to the inverter the front cover needs to be removed.
- It is not required to remove the digital operator before making any wiring connections.
- Models 200V, 1 – 25 HP and 400V, 1 – 30 HP and 575V/690V 1 – 40 HP have a plastic cover. Loosen the screws and remove the cover to gain access to the terminals and make wiring connections. Place the plastic cover back and fasten screws when wiring connections have been made.
- Models 200V, 30 - 150HP and 400V, 40 - 425HP and 690V 50 - 270HP have a metal cover. Loosen the screws and remove the cover to gain access to the terminals and make wiring connections. Place the metal cover back and fasten screws when wiring connections have been made.

3.5.1 Standard Type

(a) 200V: 1 ~ 7.5 HP / 400V: 1 ~ 7.5 HP / 575V: 1~3HP

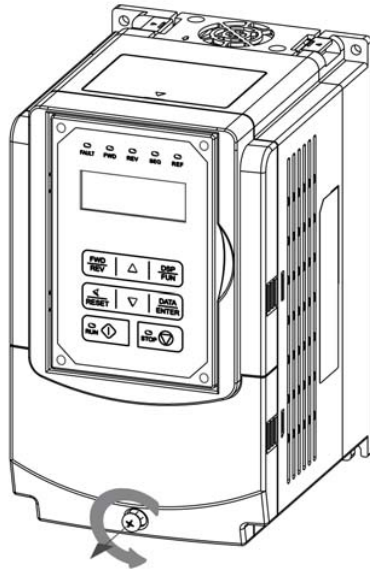

Step 1: Unscrew

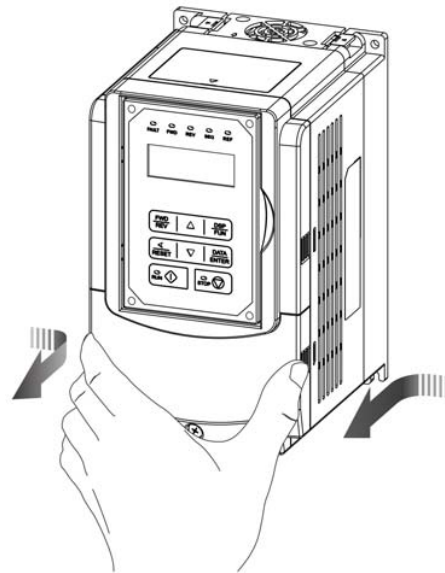

Step 2: Remove cover

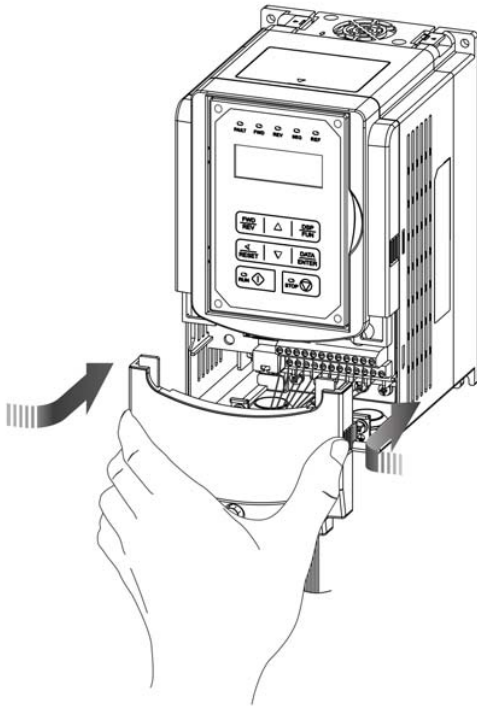

Step 3: Make wire connections and place cover back

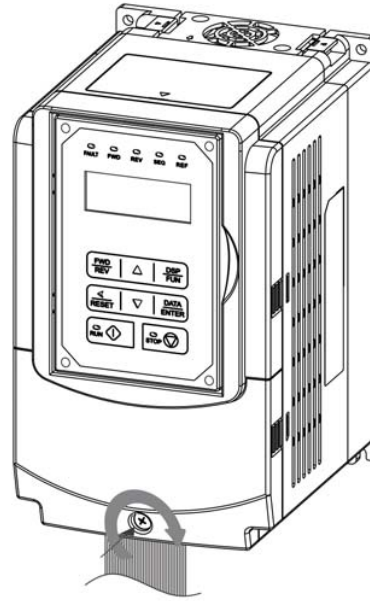

Step 4: Fasten screw

(b) 200V: 10 ~ 25 HP / 400V: 10 ~ 30 HP / 575V: 5~10HP/690V 15~40HP

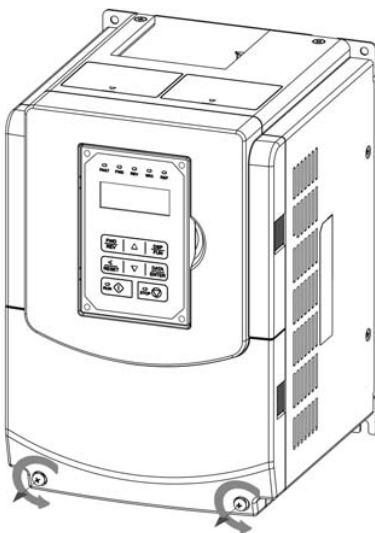

Step 1: Unscrew cover

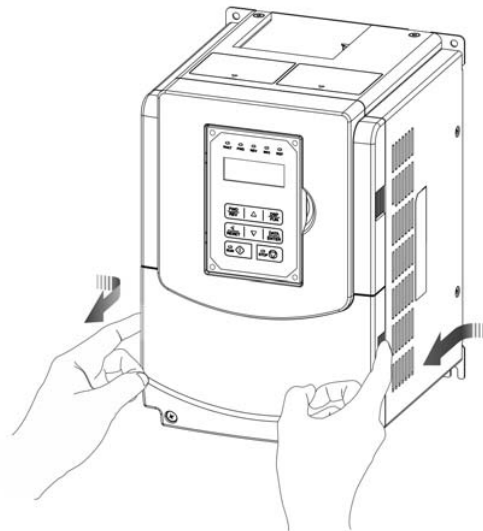

Step 2: Remove cover

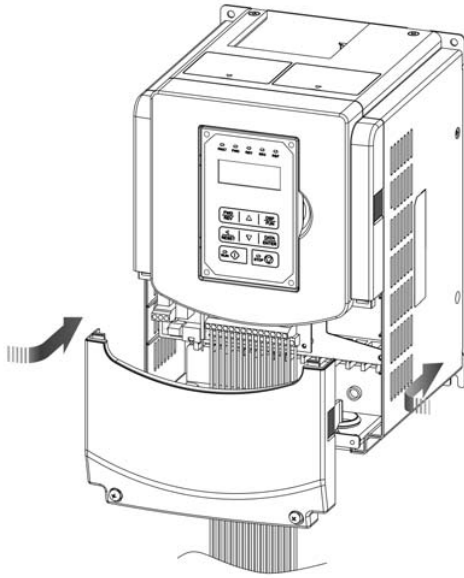

Step 3: Make wire connections and place cover back

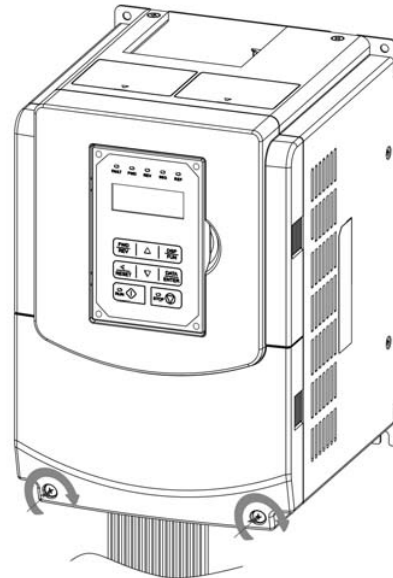

Step 4: Fasten screw

(c) 200V: 30 ~ 40 HP / 400V: 40 ~ 75 HP / 690V: 50~75HP (Chassis Type)

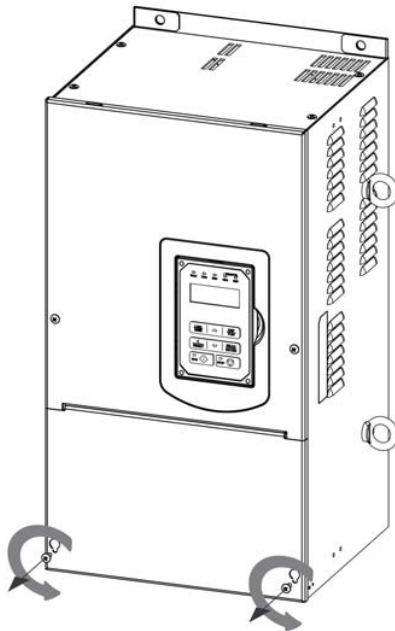

Step 1: Unscrew cover

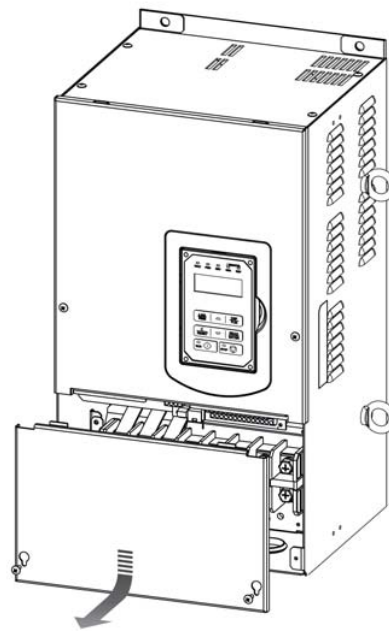

Step 2: Remove cover

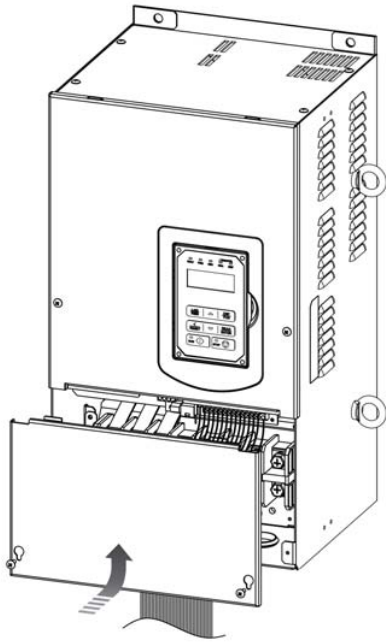

Step 3: Make wire connections and place cover back

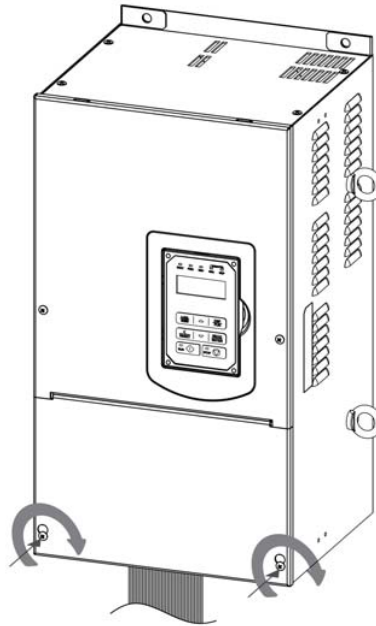

Step 4: Fasten screw

(d) 200V: 50 ~ 100 HP / 400V: 100 ~ 215 HP / 690V: 100~270HP (Chassis Type)

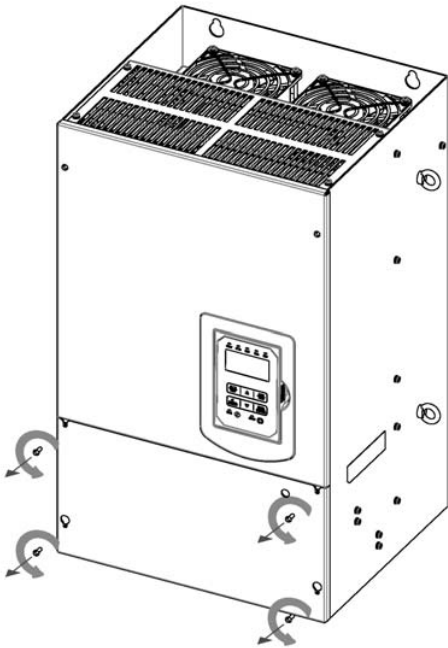

Step 1: Unscrew cover

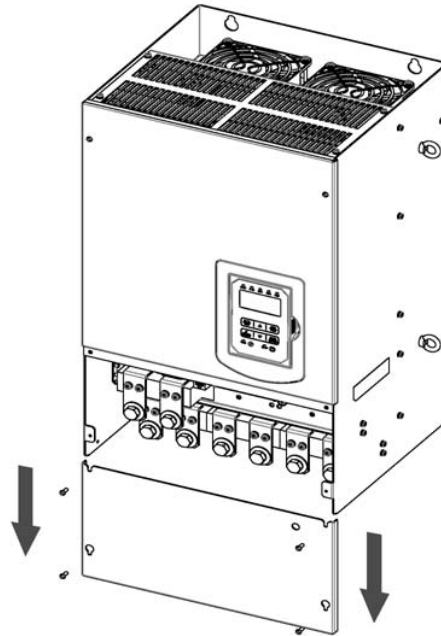

Step 2: Remove cover

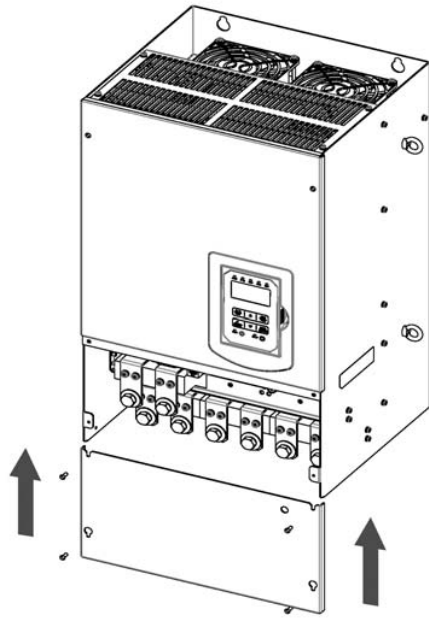

Step 3: Make wire connections and place cover back

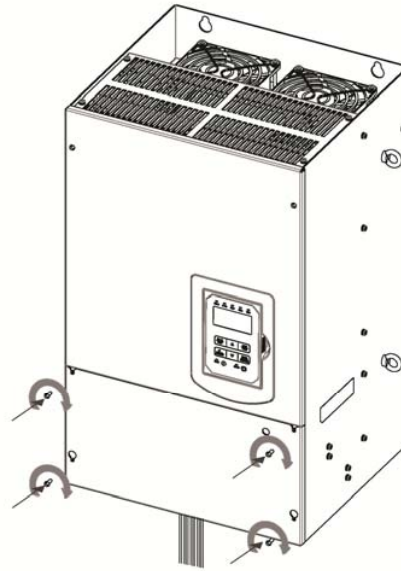

Step 4: Fasten screw

(e) 200V: 125 ~ 150 HP / 400V: 270 ~ 425 HP (Chassis Type)

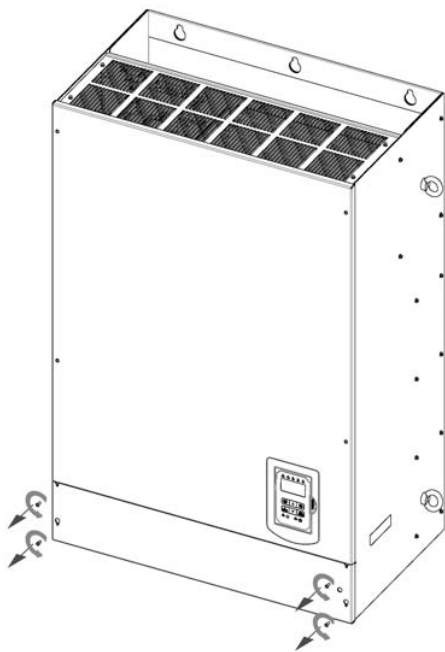

Step 1: Unscrew cover

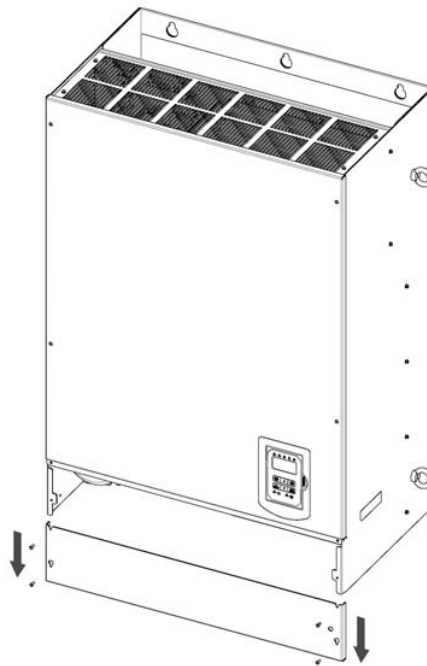

Step 2: Remove cover

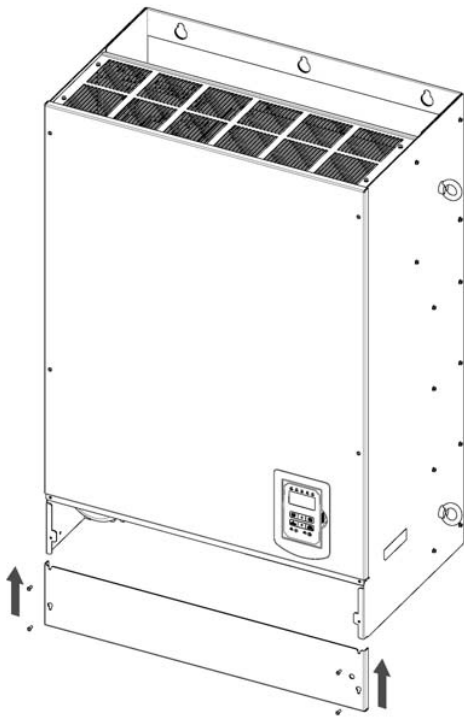

Step 3: Make wire connections and place cover back

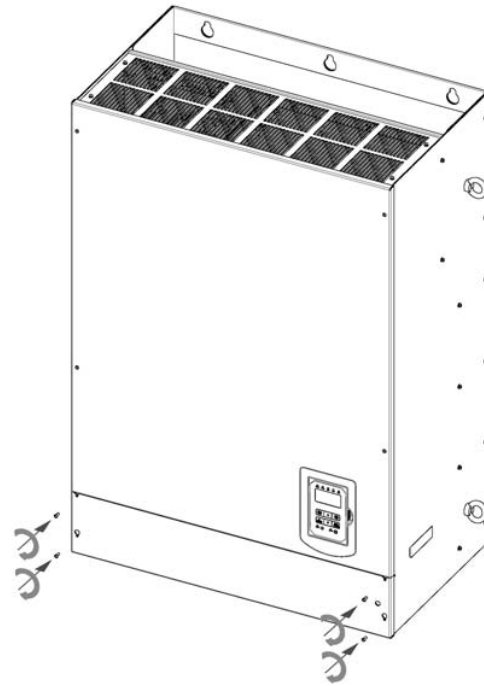

Step 4: Fasten screw

3.5.2 Built-in filter type (400V: 1 ~ 60 HP)



Step 1: Unscrew cover

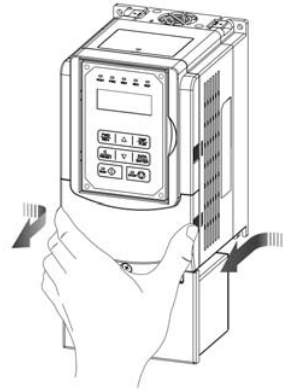

Step 2: Remove cover

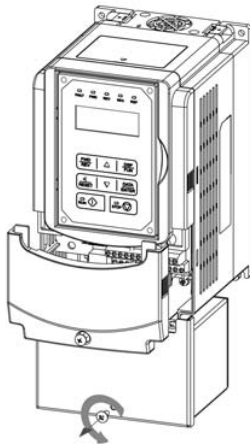

Step 3: Unscrew filter section

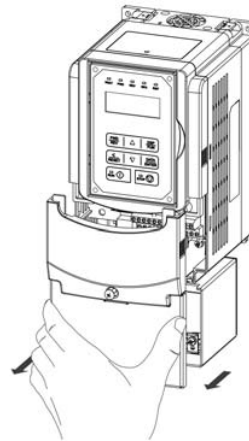

Step 4: Remove filter cover

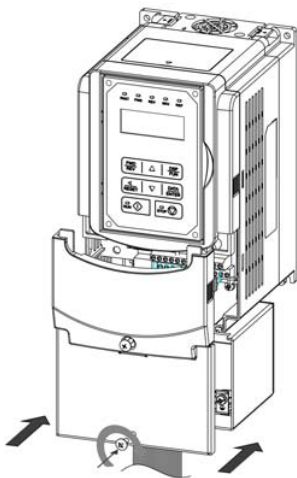

Step 5: Make connections and place filter cover back

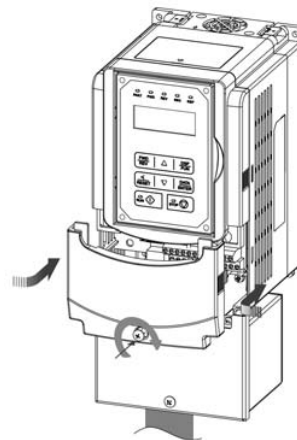

Step 6: Fasten screw

3.6 Wire Gauges and Tightening Torque

To comply with UL standards, use UL approved copper wires (rated 75° C) and round crimp terminals (UL Listed products) as shown in table below when connecting to the main circuit terminals. TECO recommends using crimp terminals manufactured by NICHIFU Terminal Industry Co., Ltd and the terminal crimping tool recommended by the manufacturer for crimping terminals and the insulating sleeve.

Wire size mm ² (AWG)	Terminal screw size	Model of the round crimp terminal	Fastening torque kgf.cm (in.lbs)	Model of insulating sleeve	Model of crimp tool
0.75 (18)	M3.5	R1.25-3.5	8.2 to 10 (7.1 to 8.7)	TIC 1.25	NH 1
	M4	R1.25-4	12.2 to 14 (10.4 to 12.1)	TIC 1.25	NH 1
1.25 (16)	M3.5	R1.25-3.5	8.2 to 10 (7.1 to 8.7)	TIC 1.25	NH 1
	M4	R1.25-4	12.2 to 14 (10.4 to 12.1)	TIC 1.25	NH 1
2 (14)	M3.5	R2-3.5	8.2 to 10 (7.1 to 8.7)	TIC 2	NH 1 / 9
	M4	R2-4	12.2 to 14 (10.4 to 12.1)	TIC 2	NH 1 / 9
	M5	R2-5	22.1 to 24 (17.7 to 20.8)	TIC 2	NH 1 / 9
	M6	R2-6	25.5 to 30.0 (22.1 to 26.0)	TIC 2	NH 1 / 9
3.5 / 5.5 (12/10)	M4	R5.5-4	12.2 to 14 (10.4 to 12.1)	TIC 5.5	NH 1 / 9
	M5	R5.5-5	20.4 to 24 (17.7 to 20.8)	TIC 5.5	NH 1 / 9
	M6	R5.5-6	25.5 to 30.0 (22.1 to 26.0)	TIC 5.5	NH 1 / 9
	M8	R5.5-8	61.2 to 66.0 (53.0 to 57.2)	TIC 5.5	NH 1 / 9
8 (8)	M4	R8-4	12.2 to 14 (10.4 to 12.1)	TIC 8	NOP 60
	M5	R8-5	20.4 to 24 (17.7 to 20.8)	TIC 8	NOP 60
	M6	R8-6	25.5 to 30.0 (22.1 to 26.0)	TIC 8	NOP 60
	M8	R8-8	61.2 to 66.0 (53.0 to 57.2)	TIC 8	NOP 60
14 (6)	M4	R14-4	12.2 to 14 (10.4 to 12.1)	TIC 14	NH 1 / 9
	M5	R14-5	20.4 to 24 (17.7 to 20.8)	TIC 14	NH 1 / 9
	M6	R14-6	25.5 to 30.0 (22.1 to 26.0)	TIC 14	NH 1 / 9
	M8	R14-8	61.2 to 66.0 (53.0 to 57.2)	TIC 14	NH 1 / 9
22 (4)	M6	R22-6	25.5 to 30.0 (22.1 to 26.0)	TIC 22	NOP 60/ 150H
	M8	R22-8	61.2 to 66.0 (53.0 to 57.2)	TIC 22	NOP 60/ 150H
30 / 38 (3 / 2)	M6	R38-6	25.5 to 30.0 (22.1 to 26.0)	TIC 38	NOP 60/ 150H
	M8	R38-8	61.2 to 66.0 (53.0 to 57.2)	TIC 38	NOP 60/ 150H
50 / 60 (1/1/0)	M8	R60-8	61.2 to 66.0 (53.0 to 57.2)	TIC 60	NOP 60/ 150H
	M10	R60-10	102 to 120 (88.5 to 104)	TIC 60	NOP 150H
70 (2/0)	M8	R70-8	61.2 to 66.0 (53.0 to 57.2)	TIC 60	NOP 150H
	M10	R70-10	102 to 120 (88.5 to 104)	TIC 60	NOP 150H
80 (3/0)	M10	R80-10	102 to 120 (88.5 to 104)	TIC 80	NOP 150H
	M16	R80-16	255 to 280 (221 to 243)	TIC 80	NOP 150H
100 (4/0)	M10	R100-10	102 to 120 (88.5 to 104)	TIC 100	NOP 150H
	M12	R100-12	143 to 157 (124 to 136)	TIC 100	NOP 150H
	M16	R80-16	255 to 280 (221 to 243)	TIC 80	NOP 150H

3.7 Wiring Peripheral Power Devices

 **Caution**

- After power is shut off to the inverter the capacitors will slowly discharge. Do NOT touch the inverter circuit or replace any components until the “CHARGE” indicator is off.
- Do NOT wire or connect/disconnect internal connectors of the inverter when the inverter is powered up or after power off but the “CHARGE” indicator is on.
- Do NOT connect inverter output U, V and W to the AC power source. This will result in damage to the inverter.
- The inverter must be properly grounded. Use terminal E to connect earth ground and comply with local standards.
- It is required to disconnect the ground wire in the control board if the inverter is not grounded.
- Do NOT perform a dielectric voltage withstand test (Megger) on the inverter this will result in inverter damage to the semiconductor components.
- Do NOT touch any of the components on the inverter control board to prevent damage to the inverter by static electricity.

200V: 1HP~2HP/ 400V: 1HP~3HP

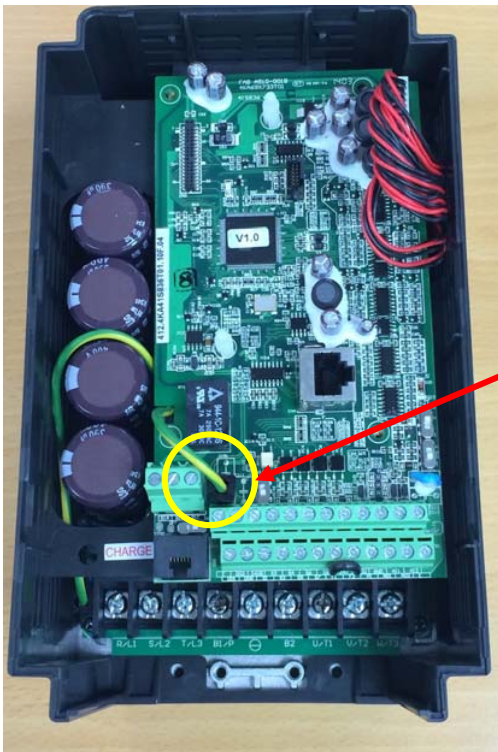

- **Disconnect the ground wire of J1. on the control board (C/B).**

200V: 3HP~8HP/ 400V: 5HP~8HP/575V: 1~3HP



- Disconnect the ground wire of J1. on the control board (C/B).

200V: 10HP/ 400V: 10~20HP/575V: 5~10HP

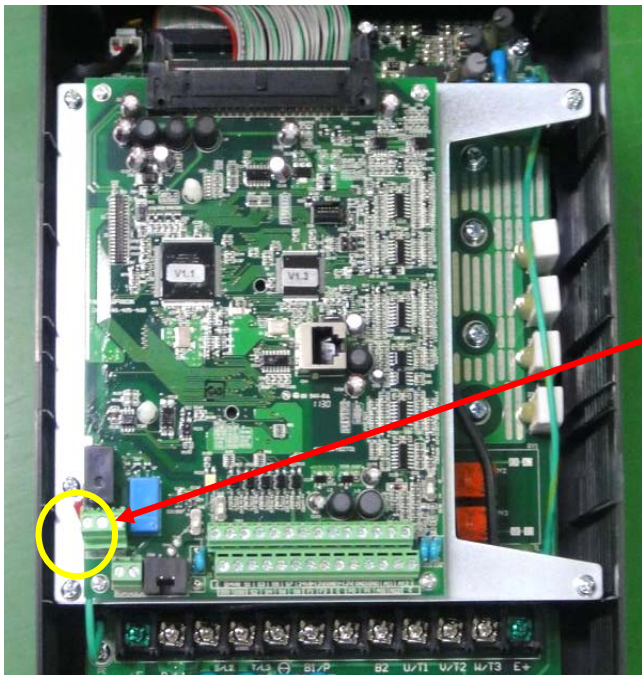

- Disconnect the ground wire of isolated metal plate.

200V: 15- 25HP/ 400V: 25~30HP/690V: 15~40HP

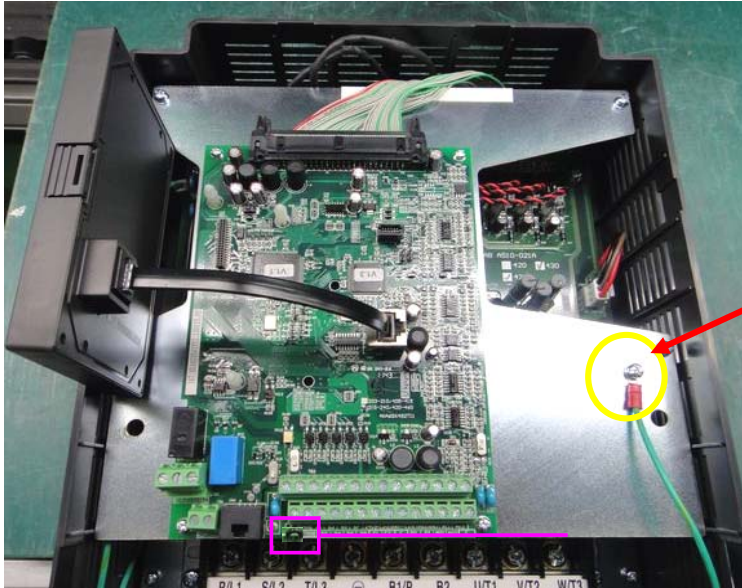

- Disconnect the ground wire of isolated metal plate.

200V: 30-40HP/ 400V: 40-75HP/690V: 50~75HP

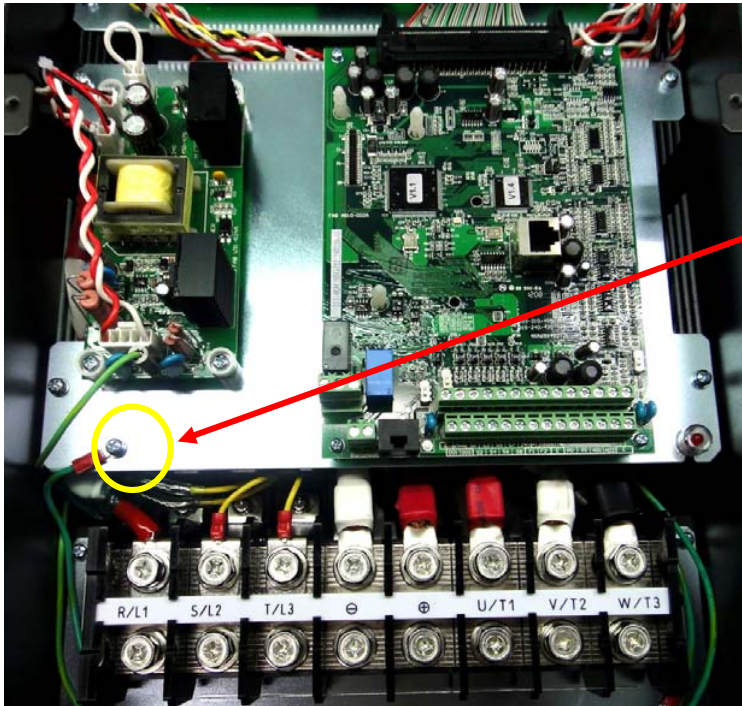

- Disconnect the ground wire of isolated metal plate.

200V: 50HP/ 400V: 100HP and the above/690V: 100HP

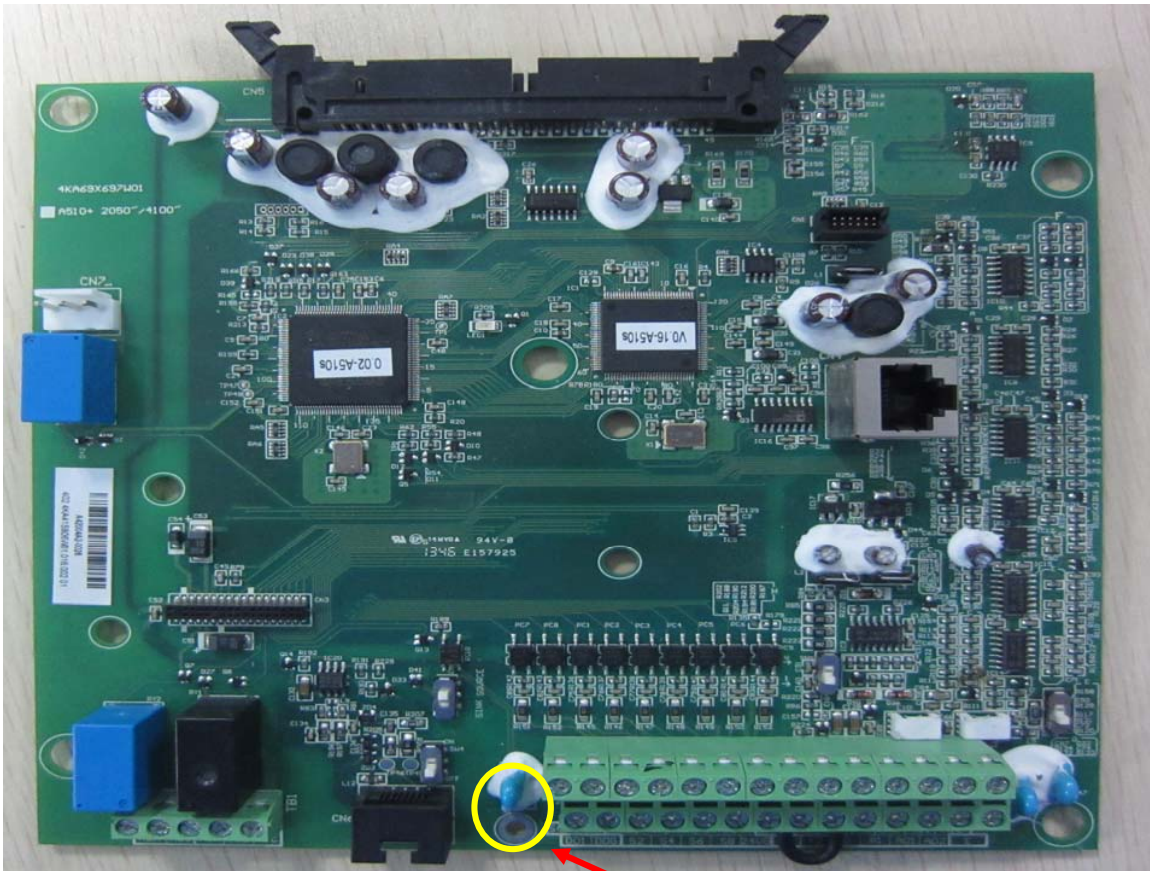

- Disconnect the ground screw below the C/B and ground studs of isolated metal plate.

 **Caution**

- Refer to the recommended wire size table for the appropriate wire to use. The voltage between the power supply and the input terminals of the inverter may not exceed 2%.

Phase-to-phase voltage drop (V) = $\sqrt{3}$ × resistance of wire (Ω/km) × length of line (m) × current × 10⁻³.
(km=3280 x feet) / (m=3.28 x feet)

- Reduce the carrier frequency (parameter 11-01) if the cable from the inverter to the motor is over 25m (82ft). A high-frequency current can be generated by stray capacitance between the cables and result in an overcurrent trip of the inverter, an increase in leakage current, or an inaccurate current readout.
- To protect peripheral equipment, install fast acting fuses on the input side of the inverter. Refer to section 11.4 for additional information.

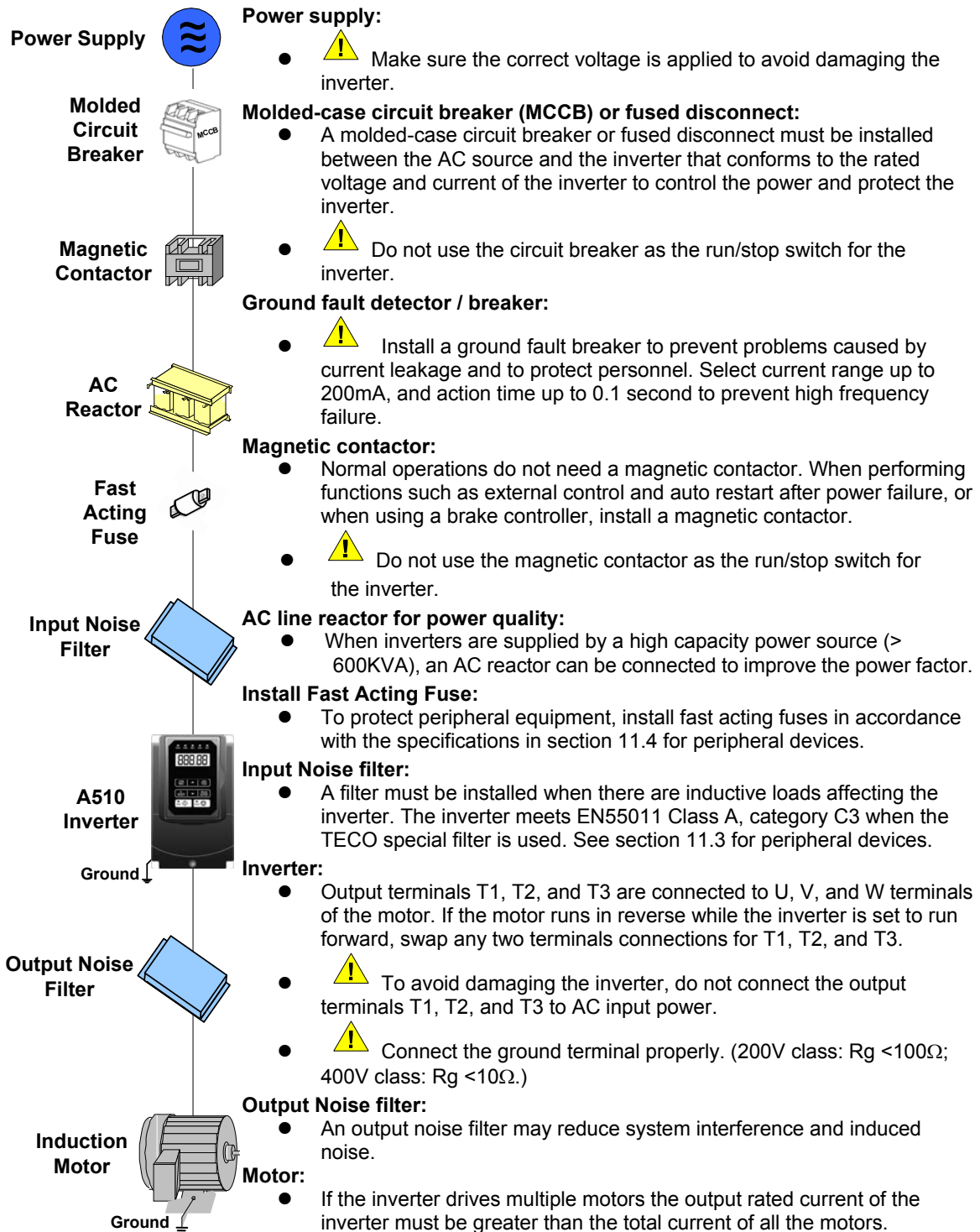

3.8 General Wiring Diagram

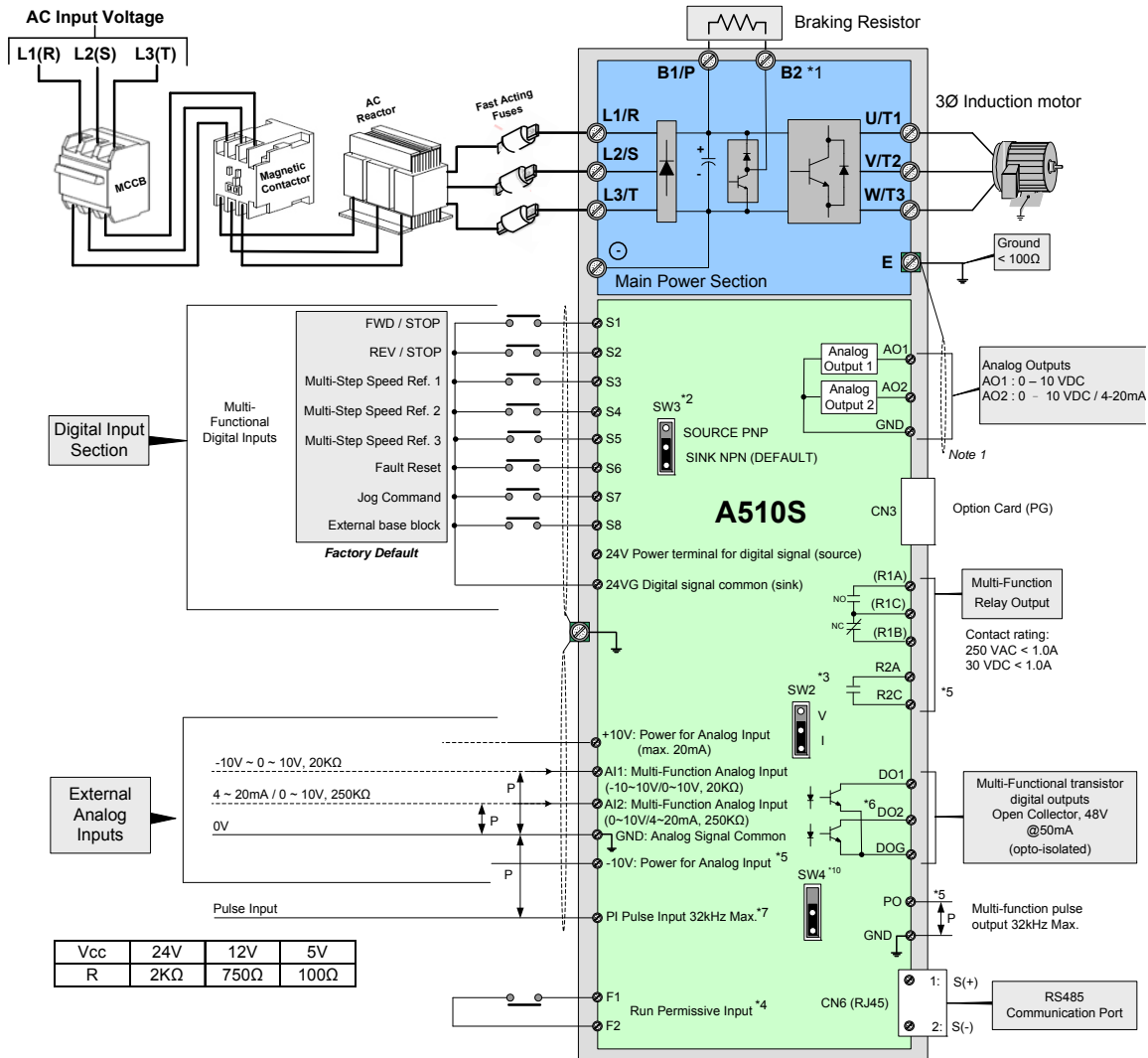

Notes:

- *1: Models 200V 1 ~ 25HP and 400V 1 ~ 40HP or lower ratings have a built-in braking transistor. To use this braking transistor a braking resistor can be connected between B1 and B2.
- *2: Use SW3 to select between Sink (NPN, with 24VG common) or Source (PNP, with +24V common) for multi-function digital input terminals S1~S8.
- *3: Use SW2 to switch between voltage (0~10V/-10~10V) and current (4~20mA) input for Multi-function analog input 2 (AI2).
- *4: Run Permissive input F1 and F2 is a normally closed input. This input should be closed to enable the inverter output. To activate this input remove the jumper wire between F1 and F2.
- *5: Models 200V 3HP and 400V 5HP and higher ratings include terminals -10V, S(+), S(-), R2A-R2C and PO-GND.
- *6: 200V 2HP and 400V 3HP and lower ratings include terminal DO2.
- *7: When using the open collector for pulse input, it doesn't need resistance because of built-in pull-up resistance.
- *8: AO2 default setting is 0~+10V.
- *9 Both 200V class 50HP~150HP and 400V class 100HP~425HP have built-in DC reactors.
- *10 It need turn on the switch for the terminal resistor RS485 in the last inverter when many inverters in parallel connection.

Please refer to Appendix A

3.9 User Terminals (Control Circuit Terminals)

200V: 1 ~ 2 HP, 400V: 1 ~ 3HP

R1A	R1B	R1C	E	DO2	24VG	S2	S4	S6	S8	24V	+10V	GND	AI1	AI2
	RJ45		DO1	DOG	S1	S3	S5	S7	F1	F2	PI	AO1	AO2	E

200V: 3 ~ 150 HP, 400V: 5 ~ 425HP, 575V:1~10HP, 690V:15~270HP

R1A	R1B	R1C	R2A	R2C	S(+)	S(-)	S1	S3	S5	S7	24V	+10V	GND	-10V	GND	GND	AI1	AI2
			RJ45		DO1	DOG	S2	S4	S6	S8	24VG	F1	F2	PO	PI	AO1	AO2	E

Description of User Terminals

Type	Terminal	Terminal Function	Signal Level / Information
Digital input signal	S1	2-wire forward/ stop (default) * 1	Signal Level 24 VDC (photo isolated) Maximum current: 8mA Maximum voltage: 30 Vdc Input impedance: 4.22kΩ
	S2	2-wire reversal/ stop (default) * 1	
	S3	Multi-speed/ position setting command 1 (default) * 1	
	S4	Multi-speed/ position setting command 2 (default) * 1	
	S5	Multi-speed/ position setting command 3 (default) * 1	
	S6	Fault reset (default) * 1	
	S7	JOG frequency command (default) * 1	
	S8	External B.B.(Base Block) stop (coast to stop) (default) * 1	
24V Power supply	24V	Digital signal SOURCE point (SW3 switched to SOURCE)	±15%, Max. output current: 250mA (The sum of all loads connected)
	24VG	Common terminal of Digital signals Common point of digital signal SINK (SW3 switched to SINK)	
Analog input signal	+10V	Power for external speed potentiometer	+10V (Max. current , 20mA)
	-10V	Only above 200V 3HP/ 400V 5HP (include) support this terminal function	-10V (Max. current , 20mA)
	AI1	Multi-function analog input for speed reference (0-10V input)/(-10V~10V input)	From 0 to +10V, From -10V to +10V Input impedance : 20KΩ Resolution: 11bit + 1
	AI2	Multi-function analog input terminals *2, can use SW2 to switch voltage or current input (0~10V)/(4-20mA)	From 0 to +10V, From -10V to +10V Input impedance: 200KΩ From 4 to 20 mA Input impedance: 250KΩ Resolution: 11bit + 1
	GND	Analog signal ground terminal	----
	E	Shielding wire's connecting terminal (Ground)	----
Analog output signal	AO1	Multi-function analog output terminals *2 (0~10V output)	From 0 to 10V, From 4 to 20mA (Load < 500Ω) PWM Frequency: 10KHz
	AO2	Multi-function analog output terminals *2. can use SW6 to switch voltage or current input (0~10V / 4-20mA output)	
	GND	Analog signals ground terminal	
Pulse output signal	PO	Pulse output, Band width 32KHz, only above 200V 3HP/ 400V 5HP (include) support this terminal function.	Max. Frequency: 32KHz Open Collector output
	GND	Analog signals ground terminal	----