

Modicon TM3 Bus Coupler

Hardware Guide

EIO0000003635.06

03/2024



Legal Information

The information provided in this document contains general descriptions, technical characteristics and/or recommendations related to products/solutions.

This document is not intended as a substitute for a detailed study or operational and site-specific development or schematic plan. It is not to be used for determining suitability or reliability of the products/solutions for specific user applications. It is the duty of any such user to perform or have any professional expert of its choice (integrator, specifier or the like) perform the appropriate and comprehensive risk analysis, evaluation and testing of the products/solutions with respect to the relevant specific application or use thereof.

The Schneider Electric brand and any trademarks of Schneider Electric SE and its subsidiaries referred to in this document are the property of Schneider Electric SE or its subsidiaries. All other brands may be trademarks of their respective owner.

This document and its content are protected under applicable copyright laws and provided for informative use only. No part of this document may be reproduced or transmitted in any form or by any means (electronic, mechanical, photocopying, recording, or otherwise), for any purpose, without the prior written permission of Schneider Electric.

Schneider Electric does not grant any right or license for commercial use of the document or its content, except for a non-exclusive and personal license to consult it on an "as is" basis.

Schneider Electric reserves the right to make changes or updates with respect to or in the content of this document or the format thereof, at any time without notice.

To the extent permitted by applicable law, no responsibility or liability is assumed by Schneider Electric and its subsidiaries for any errors or omissions in the informational content of this document, as well as any non-intended use or misuse of the content thereof.

Table of Contents

Safety Information.....	5
Qualification of Personnel	5
Intended Use.....	6
About the Book.....	7
General Overview	12
TM3 Bus Couplers General Description	12
Maximum Hardware Configuration	13
TM2 General Description	15
TM3 General Description	17
Accessories	26
TM3 Bus Coupler Installation	28
TM3 Bus Coupler General Rules for Implementing.....	28
Environmental Characteristics	28
Certifications and Standards.....	30
TM3 Bus Coupler Installation.....	31
Installation and Maintenance Requirements.....	31
Installation Guidelines	32
Top Hat Section Rail (DIN rail).....	35
Assembling a Module to a Modicon TM3 Bus Coupler.....	36
Disassembling a Module from a Modicon TM3 Bus Coupler	37
Direct Mounting on a Panel Surface	38
TM3 Electrical Requirements.....	39
Wiring Best Practices	39
DC Power Supply Characteristics and Wiring.....	42
Grounding the TM3 System	44
TM3 Ethernet Bus Coupler	46
TM3 Ethernet Bus Coupler Presentation.....	46
TM3 Ethernet Bus Coupler Characteristics	48
Rotary Switch.....	49
Ethernet Port.....	52
Connecting the Modicon TM3 Bus Coupler to a PC	54
TM3 Modbus Serial Line Bus Coupler	56
TM3 Modbus Serial Line Bus Coupler Presentation.....	56
TM3 Modbus Serial Line Bus Coupler Characteristics	58
Rotary Switch.....	59
Serial Line Port.....	63
Connecting the TM3 Modbus Serial Line Bus Coupler to a PC	65
TM3 CANopen Bus Coupler.....	67
TM3 CANopen Bus Coupler Presentation.....	67
TM3 CANopen Bus Coupler Characteristics	70
Rotary Switch.....	71
CANopen Port.....	75
Connecting the TM3 CANopen Bus Coupler to a PC	77
Glossary	79
Index	81

Safety Information

Important Information

Read these instructions carefully, and look at the equipment to become familiar with the device before trying to install, operate, service, or maintain it. The following special messages may appear throughout this documentation or on the equipment to warn of potential hazards or to call attention to information that clarifies or simplifies a procedure.





The addition of this symbol to a “Danger” or “Warning” safety label indicates that an electrical hazard exists which will result in personal injury if the instructions are not followed.



This is the safety alert symbol. It is used to alert you to potential personal injury hazards. Obey all safety messages that follow this symbol to avoid possible injury or death.

 DANGER
DANGER indicates a hazardous situation which, if not avoided, will result in death or serious injury.

 WARNING
WARNING indicates a hazardous situation which, if not avoided, could result in death or serious injury.

 CAUTION
CAUTION indicates a hazardous situation which, if not avoided, could result in minor or moderate injury.

NOTICE
NOTICE is used to address practices not related to physical injury.

Please Note

Electrical equipment should be installed, operated, serviced, and maintained only by qualified personnel. No responsibility is assumed by Schneider Electric for any consequences arising out of the use of this material.

A qualified person is one who has skills and knowledge related to the construction and operation of electrical equipment and its installation, and has received safety training to recognize and avoid the hazards involved.

Qualification of Personnel

Only appropriately trained persons who are familiar with and understand the contents of this manual and all other pertinent product documentation are authorized to work on and with this product.

The qualified person must be able to detect possible hazards that may arise from parameterization, modifying parameter values and generally from mechanical, electrical, or electronic equipment. The qualified person must be familiar with the standards, provisions, and regulations for the prevention of industrial accidents, which they must observe when designing and implementing the system.

Intended Use

The products described or affected by this document, together with software, accessories, and options, are bus couplers, intended for industrial use according to the instructions, directions, examples, and safety information contained in the present document and other supporting documentation.

The product may only be used in compliance with all applicable safety regulations and directives, the specified requirements, and the technical data.

Prior to using the product, you must perform a risk assessment in view of the planned application. Based on the results, the appropriate safety-related measures must be implemented.

Since the product is used as a component in an overall machine or process, you must ensure the safety of persons by means of the design of this overall system.

Operate the product only with the specified cables and accessories. Use only genuine accessories and spare parts.

Any use other than the use explicitly permitted is prohibited and can result in unanticipated hazards.

About the Book

Document Scope

This guide describes the hardware implementation of Modicon TM3 Bus Couplers. It provides the description, characteristics, wiring diagrams, and installation details for Modicon TM3 Bus Couplers.

Validity Note

This document has been updated for the release of EcoStruxure™ Machine Expert V2.2.

This document has been updated for the release of EcoStruxure™ Machine Expert - Basic V1.3.

For product compliance and environmental information (RoHS, REACH, PEP, EOL, etc.), go to www.se.com/ww/en/work/support/green-premium/.

The characteristics of the products described in this document are intended to match the characteristics that are available on www.se.com. As part of our corporate strategy for constant improvement, we may revise the content over time to enhance clarity and accuracy. If you see a difference between the characteristics in this document and the characteristics on www.se.com, consider www.se.com to contain the latest information.

Available Languages of this Document

This document is available in these languages:

- English (EIO0000003635)
- French (EIO0000003636)
- German (EIO0000003637)
- Spanish (EIO0000003638)
- Italian (EIO0000003639)
- Chinese (EIO0000003640)
- Portuguese (EIO0000003641)
- Turkish (EIO0000003642)

Related Documents

Title of Documentation	Reference Number
Modicon TM3 Bus Coupler - Programming Guide (EcoStruxure Machine Expert)	EIO0000003643 (ENG) EIO0000003644 (FRA) EIO0000003645 (GER) EIO0000003646 (SPA) EIO0000003647 (ITA) EIO0000003648 (CHS) EIO0000003649 (POR) EIO0000003650 (TUR)
Modicon TM3 Bus Coupler (EcoStruxure Machine Expert - Basic) - Programming Guide	EIO0000004091(ENG) EIO0000004092 (FRA) EIO0000004093 (GER) EIO0000004094 (SPA) EIO0000004095 (ITA) EIO0000004096 (CHS) EIO0000004097 (POR) EIO0000004098 (TUR)
Modicon TM3 Expansion Modules Configuration - Programming Guide (EcoStruxure Machine Expert)	EIO0000003119 (ENG) EIO0000003120 (FRA) EIO0000003121 (GER) EIO0000003122 (SPA) EIO0000003123 (ITA) EIO0000003124 (CHS)
Modicon TM3 Bus Coupler IO Configurator Tool - User Guide	EIO0000004112 (ENG) EIO0000004113 (FRA) EIO0000004114 (GER) EIO0000004115 (SPA) EIO0000004116 (ITA) EIO0000004117 (CHS) EIO0000004118 (POR) EIO0000004119 (TUR)
CANopen Hardware Setup Manual	35010857 (ENG) 35010859 (FRA) 35010858 (GER) 35010860 (SPA) 35010861(ITA) 33004206 (CHS)
TM3 Ethernet Bus Coupler Instruction Sheet	PHA71490
TM3 Modbus Serial Line Bus Coupler Instruction Sheet	PHA71493
TM3 CANopen Bus Coupler Instruction Sheet	PHA71492

To find documents online, visit the Schneider Electric download center (www.se.com/ww/en/download/).

Product Related Information

DANGER

HAZARD OF ELECTRIC SHOCK, EXPLOSION OR ARC FLASH

- Disconnect all power from all equipment including connected devices prior to removing any covers or doors, or installing or removing any accessories, hardware, cables, or wires except under the specific conditions specified in the appropriate hardware guide for this equipment.
- Always use a properly rated voltage sensing device to confirm the power is off where and when indicated.
- Replace and secure all covers, accessories, hardware, cables, and wires and confirm that a proper ground connection exists before applying power to the unit.
- Use only the specified voltage when operating this equipment and any associated products.

Failure to follow these instructions will result in death or serious injury.

DANGER

POTENTIAL FOR EXPLOSION

- Only use this equipment in non-hazardous locations, or in locations that comply with Class I, Division 2, Groups A, B, C and D.
- Do not substitute components which would impair compliance to Class I, Division 2.
- Do not connect or disconnect equipment unless power has been removed or the location is known to be non-hazardous.
- Do not use the USB port(s), if so equipped, unless the location is known to be non-hazardous.

Failure to follow these instructions will result in death or serious injury.

▲ WARNING**LOSS OF CONTROL**

- Perform a Failure Mode and Effects Analysis (FMEA), or equivalent risk analysis, of your application, and apply preventive and detective controls before implementation.
- Provide a fallback state for undesired control events or sequences.
- Provide separate or redundant control paths wherever required.
- Supply appropriate parameters, particularly for limits.
- Review the implications of transmission delays and take actions to mitigate them.
- Review the implications of communication link interruptions and take actions to mitigate them.
- Provide independent paths for control functions (for example, emergency stop, over-limit conditions, and error conditions) according to your risk assessment, and applicable codes and regulations.
- Apply local accident prevention and safety regulations and guidelines.¹
- Test each implementation of a system for proper operation before placing it into service.

Failure to follow these instructions can result in death, serious injury, or equipment damage.

¹ For additional information, refer to NEMA ICS 1.1 (latest edition), *Safety Guidelines for the Application, Installation, and Maintenance of Solid State Control* and to NEMA ICS 7.1 (latest edition), *Safety Standards for Construction and Guide for Selection, Installation and Operation of Adjustable-Speed Drive Systems* or their equivalent governing your particular location.

▲ WARNING**UNINTENDED EQUIPMENT OPERATION**

- Only use software approved by Schneider Electric for use with this equipment.
- Update your application program every time you change the physical hardware configuration.

Failure to follow these instructions can result in death, serious injury, or equipment damage.

Information on Non-Inclusive or Insensitive Terminology

As a responsible, inclusive company, Schneider Electric is constantly updating its communications and products that contain non-inclusive or insensitive terminology. However, despite these efforts, our content may still contain terms that are deemed inappropriate by some customers.

Terminology Derived from Standards

The technical terms, terminology, symbols and the corresponding descriptions in the information contained herein, or that appear in or on the products themselves, are generally derived from the terms or definitions of international standards.

In the area of functional safety systems, drives and general automation, this may include, but is not limited to, terms such as *safety*, *safety function*, *safe state*, *fault*, *fault reset*, *malfunction*, *failure*, *error*, *error message*, *dangerous*, etc.

Among others, these standards include:

Standard	Description
IEC 61131-2:2007	Programmable controllers, part 2: Equipment requirements and tests.
ISO 13849-1:2023	Safety of machinery: Safety related parts of control systems. General principles for design.
EN 61496-1:2013	Safety of machinery: Electro-sensitive protective equipment. Part 1: General requirements and tests.
ISO 12100:2010	Safety of machinery - General principles for design - Risk assessment and risk reduction
EN 60204-1:2006	Safety of machinery - Electrical equipment of machines - Part 1: General requirements
ISO 14119:2013	Safety of machinery - Interlocking devices associated with guards - Principles for design and selection
ISO 13850:2015	Safety of machinery - Emergency stop - Principles for design
IEC 62061:2021	Safety of machinery - Functional safety of safety-related electrical, electronic, and electronic programmable control systems
IEC 61508-1:2010	Functional safety of electrical/electronic/programmable electronic safety-related systems: General requirements.
IEC 61508-2:2010	Functional safety of electrical/electronic/programmable electronic safety-related systems: Requirements for electrical/electronic/programmable electronic safety-related systems.
IEC 61508-3:2010	Functional safety of electrical/electronic/programmable electronic safety-related systems: Software requirements.
IEC 61784-3:2021	Industrial communication networks - Profiles - Part 3: Functional safety fieldbuses - General rules and profile definitions.
2006/42/EC	Machinery Directive
2014/30/EU	Electromagnetic Compatibility Directive
2014/35/EU	Low Voltage Directive

In addition, terms used in the present document may tangentially be used as they are derived from other standards such as:

Standard	Description
IEC 60034 series	Rotating electrical machines
IEC 61800 series	Adjustable speed electrical power drive systems
IEC 61158 series	Digital data communications for measurement and control – Fieldbus for use in industrial control systems

Finally, the term *zone of operation* may be used in conjunction with the description of specific hazards, and is defined as it is for a *hazard zone* or *danger zone* in the *Machinery Directive (2006/42/EC)* and *ISO 12100:2010*.

NOTE: The aforementioned standards may or may not apply to the specific products cited in the present documentation. For more information concerning the individual standards applicable to the products described herein, see the characteristics tables for those product references.

General Overview

TM3 Bus Couplers General Description

Introduction

The Modicon TM3 bus couplers are devices designed to manage EtherNet/IP, Modbus TCP, Modbus serial line or CANopen communications, depending on the reference, in association with TM2/TM3 I/O expansion modules in a distributed architecture.

Software configuration is accomplished with:

- The EcoStruxure Machine Expert software (refer to the Modicon TM3 Bus Coupler - Programming Guide).
- The EcoStruxure Machine Expert - Basic software (refer to the Modicon TM3 Bus Coupler (EcoStruxure Machine Expert - Basic) - Programming Guide).
- The Configuration software tool (see Modicon TM3 Bus Coupler IO Configurator).

Modicon TM3 Bus Couplers

The following table shows the TM3 bus couplers, with ports and terminal types:

Reference	Port	Communication type	Terminal type
TM3BCEIP, page 46	2 isolated switched Ethernet ports	EtherNet/IP Modbus TCP	RJ45
	1 USB port	USB 2.0	USB mini-B
TM3BCSL, page 56	2 isolated RS-485 ports (daisy-chained)	Serial Line Modbus	RJ45
	1 USB port	USB 2.0	USB mini-B
TM3BCCO, page 67	2 isolated CANopen ports (daisy-chained)	CANopen	RJ45
	1 USB port	USB 2.0	USB mini-B

Maximum Hardware Configuration

Distributed Configuration Principle

The following illustration defines an example of a distributed configuration using a TM3BCEIP with a controller:

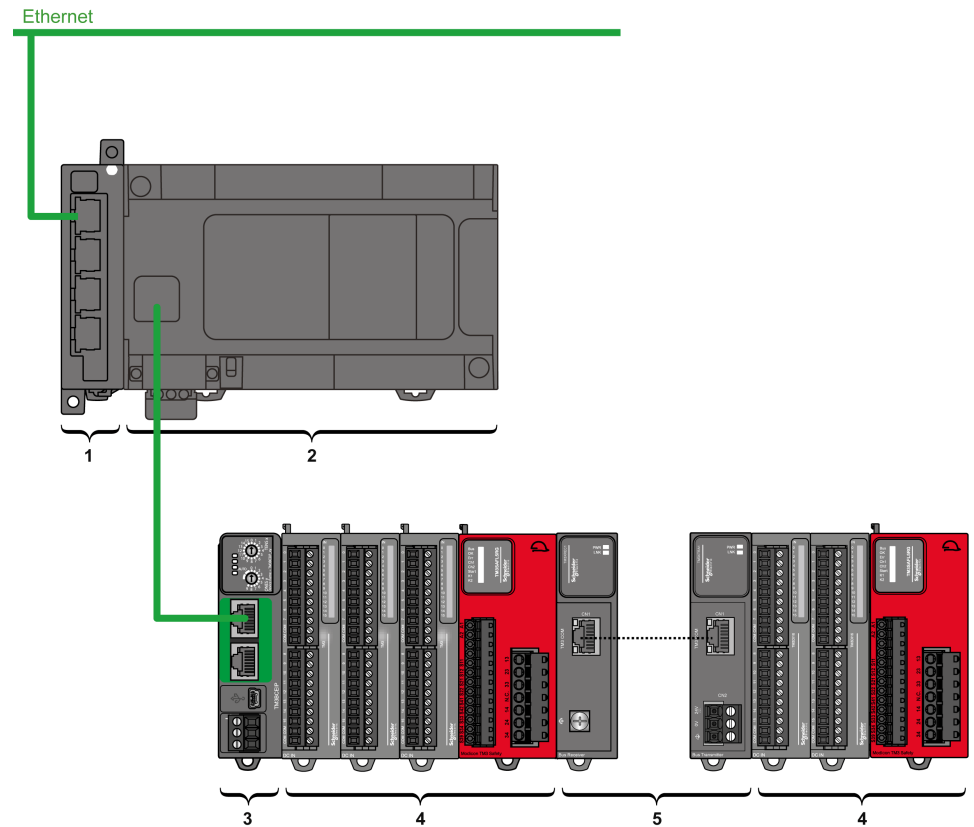

- 1 Communication expansion module
- 2 Controller
- 3 TM3 bus coupler
- 4 TM3 expansion modules
- 5 TM3 transmitter and receiver

TM3 Bus Coupler Distributed Configuration Architecture

Optimized distributed configuration and flexibility are provided by the association of:

- Controller
- TM3 bus coupler
- TM3 expansion modules
- TM2 expansion modules

The following illustration is an example of an association:

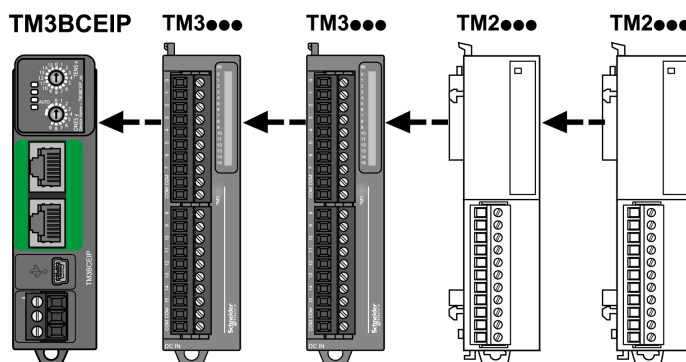

NOTE: Do not mount a TM2 module before any TM3 module as indicated in the following illustration:

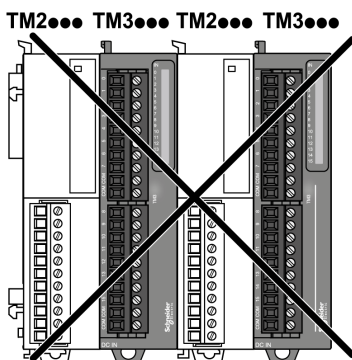

Maximum Number of Modules

Each TM3 bus coupler supports up to:

Module type	Maximum number of modules
TM2	7
TM2 - TM3	7
TM3	7 without transmitter and receiver. 14 with transmitter and receiver.

NOTE: EcoStruxure Machine Expert and EcoStruxure Machine Expert - Basic software validate the configuration to the extent possible. However, although EcoStruxure Machine Expert may allow certain configurations, the maximum configuration populated by high energy consuming modules, coupled with the maximum distance allowable between the TM3 transmitter and receiver modules, may present bus communication issues in some environments. If this occurs, you will need to analyze the energy consumption of the modules chosen for your configuration, minimize the cable distance required by your application, and otherwise consider optimizing your choices.

TM2 General Description

Introduction

The range of TM2 expansion modules includes:

- Digital expansion modules
- Analog expansion modules

Digital Expansion Modules Features

The following table shows the digital expansion modules features:

Module reference	Channels	Channel type	Voltage/current	Reference page
Input Modules				
TM2DAI8DT	8	Inputs	120 Vac 7.5 mA	TM2DAI8DT
TM2DDI8DT	8	Inputs	24 Vdc 7 mA	TM2DDI8DT
TM2DDI16DT	16	Inputs	24 Vdc 7 mA	TM2DDI16DT
TM2DDI16DK	16	Inputs	24 Vdc 5 mA	TM2DDI16DK
TM2DDI32DK	32	Inputs	24 Vdc 5 mA	TM2DDI32DK
Output Modules				
TM2DRA8RT	8	Outputs Relay	30 Vdc/230 Vac 2 A max	TM2DRA8RT
TM2DRA16RT	16	Outputs Relay	30 Vdc/230 Vac 2 A max	TM2DRA16RT
TM2DDO8UT	8	Outputs Transistor sink	24 Vdc 0.3 A max per output	TM2DDO8UT
TM2DDO8TT	8	Outputs Transistor source	24 Vdc 0.5 A max per output	TM2DDO8TT
TM2DDO16UK	16	Outputs Transistor sink	24 Vdc 0.1 A max per output	TM2DDO16UK
TM2DDO16TK	16	Outputs Transistor source	24 Vdc 0.4 A max per output	TM2DDO16TK
TM2DDO32UK	32	Outputs Transistor sink	24 Vdc 0.1 A max per output	TM2DDO32UK
TM2DDO32TK	32	Outputs Transistor source	24 Vdc 0.4 A max per output	TM2DDO32TK
Mixed Modules				
TM2DMM8DRT	4	Inputs	24 Vdc/7 mA	TM2DMM8DRT
	4	Outputs	30 Vdc/230VAC	
		Relay	2 A max	
TM2DMM24DRF	16	Inputs	24 Vdc/7 mA	TM2DMM24DRF
	8	Outputs	30 Vdc/230VAC	
		Relay	2 A max	

Analog Expansion Modules Features

The following table shows the analog expansion modules features:

Module reference	Channels	Channel type	Voltage/current	Reference page
Input Modules				
TM2AMI2HT	2	High-level inputs	0...10 Vdc 4...20 mA	TM2AMI2HT
TM2AMI2LT	2	Low-level inputs	Thermocouple type J,K,T	TM2AMI2LT
TM2AMI4LT	4	Inputs	0...10 Vdc 0...20 mA PT100/1000 Ni100/1000	TM2AMI4LT
TM2AMI8HT	8	Inputs	0...20 mA 0...10 Vdc	TM2AMI8HT
TM2ARI8HT	8	Inputs	NTC / PTC	TM2ARI8HT (see Modicon TM2, Modules Configuration, Programming Guide)
TM2ARI8LRJ	8	Inputs	PT100/1000	TM2ARI8LRJ
TM2ARI8LT	8	Inputs	PT100/1000	TM2ARI8LT
Output Modules				
TM2AMO1HT	1	Outputs	0...10 Vdc 4...20 mA	TM2AMO1HT
TM2AVO2HT	2	Outputs	+/- 10 Vdc	TM2AVO2HT
Mixed Modules				
TM2AMM3HT	2	Inputs	0...10 Vdc 4...20 mA 0...10 Vdc 4...20 mA	TM2AMM3HT
	1	Outputs		
TM2AMM6HT	4	Inputs	0...10 Vdc 4...20 mA 0...10 Vdc 4...20 mA	TM2AMM6HT
	2	Outputs		
TM2ALM3LT	2	Low-level inputs	Thermo J,K,T, PT100 0...10 Vdc 4...20 mA	TM2ALM3LT
	1	Outputs		

TM3 General Description

Introduction

The range of TM3 expansion modules includes:

- Digital modules, classified as follows:
 - Input modules, page 17
 - Output modules, page 18
 - Mixed input/output modules, page 20
- Analog modules, classified as follows:
 - Input modules, page 21
 - Output modules, page 22
 - Mixed input/output modules, page 23
- Expert modules, page 24
- Transmitter and receiver modules, page 24
- Safety modules, page 25

TM3 Digital Input Modules

The following table shows the TM3 digital input expansion modules, with corresponding channel type, nominal voltage/current, and terminal type. For information on configuration of these modules, refer to the TM3 Digital I/O Modules Configuration section.

Reference	Channels	Channel Type	Voltage Current	Terminal Type / Pitch
TM3DI8A	8	Regular inputs	120 Vac 7.5 mA	Removable screw terminal block / 5.08 mm
TM3DI8	8	Regular inputs	24 Vdc 7 mA	Removable screw terminal block / 5.08 mm
TM3DI8G	8	Regular inputs	24 Vdc 7 mA	Removable spring terminal block / 5.08 mm
TM3DI16	16	Regular inputs	24 Vdc 7 mA	Removable screw terminal block / 3.81 mm
TM3DI16G	16	Regular inputs	24 Vdc 7 mA	Removable spring terminal block / 3.81 mm
TM3DI16K	16	Regular inputs	24 Vdc 5 mA	HE10 (MIL 20) connector
TM3DI32K	32	Regular inputs	24 Vdc 5 mA	HE10 (MIL 20) connector

TM3 Digital Output Modules

The following table shows the TM3 digital output modules, with corresponding channel type, nominal voltage/current, and terminal type. For information on configuration of these modules, refer to the TM3 Digital I/O Modules Configuration section.

Reference	Channels	Channel Type	Voltage Current	Terminal Type / Pitch
TM3DQ8R	8	Relay outputs	24 Vdc / 240 Vac 7 A maximum per common line / 2 A maximum per output	Removable screw terminal block / 5.08 mm
TM3DQ8RG	8	Relay outputs	24 Vdc / 240 Vac 7 A maximum per common line / 2 A maximum per output	Removable spring terminal block / 5.08 mm
TM3DQ8T	8	Regular transistor outputs (source)	24 Vdc 4 A maximum per common line/0.5 A maximum per output	Removable screw terminal block / 5.08 mm
TM3DQ8TG	8	Regular transistor outputs (source)	24 Vdc 4 A maximum per common line/0.5 A maximum per output	Removable spring terminal block / 5.08 mm
TM3DQ8U	8	Regular transistor outputs (sink)	24 Vdc 4 A maximum per common line/0.5 A maximum per output	Removable screw terminal block / 5.08 mm
TM3DQ8UG	8	Regular transistor outputs (sink)	24 Vdc 4 A maximum per common line/0.5 A maximum per output	Removable spring terminal block / 5.08 mm
TM3DQ16R	16	Relay outputs	24 Vdc / 240 Vac 8 A maximum per common line / 2 A maximum per output	Removable screw terminal block / 3.81 mm
TM3DQ16RG	16	Relay outputs	24 Vdc / 240 Vac 8 A maximum per common line / 2 A maximum per output	Removable spring terminal block / 3.81 mm
TM3DQ16T	16	Regular transistor outputs (source)	24 Vdc 4 A maximum per common line / 0.5 A maximum per output	Removable screw terminal block / 3.81 mm
TM3DQ16TG	16	Regular transistor outputs (source)	24 Vdc 4 A maximum per common line / 0.5 A maximum per output	Removable spring terminal block / 3.81 mm
TM3DQ16U	16	Regular transistor outputs (sink)	24 Vdc 2 A maximum per common line / 0.3 A maximum per output	Removable screw terminal block / 3.81 mm
TM3DQ16UG	16	Regular transistor outputs (sink)	24 Vdc 2 A maximum per common line / 0.3 A maximum per output	Removable spring terminal block / 3.81 mm
TM3DQ16TK	16	Regular transistor outputs (source)	24 Vdc 2 A maximum per common line / 0.1 A maximum per output	HE10 (MIL 20) connector

Reference	Channels	Channel Type	Voltage Current	Terminal Type / Pitch
TM3DQ16UK	16	Regular transistor outputs (sink)	24 Vdc 2 A maximum per common line / 0.1 A maximum per output	HE10 (MIL 20) connector
TM3DQ32TK	32	Regular transistor outputs (source)	24 Vdc 2 A maximum per common line / 0.1 A maximum per output	HE10 (MIL 20) connector
TM3DQ32UK	32	Regular transistor outputs (sink)	24 Vdc 2 A maximum per common line / 0.1 A maximum per output	HE10 (MIL 20) connector

TM3 Digital Mixed Input/Output Modules

This following table shows the TM3 mixed I/O modules, with corresponding channel type, nominal voltage/current, and terminal type. For information on configuration of these modules, refer to the TM3 Digital I/O Modules Configuration section.

Reference	Channels	Channel Type	Voltage Current	Terminal Type / Pitch
TM3DM8R	4	Regular inputs	24 Vdc 7 mA	Removable screw terminal block / 5.08 mm
	4	Relay outputs	24 Vdc / 240 Vac 7 A maximum per common line / 2 A maximum per output	
TM3DM8RG	4	Regular inputs	24 Vdc 7 mA	Removable spring terminal block / 5.08 mm
	4	Relay outputs	24 Vdc / 240 Vac 7 A maximum per common line / 2 A maximum per output	
TM3DM16R ⁽¹⁾	8	Regular inputs	24 Vdc 5 mA	Removable screw terminal block / 3.81 mm
	8	Relay outputs	24 Vdc / 240 Vac 4 A maximum per common line / 2 A maximum per output	
TM3DM24R	16	Regular inputs	24 Vdc 7 mA	Removable screw terminal block / 3.81 mm
	8	Relay outputs	24 Vdc / 240 Vac 7 A maximum per common line / 2 A maximum per output	
TM3DM24RG	16	Regular inputs	24 Vdc 7 mA	Removable spring terminal block / 3.81 mm
	8	Relay outputs	24 Vdc / 240 Vac 7 A maximum per common line / 2 A maximum per output	
TM3DM32R ⁽¹⁾	16	Regular inputs	24 Vdc 5 mA	Removable screw terminal block / 3.81 mm
	16	Relay outputs	24 Vdc / 240 Vac 4 A maximum per common line / 2 A maximum per output	

(1) This expansion module is available only in selected countries and it is only supported by TM3BCEIP in EcoStruxure Machine Expert V2.0.2 software and later.

TM3 Analog Input Modules

The following table shows the TM3 analog input expansion modules, with corresponding channel type, nominal voltage/current, and terminal type. For information on configuration of these modules, refer to the TM3 Analog Input Modules Configuration section.

Reference	Resolution	Channels	Channel Type	Mode	Terminal Type / Pitch
TM3AI2H	16 bit, or 15 bit + sign	2	inputs	0...10 Vdc -10...+10 Vdc 0...20 mA 4...20 mA	Removable screw terminal block / 5.08 mm
TM3AI2HG	16 bit, or 15 bit + sign	2	inputs	0...10 Vdc -10...+10 Vdc 0...20 mA 4...20 mA	Removable spring terminal block / 5.08 mm
TM3AI4	12 bit, or 11 bit + sign	4	inputs	0...10 Vdc -10...+10 Vdc 0...20 mA 4...20 mA	Removable screw terminal block / 3.81 mm
TM3AI4G	12 bit, or 11 bit + sign	4	inputs	0...10 Vdc -10...+10 Vdc 0...20 mA 4...20 mA	Removable spring terminal blocks / 3.81 mm
TM3AI8	12 bit, or 11 bit + sign	8	inputs	0...10 Vdc -10...+10 Vdc 0...20 mA 4...20 mA 0...20 mA extended 4...20 mA extended	Removable screw terminal block / 3.81 mm
TM3AI8G	12 bit, or 11 bit + sign	8	inputs	0...10 Vdc -10...+10 Vdc 0...20 mA 4...20 mA 0...20 mA extended 4...20 mA extended	Removable spring terminal blocks / 3.81 mm
TM3TI4	16 bit, or 15 bit + sign	4	inputs	0...10 Vdc -10...+10 Vdc 0...20 mA 4...20 mA Thermocouple PT100/1000 NI100/1000	Removable screw terminal block / 3.81 mm

Reference	Resolution	Channels	Channel Type	Mode	Terminal Type / Pitch
TM3TI4G	16 bit, or 15 bit + sign	4	inputs	0...10 Vdc -10...+10 Vdc 0...20 mA 4...20 mA Thermocouple PT100/1000 NI100/1000	Removable spring terminal blocks / 3.81 mm
TM3TI4D	16 bit, or 15 bit + sign	4	inputs	Thermocouple	Removable screw terminal block / 3.81 mm
TM3TI4DG	16 bit, or 15 bit + sign	4	inputs	Thermocouple	Removable spring terminal blocks / 3.81 mm
TM3TI8T	16 bit, or 15 bit + sign	8	inputs	Thermocouple NTC/PTC	Removable screw terminal block / 3.81 mm
TM3TI8TG	16 bit, or 15 bit + sign	8	inputs	Thermocouple NTC/PTC	Removable spring terminal blocks / 3.81 mm

TM3 Analog Output Modules

The following table shows the TM3 analog output modules, with corresponding channel type, nominal voltage/current, and terminal type. For information on configuration of these modules, refer to the TM3 Analog Output Modules Configuration section.

Reference	Resolution	Channels	Channel Type	Mode	Terminal Type / Pitch
TM3AQ2	12 bit, or 11 bit + sign	2	outputs	0...10 Vdc -10...+10 Vdc 0...20 mA 4...20 mA	Removable screw terminal block / 5.08 mm
TM3AQ2G	12 bit, or 11 bit + sign	2	outputs	0...10 Vdc -10...+10 Vdc 0...20 mA 4...20 mA	Removable spring terminal block / 5.08 mm
TM3AQ4	12 bit, or 11 bit + sign	4	outputs	0...10 Vdc -10...+10 Vdc 0...20 mA 4...20 mA	Removable screw terminal block / 5.08 mm
TM3AQ4G	12 bit, or 11 bit + sign	4	outputs	0...10 Vdc -10...+10 Vdc 0...20 mA 4...20 mA	Removable spring terminal block / 5.08 mm

TM3 Analog Mixed Input/Output Modules

The following table shows the TM3 analog mixed I/O modules, with corresponding channel type, nominal voltage/current, and terminal type. For information on configuration of these modules, refer to the TM3 Analog Mixed I/O Modules Configuration section.

Reference	Resolution	Channels	Channel Type	Mode	Terminal Type / Pitch
TM3AM6	12 bit, or 11 bit + sign	4	inputs	0...10 Vdc	Removable screw terminal block / 3.81 mm
		2	outputs	-10...+10 Vdc 0...20 mA 4...20 mA	
TM3AM6G	12 bit, or 11 bit + sign	4	inputs	0...10 Vdc	Removable spring terminal block / 3.81 mm
		2	outputs	-10...+10 Vdc 0...20 mA 4...20 mA	
TM3TM3	16 bit, or 15 bit + sign	2	inputs	0...10 Vdc -10...+10 Vdc 0...20 mA 4...20 mA Thermocouple PT100/1000 NI100/1000	Removable screw terminal block / 5.08 mm
	12 bit, or 11 bit + sign	1	output	0...10 Vdc -10...+10 Vdc 0...20 mA 4...20 mA	
TM3TM3G	16 bit, or 15 bit + sign	2	inputs	0...10 Vdc -10...+10 Vdc 0...20 mA 4...20 mA Thermocouple PT100/1000 NI100/1000	Removable spring terminal block / 5.08 mm
	12 bit, or 11 bit + sign	1	output	0...10 Vdc -10...+10 Vdc 0...20 mA 4...20 mA	

TM3 Expert Modules

The following table shows the TM3 expert expansion modules, with corresponding terminal type. For information on configuration of these modules, refer to the TM3 Expert I/O Modules Configuration section.

Reference	Description	Terminal Type / Pitch
TM3XTYS4	TeSys module	4 front connectors RJ-45 1 removable power supply connector / 5.08 mm

TM3 Transmitter and Receiver Modules

The following table shows the TM3 transmitter and receiver expansion modules, with corresponding terminal type. For information on configuration of these modules, refer to the TM3 Transmitter and Receiver I/O Modules Configuration section.

Reference	Description	Terminal Type / Pitch
TM3XTRA1	Data transmitter module for remote I/O	1 front connector RJ-45 1 screw for functional ground connection
TM3XREC1	Data receiver module for remote I/O	1 front connector RJ-45 1 removable power supply connector / 5.08 mm

TM3 Safety Modules

This table contains the TM3 safety modules, with the corresponding channel type, nominal voltage/current, and terminal type:

Reference	Function Category	Channels	Channel type	Voltage Current	Terminal type
TM3SAC5R	1 function, up to category 3	1 or 2 ⁽¹⁾	Safety input	24 Vdc	3.81 mm (0.15 in.) and 5.08 mm (0.20 in.), removable screw terminal block
		Start ⁽²⁾	Input	100 mA maximum	
		3 in parallel	Relay outputs Normally open	24 Vdc / 230 Vac 6 A maximum per output	
TM3SAC5RG	1 function, up to category 3	1 or 2 ⁽¹⁾	Safety input	24 Vdc	3.81 mm (0.15 in.) and 5.08 mm (0.20 in.), removable spring terminal block
		Start ⁽²⁾	Input	100 mA maximum	
		3 in parallel	Relay outputs Normally open	24 Vdc / 230 Vac 6 A maximum per output	
TM3SAF5R	1 function, up to category 4	2 ⁽¹⁾	Safety inputs	24 Vdc	3.81 mm (0.15 in.) and 5.08 mm (0.20 in.), removable screw terminal block
		Start	Input	100 mA maximum	
		3 in parallel	Relay outputs Normally open	24 Vdc / 230 Vac 6 A maximum per output	
TM3SAF5RG	1 function, up to category 4	2 ⁽¹⁾	Safety inputs	24 Vdc	3.81 mm (0.15 in.) and 5.08 mm (0.20 in.), removable spring terminal block
		Start	Input	100 mA maximum	
		3 in parallel	Relay outputs Normally open	24 Vdc / 230 Vac 6 A maximum per output	
TM3SAFL5R	2 functions, up to category 3	2 ⁽¹⁾	Safety inputs	24 Vdc	3.81 mm (0.15 in.) and 5.08 mm (0.20 in.), removable screw terminal block
		Start	Input	100 mA maximum	
		3 in parallel	Relay outputs Normally open	24 Vdc / 230 Vac 6 A maximum per output	
TM3SAFL5RG	2 functions, up to category 3	2 ⁽¹⁾	Safety inputs	24 Vdc	3.81 mm (0.15 in.) and 5.08 mm (0.20 in.), removable spring terminal block
		Start	Input	100 mA maximum	
		3 in parallel	Relay outputs Normally open	24 Vdc / 230 Vac 6 A maximum per output	
TM3SAK6R	3 functions, up to category 4	1 or 2 ⁽¹⁾	Safety inputs	24 Vdc	3.81 mm (0.15 in.) and 5.08 mm (0.20 in.), removable screw terminal block
		Start	Input	100 mA maximum	
		3 in parallel	Relay outputs Normally open	24 Vdc / 230 Vac 6 A maximum per output	
TM3SAK6RG	3 functions, up to category 4	1 or 2 ⁽¹⁾	Safety inputs	24 Vdc	3.81 mm (0.15 in.) and 5.08 mm (0.20 in.), removable spring terminal block
		Start	Input	100 mA maximum	
		3 in parallel	Relay outputs Normally open	24 Vdc / 230 Vac 6 A maximum per output	

⁽¹⁾ Depending on external wiring
⁽²⁾ Non-monitored start

Accessories

Overview

This section describes the accessories and cables.

Accessories

Reference	Description	Use	Quantity
NSYTRAAB35	End brackets	Helps secure the TM3 bus coupler and their expansion modules on a top hat section rail (DIN rail).	1
TMAM2	Mounting kit	Mounts the TM3 bus coupler directly to a flat, vertical panel.	
VW3A8306RC	Modbus line terminator	Terminate the end of RS-485 line.	2
TCSCAR013M120	CANopen line terminator (RJ45)	Terminate the end of CAN bus.	
VW3CANA71	CANopen adaptor	CANopen adaptor for converting SUB-D to RJ45.	1

For top hat section rails (DIN rails), refer to Top Hat Section Rail (DIN rail), page 35.

Cables

Reference	Description	Details	Length
TCSXCNAMUM3P	Terminal port/USB port cordset	From the USB mini-B port on the bus coupler to USB port on the PC terminal.	3 m (10 ft)
BMXXCAUSBH018		From the USB mini-B port on the bus coupler to USB port on the PC terminal. NOTE: Grounded and shielded, this USB cable is suitable for long-duration connections.	1.8 m (5.9 ft)
TSXCSA***	Modbus cable for RS485	Cable equipped with 4 twisted shielded wires.	100, 200 or 500 m (328.08, 656.16 or 1.640.42 ft)
VW3A8306R**	Modbus serial line cable	Cable equipped with 2 RJ45 connectors for Ethernet network, Modbus serial line, XBTGT terminal.	0.3, 1 or 3 m (0.98, 3.28 or 9.84 ft)
XBTZ998•		Cable equipped with 2 RJ45 connectors for XBT terminal.	2.5 or 10 m (8.2 or 32.81 ft)
XBTZ9008		Cable equipped with 1 RJ45 connector and 1 SUB-D 9 for XBT terminal.	2.5 m (8.2 ft)
VW3A8306D**		Cable equipped with 1 RJ45 connector and 1 free end.	3 m (9.84 ft)
TWDXCAFJ010		Cable equipped with 1 RJ45 connector and 1 free end.	1 m (3.28 ft)
490NTW000**		Ethernet shielded cable for DTE connections	Standard cable, equipped with RJ45 connectors at each end for DTE. CE compliant.
490NTW000**U	Standard cable, equipped with RJ45 connectors at each end for DTE. UL compliant.		
TCSECE3M3M**S4		Cable for harsh environment, equipped with RJ45 connectors at each end. CE compliant.	1, 2, 3, 5, or 10 m (3.28, 6.56, 9.84, 16.4, 32.81 ft)
TCSECU3M3M**S4		Cable for harsh environment, equipped with RJ45 connectors at each end. UL compliant.	
TSXCANCA***	CANopen cable	CANopen standard cable. CE compliant	50, 100 or 300 m (164.04, 328.08 or 984.25 ft)
TSXCANCB***		CANopen standard cable. CE and UL compliant.	
TSXCANCD***		CANopen cable for harsh environment. CE compliant.	
TCSCCN4F3M**T	CANopen preassembled cordsets	CANopen standard cable equipped with 1 RJ45 connector and 1 SUB-D 9 connector.	0.5, 1 or 3 m (1.64, 3.28 or 9.84 ft)
VW3M3805R***			1 or 3 m (3.28 or 9.84 ft)
VW3CANCARR**		CANopen standard cable, equipped with RJ45 connectors at each end.	0.3 or 1 m (0.984 or 3.28 ft)

TM3 Bus Coupler Installation

TM3 Bus Coupler General Rules for Implementing

Environmental Characteristics

Enclosure Requirements

Modicon TM3 Bus Coupler components are designed as Zone B, Class A industrial equipment according to IEC/CISPR Publication 11. If they are used in environments other than those described in these standards, or in environments that do not meet the specifications in this manual the ability to meet electromagnetic compatibility requirements in the presence of conducted and/or radiated interference may be reduced.

All Modicon TM3 Bus Coupler components meet UL requirement for open equipment as defined by UL 61010-1 and UL 61010-2-201. You must install them in an enclosure that conforms to UL 61010-1 and UL 61010-2-201 and designed for the specific environmental conditions and to minimize the possibility of unintended contact with hazardous voltages. The enclosure must have protection against the spread of fire and adequate rigidity to conform to UL 61010-1 and UL 61010-2-201. Use metal enclosures to improve the electromagnetic immunity of your Modicon TM3 Bus Coupler components. Use enclosures with a keyed locking mechanism to minimize unauthorized access.

Environmental Characteristics

This equipment meets CE requirements as indicated in the table below. This equipment is intended for use in a Pollution Degree 2 industrial environment. This equipment is intended for indoor use only.

⚠ WARNING

UNINTENDED EQUIPMENT OPERATION

Do not exceed any of the rated values specified in the environmental and electrical characteristics tables.

Failure to follow these instructions can result in death, serious injury, or equipment damage.

The following table shows the general environmental characteristics:

Characteristic	Minimum Specification	Tested Range	
Standard compliance	IEC/EN 61131-2 IEC/EN 61010-1, 2-201	–	
Ambient operating temperature	–	Horizontal installation	–10...60 °C (14...140 °F)
	–	Vertical installation	–10...50 °C (14...122 °F)
Storage temperature	–	–25...70 °C (- 13...158 °F)	
Relative humidity	–	Transport and storage	10...95 % (non-condensing)
		Operation	10...95 % (non-condensing)
Degree of pollution	IEC/EN 60664-1	2	
Pollution degree	IEC/UL 61010-1	Pollution degree 2, overvoltage category 2	
Degree of protection	IEC/EN 61131-2	IP20	
Corrosion immunity	–	Atmosphere free from corrosive gases	
Operating altitude	–	0...2000 m (0...6560 ft)	
Storage altitude	–	0...3000 m (0...9843 ft)	
Vibration resistance	IEC/EN 61131-2	Panel mounting or mounted on a top hat section rail (DIN rail)	3.5 mm (0.13 in) fixed amplitude from 5...8.4 Hz 9.8 m/s ² (32.15 ft/s ²) (1 g _n) fixed acceleration from 8.4...150 Hz
Mechanical shock resistance	–	147 m/s ² or 482.28 ft/s ² (15 g _n) for a duration of 11 ms	
<p>NOTE: The tested ranges may indicate values beyond that of the IEC Standard. However, our internal standards define what is necessary for industrial environments. In all cases, we uphold the minimum specification if indicated.</p>			

Electromagnetic Susceptibility

The expansion module components and the TM3 bus coupler meet electromagnetic susceptibility specifications as indicated in the following table:

Characteristic	Minimum Specification	Tested Range		
Electrostatic discharge	IEC/EN 61000-4-2	8 kV (air discharge) 4 kV (contact discharge)		
Radiated electromagnetic field	IEC/EN 61000-4-3	10 V/m (80...1000 MHz) 3 V/m (1.4...2 GHz) 3 V/m (2...2.7 GHz) 3 V/m (2.7...6 GHz)		
Magnetic field	IEC/EN 61000-4-8	30 A/m 50 Hz, 60 Hz		
Fast transients burst	IEC/EN 61000-4-4	DC Power lines	2 kV	
		Controls and signals	1 kV	
Surge immunity	IEC/EN 61000-4-5	–	CM ¹	DM ²
		DC Power lines	1 kV	0.5 kV
	IEC/EN 61131-2	Controls and signals	1 kV	–
		Communication line	1 kV	–
Induced electromagnetic field	IEC/EN 61000-4-6	10 Vrms (0.15...80 MHz)		
Conducted emission	IEC/EN 61000-6-4	AC/DC power line: <ul style="list-style-type: none"> • 10...150 kHz: 120...69 dBμV/m QP • 150...1500 kHz: 79...63 dBμV/m QP • 1.5...30 MHz: 63 dBμV/m QP 		
Radiated emission	IEC/EN 61000-6-4	30...230 MHz: 40 dB μ V/m QP 230...1000 MHz: 47 dB μ V/m QP		
1 Common Mode 2 Differential Mode NOTE: The tested ranges may indicate values beyond that of the IEC Standard. However, our internal standards define what is necessary for industrial environments. In all cases, we uphold the minimum specification if indicated.				

Certifications and Standards

Introduction

For information on certifications and conformance to standards, go to www.se.com.

For product compliance and environmental information (RoHS, REACH, PEP, EOL, etc.), go to www.se.com/green-premium.

TM3 Bus Coupler Installation

Installation and Maintenance Requirements

Before Starting

Read and understand this chapter before beginning the installation of your system.

The use and application of the information contained herein require expertise in the design and programming of automated control systems. Only you, the user, machine builder or integrator, can be aware of all the conditions and factors present during installation and setup, operation, and maintenance of the machine or process, and can therefore determine the automation and associated equipment and the related safeties and interlocks which can be effectively and properly used. When selecting automation and control equipment, and any other related equipment or software, for a particular application, you must also consider any applicable local, regional or national standards and/or regulations.

Pay particular attention in conforming to any safety information, different electrical requirements, and normative standards that would apply to your machine or process in the use of this equipment.

Disconnecting Power

All options and modules should be assembled and installed before installing the control system on a mounting rail, onto a mounting plate or in a panel. Remove the control system from its mounting rail, mounting plate or panel before disassembling the equipment.

⚠️⚠️ DANGER
HAZARD OF ELECTRIC SHOCK, EXPLOSION OR ARC FLASH
<ul style="list-style-type: none"> • Disconnect all power from all equipment including connected devices prior to removing any covers or doors, or installing or removing any accessories, hardware, cables, or wires except under the specific conditions specified in the appropriate hardware guide for this equipment. • Always use a properly rated voltage sensing device to confirm the power is off where and when indicated. • Replace and secure all covers, accessories, hardware, cables, and wires and confirm that a proper ground connection exists before applying power to the unit. • Use only the specified voltage when operating this equipment and any associated products.
Failure to follow these instructions will result in death or serious injury.

Programming Considerations

⚠️ WARNING
UNINTENDED EQUIPMENT OPERATION
<ul style="list-style-type: none"> • Only use software approved by Schneider Electric for use with this equipment. • Update your application program every time you change the physical hardware configuration.
Failure to follow these instructions can result in death, serious injury, or equipment damage.

Operating Environment

In addition to the **Environmental Characteristics**, refer to **Product Related Information** in the beginning of the present document for important information regarding installation in hazardous locations for this specific equipment.

⚠ WARNING

UNINTENDED EQUIPMENT OPERATION

Install and operate this equipment according to the conditions described in the Environmental Characteristics.

Failure to follow these instructions can result in death, serious injury, or equipment damage.

Installation Considerations

⚠ WARNING

UNINTENDED EQUIPMENT OPERATION

- Use appropriate safety interlocks where personnel and/or equipment hazards exist.
- Install and operate this equipment in an enclosure appropriately rated for its intended environment and secured by a keyed or tooled locking mechanism.
- Use the sensor and actuator power supplies only for supplying power to the sensors or actuators connected to the module.
- Power line and output circuits must be wired and fused in compliance with local and national regulatory requirements for the rated current and voltage of the particular equipment.
- Do not use this equipment in safety-critical machine functions unless the equipment is otherwise designated as functional safety equipment and conforming to applicable regulations and standards.
- Do not disassemble, repair, or modify this equipment.
- Do not connect any wiring to reserved, unused connections, or to connections designated as No Connection (N.C.).

Failure to follow these instructions can result in death, serious injury, or equipment damage.

NOTE: JDYX2 or JDYX8 fuse types are cULus-recognized.

Installation Guidelines

Introduction

The TM3 bus coupler is connected to a controller using a fieldbus communication cable.

The TM3 bus coupler can be installed on a top hat section rail (DIN rail).

Correct Mounting Position

Whenever possible, the TM3 bus coupler should be mounted horizontally on a vertical plane as shown in the illustrations below:

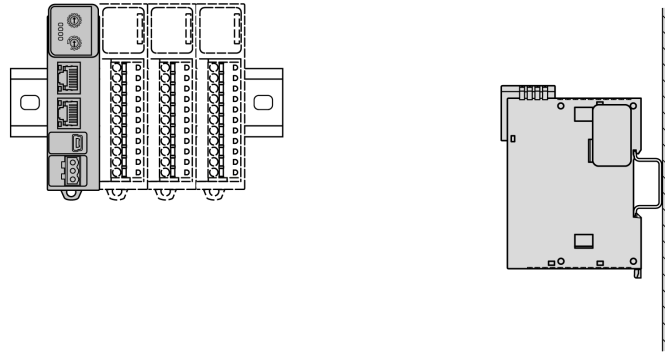

Acceptable Mounting Position

Whenever possible, the TM3 bus coupler can also be mounted vertically with a temperature derating on a vertical plane as shown below:

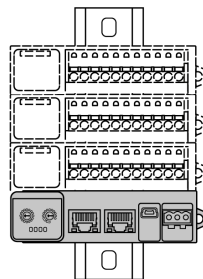

NOTE: Expansion modules must be mounted above the TM3 bus coupler.

Incorrect Mounting Position

The TM3 bus coupler should only be positioned as shown in [Correct Mounting Position](#), page 33. The following illustrations show the incorrect mounting positions:

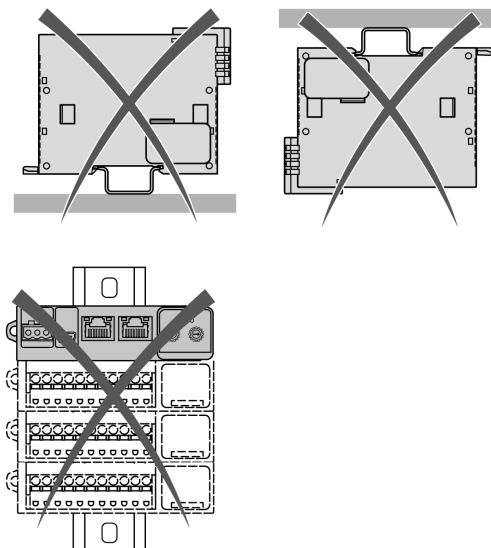

Minimum Clearances

⚠ WARNING
<p>UNINTENDED EQUIPMENT OPERATION</p> <ul style="list-style-type: none"> Place devices dissipating the most heat at the top of the cabinet and ensure adequate ventilation. Avoid placing this equipment next to or above devices that might cause overheating. Install the equipment in a location providing the minimum clearances from all adjacent structures and equipment as directed in this document. Install all equipment in accordance with the specifications in the related documentation. <p>Failure to follow these instructions can result in death, serious injury, or equipment damage.</p>

The TM3 bus coupler has been designed as an IP20 product and must be installed in an enclosure. Clearances must be respected when installing the product.

There are 3 types of clearances between:

- The TM3 bus coupler and all sides of the cabinet (including the panel door).
- The TM3 bus coupler terminal blocks and the wiring ducts. This distance reduces electromagnetic interference between the controller and the wiring ducts.
- The TM3 bus coupler and other heat generating devices installed in the same cabinet.

The following illustration shows the minimum clearances that apply to all TM3 bus coupler references:

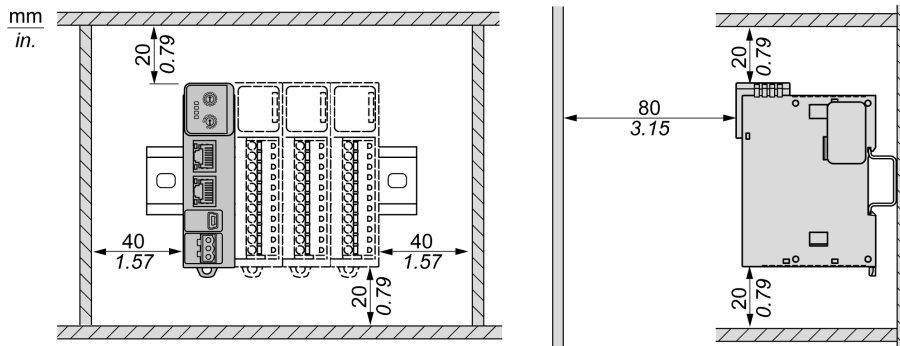

Top Hat Section Rail (DIN rail)

Dimensions of Top Hat Section Rail DIN Rail

You can mount the controller or receiver and their expansions on a 35 mm (1.38 in.) top hat section rail (DIN rail). The DIN rail can be attached to a smooth mounting surface or suspended from an EIA rack or mounted in a NEMA cabinet.

Symmetric Top Hat Section Rails (DIN Rail)

The following illustration and table indicate the references of the top hat section rails (DIN rail) for the wall-mounting range:

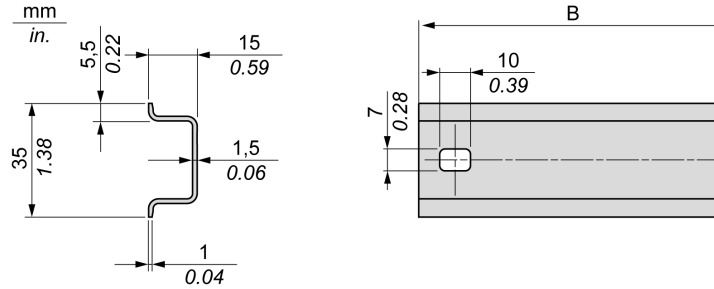

Reference	Type	Perforated	Rail Length (B)
NSYS DR50A	A	At each end	450 mm (17.71 in.)
NSYS DR60A	A	At each end	550 mm (21.65 in.)
NSYS DR80A	A	At each end	750 mm (29.52 in.)
NSYS DR100A	A	At each end	950 mm (37.40 in.)

The following illustration and table indicate the references of the symmetric top hat section rails (DIN rail) of 2000 mm (78.74 in.):

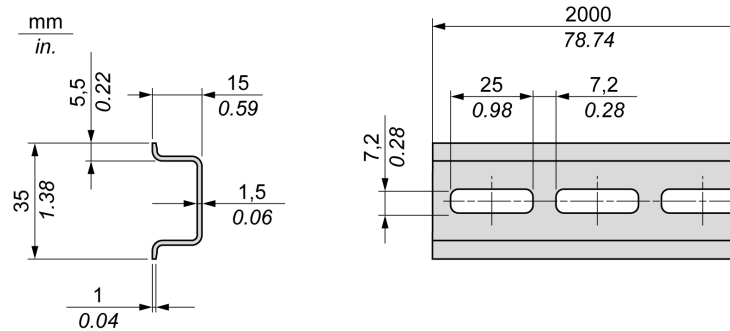

Reference	Type	Perforated	Rail Length
NSYS DR200	A	No	2000 mm (78.74 in.)
NSYS DR200D	A	Yes	

Double-Profile Top Hat Section Rails (DIN rail)

The following illustration and table indicate the references of the double-profile top hat section rails (DIN rail) of 2000 mm (78.74 in.):

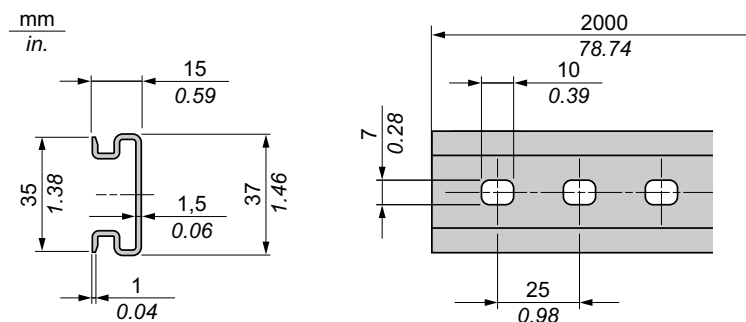

Reference	Type	Perforated	Rail Length
NSYDPR200	–	No	2000 mm (78.74 in.)
NSYDPR200D	–	Yes	

Assembling a Module to a Modicon TM3 Bus Coupler

Introduction

This section describes how to assemble an expansion module to a TM3 bus coupler.

⚡⚠ DANGER

HAZARD OF ELECTRIC SHOCK, EXPLOSION OR ARC FLASH

- Disconnect all power from all equipment including connected devices prior to removing any covers or doors, or installing or removing any accessories, hardware, cables, or wires except under the specific conditions specified in the appropriate hardware guide for this equipment.
- Always use a properly rated voltage sensing device to confirm the power is off where and when indicated.
- Replace and secure all covers, accessories, hardware, cables, and wires and confirm that a proper ground connection exists before applying power to the unit.
- Use only the specified voltage when operating this equipment and any associated products.

Failure to follow these instructions will result in death or serious injury.

After connecting new modules to the TM3 bus coupler, update your application program before placing the system back in service. If you do not update your application program to reflect the addition of new modules, I/O located on the expansion bus may no longer operate correctly.

⚠ WARNING

UNINTENDED EQUIPMENT OPERATION

- Only use software approved by Schneider Electric for use with this equipment.
- Update your application program every time you change the physical hardware configuration.

Failure to follow these instructions can result in death, serious injury, or equipment damage.

Assembling a Module to a Modicon TM3 Bus Coupler

The following procedure shows how to assemble a TM3 bus coupler and a module:

Step	Action
1	Remove all power and dismount any existing I/O assembly from its DIN mounting.
2	Remove the expansion connector sticker from the TM3 bus coupler.
3	Verify that the mounting clip on the new module is in the upper position.
4	Align the internal bus connector on the left side of the module with the internal bus connector on the right side of the TM3 bus coupler.
5	Press the new module towards the TM3 bus coupler until it is securely in place.
6	Push down the mounting clip on the top of the new module to lock it to the TM3 bus coupler.

Disassembling a Module from a Modicon TM3 Bus Coupler

Introduction

This section describes how to disassemble an expansion module from a TM3 bus coupler.

⚠️ DANGER

HAZARD OF ELECTRIC SHOCK, EXPLOSION OR ARC FLASH

- Disconnect all power from all equipment including connected devices prior to removing any covers or doors, or installing or removing any accessories, hardware, cables, or wires except under the specific conditions specified in the appropriate hardware guide for this equipment.
- Always use a properly rated voltage sensing device to confirm the power is off where and when indicated.
- Replace and secure all covers, accessories, hardware, cables, and wires and confirm that a proper ground connection exists before applying power to the unit.
- Use only the specified voltage when operating this equipment and any associated products.

Failure to follow these instructions will result in death or serious injury.

Disassembling a Module from a Modicon TM3 Bus Coupler

The following procedure describes how to disassemble a module from a TM3 bus coupler:

Step	Action
1	Remove all power from the control system.
2	Dismount the assembled TM3 bus coupler and modules from the mounting rail.
3	Push up the mounting clip from the bottom of the module to disengage it from the TM3 bus coupler.
4	Pull apart module from the TM3 bus coupler.

Direct Mounting on a Panel Surface

Overview

This section shows how to install TM3 bus coupler using the Panel Mounting Kit. This section also provides mounting hole layout.

Installing the Panel Mounting Kit

The following procedure shows how to install a mounting strip:

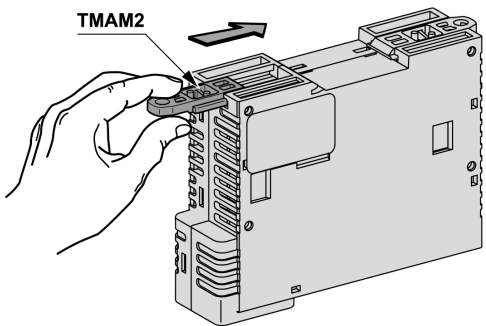
Step	Action
1	<p>Insert the mounting strip TMAM2 into the slot at the top of the module.</p> 

Mounting Hole Layout

The following diagram shows the mounting holes for TM3 bus coupler:

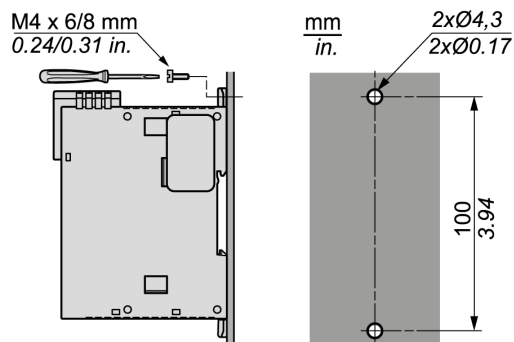

TM3 Electrical Requirements

Wiring Best Practices

Overview

This section describes the wiring guidelines and associated best practices to be respected when using the system.

⚠️ DANGER

HAZARD OF ELECTRIC SHOCK, EXPLOSION OR ARC FLASH

- Disconnect all power from all equipment including connected devices prior to removing any covers or doors, or installing or removing any accessories, hardware, cables, or wires except under the specific conditions specified in the appropriate hardware guide for this equipment.
- Always use a properly rated voltage sensing device to confirm the power is off where and when indicated.
- Replace and secure all covers, accessories, hardware, cables, and wires and confirm that a proper ground connection exists before applying power to the unit.
- Use only the specified voltage when operating this equipment and any associated products.

Failure to follow these instructions will result in death or serious injury.

⚠️ WARNING

LOSS OF CONTROL

- Perform a Failure Mode and Effects Analysis (FMEA), or equivalent risk analysis, of your application, and apply preventive and detective controls before implementation.
- Provide a fallback state for undesired control events or sequences.
- Provide separate or redundant control paths wherever required.
- Supply appropriate parameters, particularly for limits.
- Review the implications of transmission delays and take actions to mitigate them.
- Review the implications of communication link interruptions and take actions to mitigate them.
- Provide independent paths for control functions (for example, emergency stop, over-limit conditions, and error conditions) according to your risk assessment, and applicable codes and regulations.
- Apply local accident prevention and safety regulations and guidelines.¹
- Test each implementation of a system for proper operation before placing it into service.

Failure to follow these instructions can result in death, serious injury, or equipment damage.

¹ For additional information, refer to NEMA ICS 1.1 (latest edition), *Safety Guidelines for the Application, Installation, and Maintenance of Solid State Control* and to NEMA ICS 7.1 (latest edition), *Safety Standards for Construction and Guide for Selection, Installation and Operation of Adjustable-Speed Drive Systems* or their equivalent governing your particular location.

Wiring Guidelines

The following rules must be applied when wiring a system:

- I/O and communication wiring must be kept separate from the power wiring. Route these 2 types of wiring in separate cable ducting.
- Verify that the operating conditions and environment are within the specification values.
- Use proper wire sizes to meet voltage and current requirements.
- Use copper conductors.
- Use twisted-pair, shielded cables for analog, and/or fast I/O.
- Use twisted-pair, shielded cables for networks, and field bus.

⚠ WARNING

UNINTENDED EQUIPMENT OPERATION

- Use shielded cables for all fast I/O, analog I/O, and communication signals.
- Ground cable shields for all fast I/O, analog I/O, and communication signals at a single point¹.
- Route communications and I/O cables separately from power cables.

Failure to follow these instructions can result in death, serious injury, or equipment damage.

¹Multipoint grounding is permissible (and in some cases inevitable) if connections are made to an equipotential ground plane dimensioned to help avoid cable shield damage in the event of power system short-circuit currents.









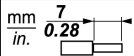

NOTE: Surface temperatures may exceed 60 °C (140 °F).



To conform to IEC 61010 standards, route primary wiring (wires connected to power mains) separately and apart from secondary wiring (extra low voltage wiring coming from intervening power sources). If that is not possible, double insulation is required such as conduit or cable gains.

All connectors must be connected to Protective Extra Low Voltage (PELV) according to UL 61010-2-201 or IEC 60950 or Class 2 of NEC.

Rules for Removable Screw Terminal Block

The following tables show the cable types and wire sizes for a **5.08 pitch** removable screw terminal block (I/Os and power supply):

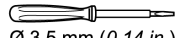
									
mm ²	0.2...2.5	0.2...2.5	0.25...2.5	0.25...2.5	2 x 0.2...1	2 x 0.2...1.5	2 x 0.25...1	2 x 0.5...1.5	
AWG	24...14	24...14	22...14	22...14	2 x 24...18	2 x 24...16	2 x 22...18	2 x 20...16	

		N•m	0.5...0.6
Ø 3,5 mm (0.14 in.)		lb-in	4.42...5.31

The use of 75 °C (167 °F) wires with copper conductors is required.

⚠ DANGER

FIRE HAZARD

Use only the correct wire sizes for the maximum current capacity of the power supplies.

Failure to follow these instructions will result in death or serious injury.

Protecting Outputs from Inductive Load Damage

Depending on the load, a protection circuit may be needed for the outputs on the controllers and certain modules. Inductive loads using DC voltages may create voltage reflections resulting in overshoot that will damage or shorten the life of output devices.

⚠ CAUTION
OUTPUT CIRCUIT DAMAGE DUE TO INDUCTIVE LOADS
Use an appropriate external protective circuit or device to reduce the risk of inductive direct current load damage.
Failure to follow these instructions can result in injury or equipment damage.

If your controller or module contains relay outputs, these types of outputs can support up to 240 Vac. Inductive damage to these types of outputs can result in welded contacts and loss of control. Each inductive load must include a protection device such as a peak limiter, RC circuit or flyback diode. Capacitive loads are not supported by these relays.

⚠ WARNING
RELAY OUTPUTS WELDED CLOSED
<ul style="list-style-type: none"> • Always protect relay outputs from inductive alternating current load damage using an appropriate external protective circuit or device. • Do not connect relay outputs to capacitive loads.
Failure to follow these instructions can result in death, serious injury, or equipment damage.

AC-driven contactor coils are, under certain circumstances, inductive loads that generate pronounced high-frequency interference and electrical transients when the contactor coil is de-energized. This interference may cause the logic controller to detect an I/O bus error.

⚠ WARNING
CONSEQUENTIAL LOSS OF CONTROL
Install an RC surge suppressor or similar means, such as an interposing relay, on each TM3 expansion module relay output when connecting to AC-driven contactors or other forms of inductive loads.
Failure to follow these instructions can result in death, serious injury, or equipment damage.

Protective circuit A: this protection circuit can be used for both AC and DC load power circuits.

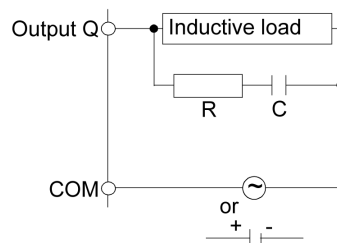

C Value from 0.1 to 1 μ F

R Resistor of approximately the same resistance value as the load

Protective circuit B: this protection circuit can be used for DC load power circuits.

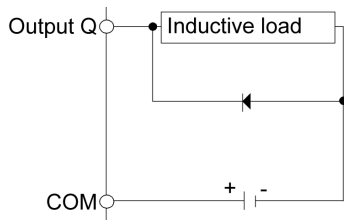

Use a diode with the following ratings:

- Reverse withstand voltage: power voltage of the load circuit x 10.
- Forward current: more than the load current.

Protective circuit C: this protection circuit can be used for both AC and DC load power circuits.

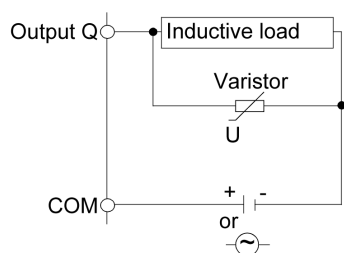

In applications where the inductive load is switched on and off frequently and/or rapidly, ensure that the continuous energy rating (J) of the varistor exceeds the peak load energy by 20 % or more.

DC Power Supply Characteristics and Wiring

Overview

This section provides the characteristics and the wiring diagrams of the DC power supply.

DC Power Supply Voltage Range

⚠ DANGER

FIRE HAZARD

Use only the correct wire sizes for the maximum current capacity of the power supplies.

Failure to follow these instructions will result in death or serious injury.

⚠ WARNING

UNINTENDED EQUIPMENT OPERATION

Do not exceed any of the rated values specified in the environmental and electrical characteristics tables.

Failure to follow these instructions can result in death, serious injury, or equipment damage.

DC Power Supply Requirements

The TM3 bus coupler and the associated expansion modules require power supplies with a nominal voltage of 24 Vdc. The 24 Vdc power supplies must be rated Protective Extra Low Voltage (PELV) according to UL 61010-2-201 or IEC 60950 or Class 2 of NEC. These power supplies are isolated between the electrical input and output circuits of the power supply.

⚠ WARNING
POTENTIAL OF OVERHEATING AND FIRE
<ul style="list-style-type: none"> Do not connect the equipment directly to line voltage. Use only isolating PELV power supplies and circuits to supply power to the equipment¹.
Failure to follow these instructions can result in death, serious injury, or equipment damage.

¹ For compliance to UL (Underwriters Laboratories) requirements, the power supply must also conform to the various criteria of NEC Class 2, and be inherently current limited to a maximum power output availability of less than 100 VA (approximately 4 A at nominal voltage), or not inherently limited but with an additional protection device such as a circuit breaker or fuse meeting the requirements of clause 9.4 Limited-energy circuit of UL 61010-1. In all cases, the current limit should never exceed that of the electric characteristics and wiring diagrams for the equipment described in the present documentation. In all cases, the power supply must be grounded, and you must separate Class 2 circuits from other circuits. If the indicated rating of the electrical characteristics or wiring diagrams are greater than the specified current limit, multiple Class 2 power supplies may be used.

Modicon TM3 Bus Coupler DC Characteristics

The following table shows the DC power supply characteristics required for the TM3 bus coupler:

Characteristic		Value
Rated voltage		24 Vdc
Power supply voltage range		20.4...28.8 Vdc
Power interruption time		1 ms at 24 Vdc
Maximum inrush current		50 A
Input current		Maximum 800 mA
Power consumption		14.4 W Maximum 19.2 W
Isolation	between DC power supply and internal bus	Not isolated
	between DC power supply and grounding	Not isolated

Power interruption

The TM3 bus coupler must be supplied by an external 24 V power supply equipment. During power interruptions, the TM3 bus coupler, associated to the suitable power supply, is able to continue normal operation for a minimum of 10 ms as specified by IEC standards.

When planning the management of the power supplied to the controller, you must consider the power interruption duration due to the fast cycle time of the controller.

There could potentially be many scans of the logic and consequential updates to the I/O image table during the power interruption, while there is no external power

supplied to the inputs, the outputs or both depending on the power system architecture and power interruption circumstances.

⚠ WARNING
<p>UNINTENDED EQUIPMENT OPERATION</p> <ul style="list-style-type: none"> • Individually monitor each source of power used in the controller system including input power supplies, output power supplies and the power supply to the controller to allow appropriate system shutdown during power system interruptions. • The inputs monitoring each of the power supply sources must be unfiltered inputs. <p>Failure to follow these instructions can result in death, serious injury, or equipment damage.</p>

DC Power Supply Wiring Diagram

The following illustration shows the power supply terminal block:

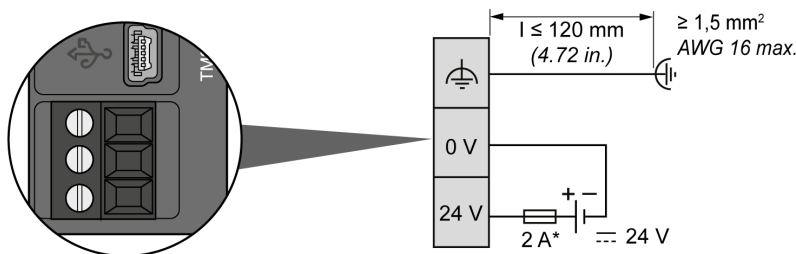

* Type T fuse

For more information, refer to the 5.08 pitch Rules for Removable Screw Terminal block, page 40.

Grounding the TM3 System

Overview

Due to the effects of electromagnetic interference, cables carrying fast I/O, analog I/O, and the fieldbus communication signals must be shielded.

⚠ WARNING
<p>UNINTENDED EQUIPMENT OPERATION</p> <ul style="list-style-type: none"> • Use shielded cables for all fast I/O, analog I/O, and communication signals. • Ground cable shields for all fast I/O, analog I/O, and communication signals at a single point¹. • Route communications and I/O cables separately from power cables. <p>Failure to follow these instructions can result in death, serious injury, or equipment damage.</p>

¹Multipoint grounding is permissible (and in some cases inevitable) if connections are made to an equipotential ground plane dimensioned to help avoid cable shield damage in the event of power system short-circuit currents.

The use of shielded cables requires compliance with the following wiring rules:

- For protective earth ground connections (PE), metal conduit or ducting can be used for part of the shielding length, provided there is no break in the continuity of the ground connections. For functional earth ground (FE), the shielding is intended to attenuate electromagnetic interference and the shielding must be continuous for the length of the cable. If the purpose is both functional and protective, as is often the case for communication cables, the cable must have continuous shielding.
- Wherever possible, keep cables carrying one type of signal separate from the cables carrying other types of signals or power.

Protective Earth Ground (PE) on the Backplane

The protective earth ground (PE) is connected to the conductive backplane by a heavy-duty wire, usually a braided copper cable with the maximum allowable cable section.

Functional Earth Ground (FE) on the DIN Rail

The DIN Rail for your system is common with the functional earth ground (FE) plane and must be mounted on a conductive backplane.

⚠ WARNING
UNINTENDED EQUIPMENT OPERATION
Connect the DIN rail to the functional earth ground (FE) of your installation.
Failure to follow these instructions can result in death, serious injury, or equipment damage.

Shielded Cables Connections

Cables carrying fast I/O, analog I/O, and the fieldbus communication signals must be shielded. The shielding must be securely connected to ground. Fast I/O and analog I/O shields may be connected either to the functional earth ground (FE) or to the protective earth ground (PE) of your TM3 expansion module. The fieldbus communication cable shields must be connected to the protective earth ground (PE) with a connecting clamp secured to the conductive backplane of your installation.

⚠ WARNING
ACCIDENTAL DISCONNECTION FROM PROTECTIVE GROUND (PE)
<ul style="list-style-type: none"> • Do not use the Grounding Bar to provide a protective earth ground (PE). • Use the Grounding Bar only to provide a functional earth ground (FE).
Failure to follow these instructions can result in death, serious injury, or equipment damage.

TM3 Ethernet Bus Coupler

TM3 Ethernet Bus Coupler Presentation

Overview

The TM3 bus coupler is a device designed to manage EtherNet/IP or Modbus TCP communication when using TM2/TM3 expansion modules in a distributed architecture.

The main elements of the TM3 bus coupler are:

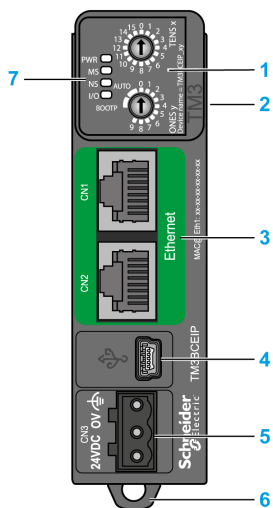

- 1 Rotary switches
- 2 Expansion connector for TM2/TM3 expansion modules
- 3 Two (2) isolated switched Ethernet ports
- 4 USB mini-B configuration port
- 5 24 Vdc power supply
- 6 Clip-on lock for 35 mm (1.38 in.) top hat section rail (DIN rail)
- 7 Status LEDs

Main Characteristics

Characteristic	Value
Rated power supply	24 Vdc
Weight	100 g (3.53 oz)
Rotary switch	2
Ethernet	2 (isolated switched Ethernet ports: 10 Mbps / 100 Mbps)
Power supply connection type	Removable screw terminal block

Status LEDs

The following graphic shows the LEDs of TM3 bus coupler:



The following table describes the status LEDs:

LED	Color	Status	Description
PWR	Green	On	Power is applied.
		Off	Power is removed. All LED indicators are off.
MS	Green/Red	Flashing	Device is performing a self-test.
		Solid	Device is running.
	Flashing	Device detected an invalid configuration or is not configured.	
	Red	Solid	Device detected an error that is, under most circumstances, unrecoverable.
		Flashing	Device detected an error that is, under most circumstances, recoverable. For example: <ul style="list-style-type: none"> • Rotary switch position changed during operational mode. • Error detected during firmware update.
	NS	Green/Red	Off
Flashing			Device is performing a self-test.
Green		Solid	At least one CIP connection is established, and an exclusive owner connection has not timed out.
		Flashing	The IP address is configured, but CIP connections are not established and an exclusive owner connection has not timed out.
Red		Solid	Device detected that the IP address is already in use.
		Flashing	An IP address is configured, and an exclusive owner connection for which this device is the target has timed out.
I/O	Green	Solid	Device is communicating with the expansion modules.
		Flashing	The physical configuration matches the software configuration, but no communication exists between the bus coupler and the expansion modules.
	Red	Solid	The physical configuration is inconsistent with the software configuration.
		Flashing	At least one TM2 or TM3 expansion module did not respond to the bus coupler for three consecutive cycles.

NOTE: With the exception of the **PWR** LED, each LED is ON for a few seconds, then OFF during the boot sequence. The LED behavior rules apply when the boot is completed successfully.

TM3 Ethernet Bus Coupler Characteristics

Introduction

This section provides a general description of the characteristics of the TM3 Ethernet bus coupler.

▲ WARNING
UNINTENDED EQUIPMENT OPERATION
Do not exceed any of the rated values specified in the environmental and electrical characteristics tables.
Failure to follow these instructions can result in death, serious injury, or equipment damage.

Dimensions

The following graphic shows the external dimensions for the Modicon TM3 Bus Coupler:

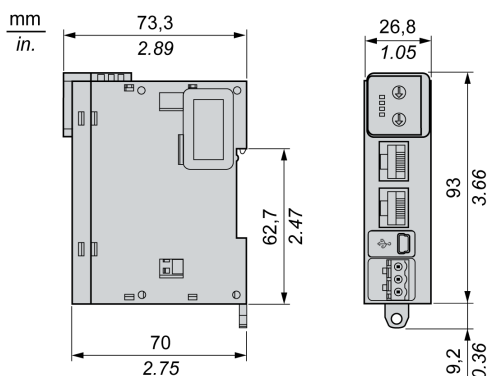

General Characteristics

The following table shows the characteristics of TM3 Ethernet Bus Coupler:

Characteristics	Value
Connector insertion/removal durability	Over 100 times
Supplied power available for connected inputs and outputs modules	600 mA maximum
Current draw on 5 Vdc and 24 Vdc internal bus	

Rotary Switch

Overview

The two rotary switches located on the front panel of the TM3 Ethernet Bus Coupler are used to set an IP address.

The default values on the rotary switches are:

- **0** for **TENSx**
- **AUTO** for **ONESy**

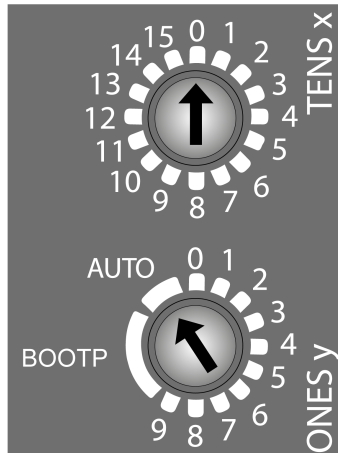

NOTE: You can also set the IP address using the web server. The web server configured IP address is only taken into account when the rotary switch is in the **AUTO** position. If you use EcoStruxure Machine Expert - Basic, refer to the Modicon TM3 Bus Coupler (EcoStruxure Machine Expert - Basic) - Programming Guide. If you use EcoStruxure Machine Expert, refer to the Modicon TM3 Bus Coupler - Programming Guide.

Setting an IP Address

Set the rotary switches before:

- Applying power to the module.
- Downloading the application.

NOTE: Any modification of the rotary switch position is taken into account after power up.

This table describes the configuration of the rotary switches:

Position of the rotary switches		Description
Tens	Ones	
0...15	0...9	Allows you to configure the device name. Use both switches to select a numeric value from 0...159. For example, if TENS x = 08 and ONES y = 6, the device name is TM3BCEIP_086. NOTE: Device names TM3BCEIP_091...TM3BCEIP_159 are reserved.
Any	AUTO	The default IP address (10.10.x.x) is used. The last two fields in the default IP address are composed of the last two hexadecimal bytes of the MAC address of the port. You can change the network configuration with the embedded web server. NOTE: A MAC address is always written in hexadecimal format and an IP address in decimal format. Convert the MAC address to decimal format. For example, if the MAC address is 00.80.F4.01.80.F2, the default IP address is 10.10.128.242. If you use EcoStruxure Machine Expert - Basic, refer to the Modicon TM3 Bus Coupler (EcoStruxure Machine Expert - Basic) - Programming Guide. If you use EcoStruxure Machine Expert, refer to the Modicon TM3 Bus Coupler - Programming Guide.
Any	BOOTP	Uses the MAC address to request the IP parameters.

Carefully manage the IP addresses because each device on the network requires a unique address. Having multiple devices with the same IP address can cause unintended operation of your network and associated equipment.

⚠ WARNING
<p>UNINTENDED EQUIPMENT OPERATION</p> <ul style="list-style-type: none"> • Verify that there is only one master controller configured on the network or remote link. • Verify that all devices have unique addresses. • Obtain your IP address from your system administrator. • Confirm that the IP address of the device is unique before placing the system into service. • Do not assign the same IP address to any other equipment on the network. • Update the IP address after cloning any application that includes Ethernet communications to a unique address. <p>Failure to follow these instructions can result in death, serious injury, or equipment damage.</p>

NOTE: This device comes pre configured with an IP address of 10.10.xxx.xxx. Change this default address before using the device on the network.

It is good practice to ensure that your system administrator maintains a record of all assigned IP addresses on the network and subnetwork, and to inform the system administrator of all configuration changes performed.

Applying the IP Address

The device reads the position of the rotary switches at power up.

If your device does not communicate, verify that the position of the rotary switches is correct. If you change the position of the rotary switches when in operation mode, the **MS** flashes red. You must do a power cycle to apply the new address.

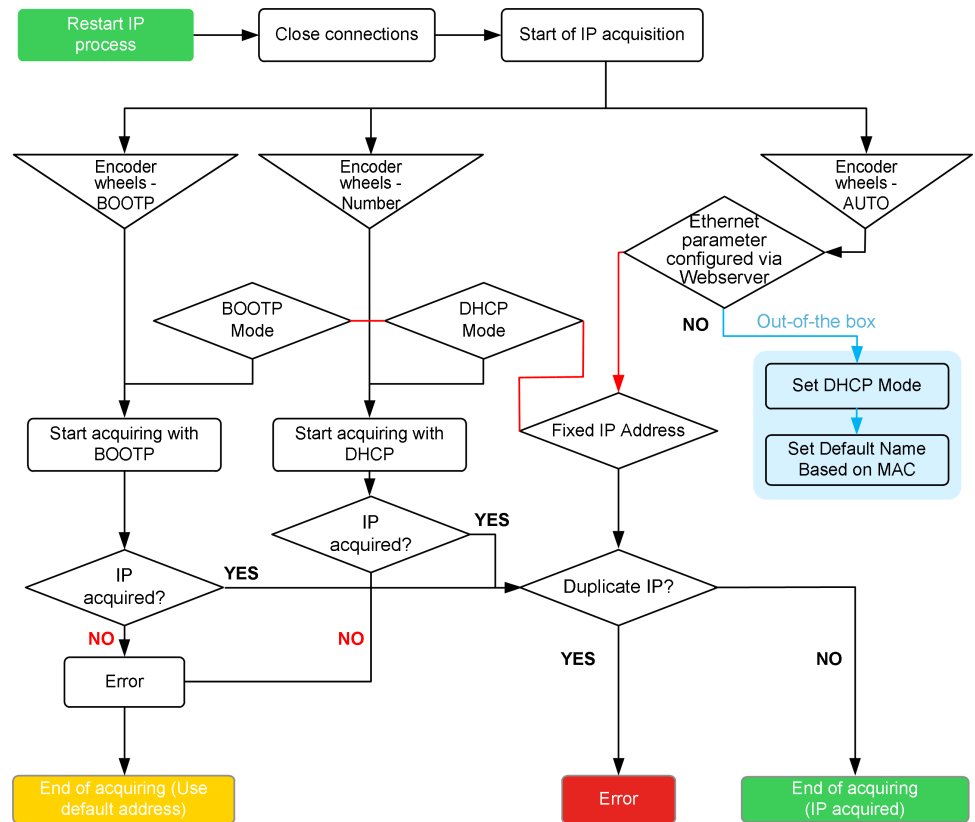

Ethernet Port

Overview

The TM3BCEIP is equipped with two isolated switched Ethernet ports (**CN1**, **CN2**) enabling easy daisy-chain configuration.

Characteristics

This table describes the Ethernet characteristics:

Characteristic	Description
Function	Modbus TCP, EtherNet/IP
Connector type	RJ45
Auto negotiation	From 10 Mbps half duplex to 100 Mbps full duplex
Cable type	Shielded
Automatic cross-over detection	Yes
Topology	Ring type

Pin Assignment

This graphic shows the RJ45 Ethernet connector pin assignment:

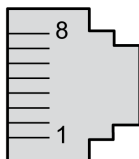

This table describes the RJ45 Ethernet connector pins:

Pin N°	Signal
1	TD+
2	TD-
3	RD+
4	-
5	-
6	RD-
7	-
8	-

NOTE: The TM3 Ethernet Bus Coupler supports the MDI/MDIX auto-crossover cable function. It is not necessary to use special Ethernet crossover cables to connect devices directly to this port (connections without an Ethernet hub or switch).

NOTE: Ethernet cable disconnection is detected every second. In case of disconnection of a short duration (< 1 second), the network status may not indicate the disconnection.

Status LEDs

This graphic shows RJ45 connectors status LEDs:

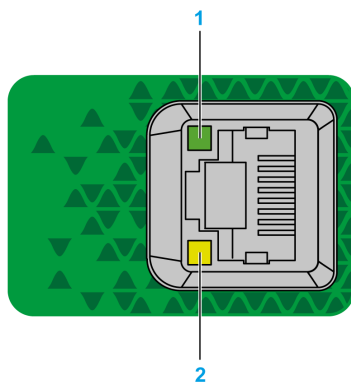

This table describes the Ethernet status LEDs:

Label	Description	LED		
		Color	Status	Description
1	Ethernet activity	Green	Off	No activity
			Flashing	Transmitting or receiving data
2	Ethernet link	Green/Orange	Off	No link
			Orange on	Link at 10 Mbit/s
			Green on	Link at 100 Mbit/s

Connecting the Modicon TM3 Bus Coupler to a PC

Overview

You can connect the TM3 bus coupler to a PC through the following ports:

- USB
- Ethernet

USB Mini-B Port Connection

The USB Mini-B port is dedicated for firmware update, configuration download and web server access.

Cable Reference	Details
BMXXCAUSBH018	Grounded and shielded, this USB cable is suitable for long duration connections.
TCSXCNAMUM3P	This USB cable is suitable for short duration connections such as quick updates or retrieving data values.

NOTE: You can only connect one TM3 bus coupler or any other device associated with EcoStruxure Machine Expert and its component to the PC at any one time.

Using a typical USB cable, this connection is suitable for short duration connections to perform maintenance and inspect data values. It is not suitable for long-term connections such as commissioning or monitoring without the use of specially adapted cables to help minimize electromagnetic interference.

⚠ WARNING

UNINTENDED EQUIPMENT OPERATION OR INOPERABLE EQUIPMENT

- You must use a shielded USB cable such as a BMX XCAUSBH0** secured to the functional ground (FE) of the system for any long-term connection.
- Do not connect more than one controller or bus coupler at a time using USB connections.
- Do not use the USB port(s), if so equipped, unless the location is known to be non-hazardous.

Failure to follow these instructions can result in death, serious injury, or equipment damage.

The communication cable should be connected to the PC first to minimize the possibility of electrostatic discharge affecting the TM3 bus coupler.

Grounded and shielded, this USB cable is suitable for long-term connections.

The following illustration shows the USB connection to a PC:

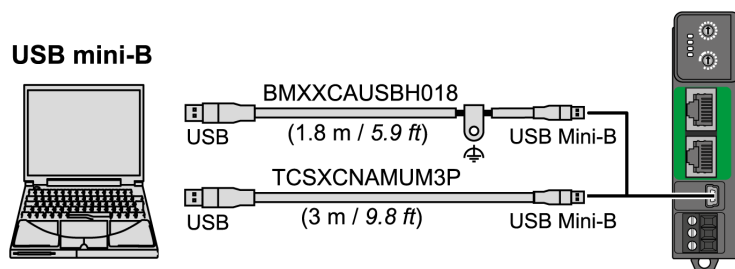

To connect the USB cable to your TM3 bus coupler, follow the steps below:

Step	Action
1	<p>1a. If making a long-term connection using the cable BMXXCAUSBH018, or other cable with a ground shield connection, be sure to securely connect the shield connector to the functional ground (FE) or protective ground (PE) of your system before connecting the cable to your controller and your PC.</p> <p>1b. If making a short-term connection using the cable TCSXCNAMUM3P or other non-grounded USB cable, proceed to step 2.</p>
2	Connect your USB cable to the PC.
3	Connect the Mini connector of your USB cable to the TM3 bus coupler USB connector.

Ethernet Port Connection

To connect the TM3 bus coupler to a PC using the Ethernet ports:

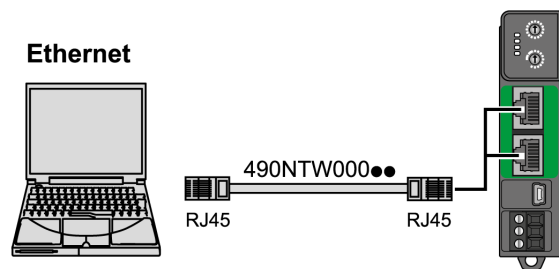

To connect the TM3 bus coupler to the PC, do the following:

Step	Action
1	Connect the Ethernet cable to the PC.
2	Connect the Ethernet cable to one of the Ethernet ports on the TM3 bus coupler.

TM3 Modbus Serial Line Bus Coupler

TM3 Modbus Serial Line Bus Coupler Presentation

Overview

The TM3 Modbus Serial Line bus coupler is a device designed to manage Serial Line communication when using TM2/TM3 expansion modules in a distributed architecture.

The main elements of the TM3 Modbus Serial Line bus coupler are:

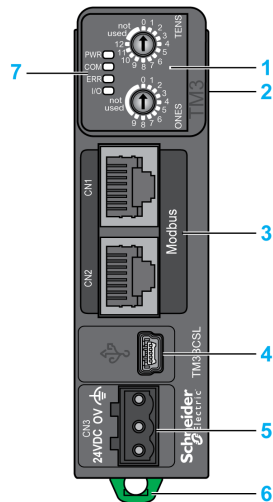

- 1 Rotary switches
- 2 Expansion connector for TM2/TM3 expansion modules
- 3 Two (2) isolated RJ45 (RS-485) ports (daisy-chained)
- 4 USB mini-B configuration port
- 5 24 Vdc power supply
- 6 Clip-on lock for 35 mm (1.38 in.) top hat section rail (DIN rail)
- 7 Status LEDs

Main Characteristics

Characteristic	Value
Rated power supply	24 Vdc
Weight	100 g (3.53 oz)
Rotary switch	2
Serial line	2 isolated RJ45 (RS-485) ports (daisy-chained)
Power supply connection type	Removable screw terminal block

Status LEDs

The following graphic shows the LEDs of TM3 Modbus Serial Line bus coupler:



The following table describes the status LEDs:

LED	Color	Status	Description
PWR	Green	On	Power is applied.
		Off	Power is removed. All LED indicators are off.
COM	Green	Flashing	Data sending and receiving.
		Off	No data exchanged.
	Red	Flashing	Device is receiving an incorrect data frame.
ERR	Red	Flashing	Device has detected an error that is, under most circumstances, recoverable. For example: <ul style="list-style-type: none"> Rotary switch position changed during operational mode. Return to the initial position to reset the LED behavior. Error detected during firmware update. Communication and configuration errors.
		Off	No error detected.
I/O	Green	Flashing	Device has received and applied the expansion modules configuration.
		Solid	Device is communicating with the expansion modules.
	Green Red	Flashing Solid	The physical configuration is inconsistent with the software configuration. No data exchange (status and I/O) is occurring.
	Green Red	Solid Solid	The physical configuration is inconsistent with the software configuration. I/O data is not applied.
	Green Red	Solid Flashing	At least one TM2 or TM3 expansion module did not respond to the bus coupler for 10 consecutive cycles.
	Off	Off	No configuration. Device is not communicating with the expansion modules.

NOTE: With the exception of the PWR LED, each LED is ON for a few seconds, then OFF during boot sequence. The LED behavior rules apply when the boot is completed successfully.

TM3 Modbus Serial Line Bus Coupler Characteristics

Introduction

This section provides a general description of the characteristics of the TM3 Modbus Serial Line bus coupler.

▲ WARNING
UNINTENDED EQUIPMENT OPERATION
Do not exceed any of the rated values specified in the environmental and electrical characteristics tables.
Failure to follow these instructions can result in death, serious injury, or equipment damage.

Dimensions

The following graphic shows the external dimensions for the TM3 Modbus Serial Line bus coupler:

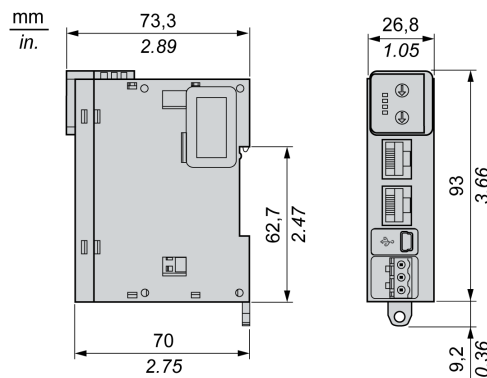

General Characteristics

The following table shows the characteristics of TM3 Modbus Serial Line bus coupler:

Characteristics	Value
Connector insertion/removal durability	Over 100 times
Supplied power available for connected inputs and outputs modules	600 mA maximum
Current draw on 5 Vdc and 24 Vdc internal bus	

Rotary Switch

Overview

The two rotary switches located on the front panel of the TM3 Modbus Serial Line bus coupler are used to set the serial line baud rate and to set the serial line address.

Default values on the rotary switches are:

- 0 for **TENS**
- 0 for **ONES**

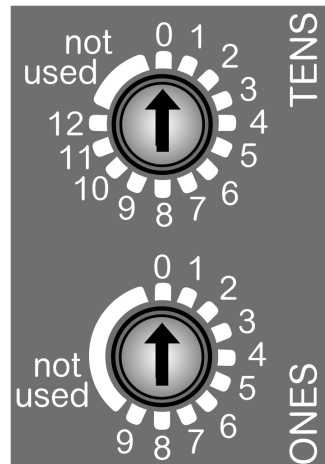

(TENS) Set the baud rate/represents the tens numbered 0 to 120.

(ONES) Authorize to set the baud rate when set to **not used** position/represents the numbers 0 to 9.

Setting the Baud rate

The TM3 Modbus Serial Line bus coupler detects a new baud rate selection by the rotary switches only during power up. The baud rate is written to non-volatile memory.

Set the **ONES** rotary switch to any of the unnumbered positions (**not used**) to set a particular baud rate with the **TENS** rotary switch.

NOTE: Any modification of the rotary switch position during operational mode is not taken into account. The **ERR** LED flashes red. See *status LEDs*, page 57 table.

NOTE: Baud rate can also be set and verified via the web server. If you use EcoStruxure Machine Expert - Basic, refer to the Modicon TM3 Bus Coupler (EcoStruxure Machine Expert - Basic) - Programming Guide. If you use EcoStruxure Machine Expert, refer to the Modicon TM3 Bus Coupler - Programming Guide.

To set the baud rate, follow the steps below:

Step	Action	Comment
1	Remove power to the bus coupler.	The bus coupler detects the changes only at the next power up cycle.
2	With a 2 mm or 2.5 mm slotted (flathead) screwdriver, set the ONES rotary switch to any of the unnumbered positions (not used). NOTE: Rotary switch is designed to be torqued normally by hand. Axial force must be inferior to 2 N.	Setting the rotary switch to any of these unnumbered positions prepares the bus coupler to accept a new baud rate.
3	With a 2 mm or 2.5 mm slotted (flathead) screwdriver, set the TENS rotary switch to the position that corresponds to your selected baud rate.	Use the baud rate selection table below to determine the position of the rotary switch.
4	Apply power to the bus coupler.	The bus coupler reads the rotary switch settings only during power up.
5	Wait for the COM and the ERR LEDs to flash 3 times, then remain solid.	The bus coupler has written the new baud rate setting to memory.
6	Remove power to the bus coupler and set the serial line address using the rotary switches, as described below in Setting the Serial Line address, page 61.	The baud rate has been established for the bus coupler. It must be followed by the address setting to operate.

Baud Rate Selection Table

The following table shows the rotary switch positions and the baud rate:

Position TENS rotary switch	Baud rate
0	19200 bps (default)
1	1200 bps
2	2400 bps
3	4800 bps
4	9600 bps
5	19200 bps
6	38400 bps
7	57600 bps
8	115200 bps
9...12	Not used

NOTE: Setting the **TENS** rotary switch between 9 and 12 and unnumbered part generates an error detected at the next power up.

Baud Rate Setting Example

The following figure shows an example when the serial line baud rate is configured to 19200 bps.

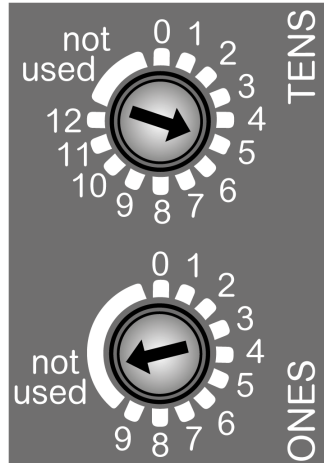

(TENS) Set to 5 to configure the serial line baud rate to 19200 bps.

(ONES) Set to the **not used** position to authorize the baud rate setting.

Setting the Serial Line Address

The TM3 Modbus Serial Line bus coupler address (from 1 to 127, decimal) is configured using the two serial line address settings rotary switches.

⚠ WARNING

UNINTENDED EQUIPMENT OPERATION

Do not use an address outside of the specified range (from 1 to 127).

Failure to follow these instructions can result in death, serious injury, or equipment damage.

To reset the bus coupler, remove power and provide a correct address before reapplying power to the bus coupler.

Set the serial line address using the **TENS** rotary switch to represent the hundreds and tens digits and the **ONES** rotary switch to represent the units digits.

Carefully manage the addresses because each device on the network requires a unique address. Having multiple devices with the same address can cause unintended operation of your network and associated equipment.

⚠ WARNING

UNINTENDED EQUIPMENT OPERATION

- Do not connect the serial line cable and apply power to the TM3 Modbus Serial Line Bus Coupler on a serial line that is operational (other devices connected in an ongoing control scheme) unless you first set the appropriate, unique address for the Bus Coupler.
- Assure that unique Modbus addresses are assigned to the TM3 Modbus Serial Line Bus Coupler, and that those addresses are also unique from all other devices connected to the serial line.

Failure to follow these instructions can result in death, serious injury, or equipment damage.

Serial Line Address Setting Example

The following figure shows an example when the serial line address is set to 115:

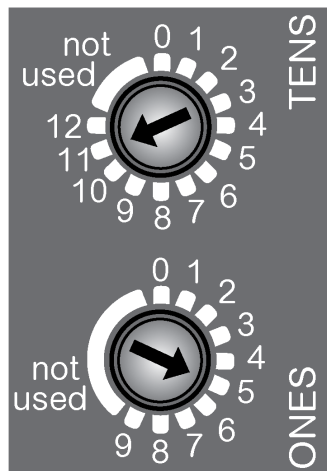

(TENS) Represents the tens numbered 0 to 120, set to 110.

(ONES) Represents the numbers 0 to 9, set to 5.

Serial Line Port

Overview

The TM3 Modbus Serial Line bus coupler is equipped with two isolated RJ45 ports (**CN1**, **CN2**) enabling easy daisy-chain configuration, as shown in following graphic:

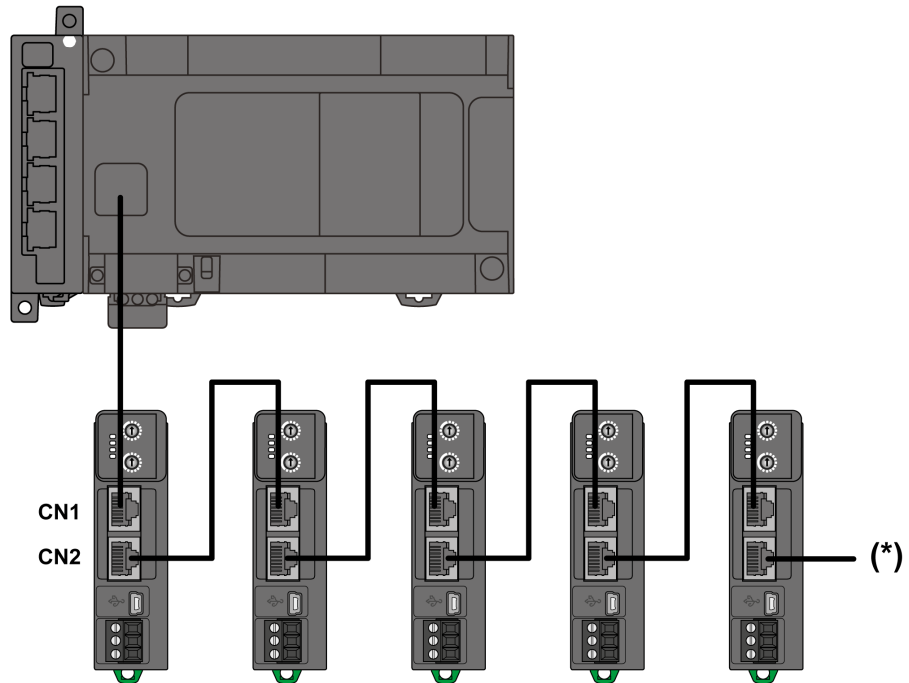

* You can connect a maximum of 32 Modbus devices. The last device must be terminated by terminating resistor.

Characteristics

This table describes the serial line characteristics:

Characteristic	Description
Function	Serial line, Modbus, TIA-485
Connector type	RJ45
Cable type	Shielded
Topology	Bus Type

Pin Assignment

This graphic shows the RJ45 (RS-485) connector pin assignment:

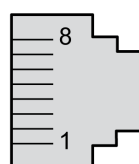

This table describes the RJ45 (RS-485) connector pins:

Pin N°	Signal	Description
1	N.C.	No Connection
2	N.C.	No Connection
3	N.C.	No Connection
4	D1	Transmit/receive data Low
5	D0	Transmit/receive data High
6	N.C.	No Connection
7	N.C.	No Connection
8	C	Common

⚠ WARNING
UNINTENDED EQUIPMENT OPERATION
Do not connect wires to unused terminals and/or terminals indicated as “No Connection (N.C.)”.
Failure to follow these instructions can result in death, serious injury, or equipment damage.

Connecting the TM3 Modbus Serial Line Bus Coupler to a PC

Overview

You can connect the TM3 Modbus Serial Line bus coupler to a PC through the USB port.

USB Mini-B Port Connection

The USB Mini-B port is dedicated for firmware update, configuration download and web server access.

Cable Reference	Details
BMXXCAUSBH018	Grounded and shielded, this USB cable is suitable for long duration connections.
TCSXCNAMUM3P	This USB cable is suitable for short duration connections such as quick updates or retrieving data values.

NOTE: You can only connect one TM3 bus coupler or any other device associated with EcoStruxure Machine Expert and its component to the PC at any one time.

Using a typical USB cable, this connection is suitable for short duration connections to perform maintenance and inspect data values. It is not suitable for long-term connections such as commissioning or monitoring without the use of specially adapted cables to help minimize electromagnetic interference.

⚠ WARNING

UNINTENDED EQUIPMENT OPERATION OR INOPERABLE EQUIPMENT

- You must use a shielded USB cable such as a BMX XCAUSBH0•• secured to the functional ground (FE) of the system for any long-term connection.
- Do not connect more than one controller or bus coupler at a time using USB connections.
- Do not use the USB port(s), if so equipped, unless the location is known to be non-hazardous.

Failure to follow these instructions can result in death, serious injury, or equipment damage.

The communication cable should be connected to the PC first to minimize the possibility of electrostatic discharge affecting the TM3 Modbus Serial Line bus coupler.

The following illustration shows the USB connection to a PC:

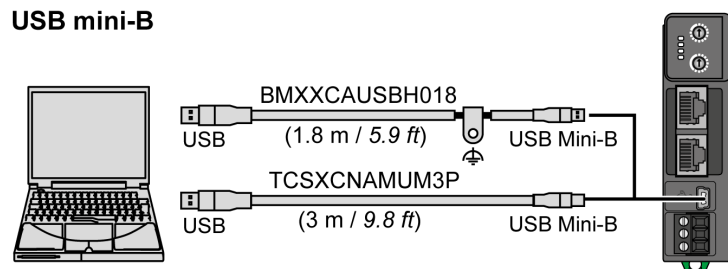

To connect the USB cable to your TM3 Modbus Serial Line bus coupler, follow the steps below:

Step	Action
1	1a. If making a long-term connection using the cable BMXXCAUSBH018, or other cable with a ground shield connection, be sure to securely connect the shield connector to the functional ground (FE) or protective ground (PE) of your system before connecting the cable to your controller and your PC. 1b. If making a short-term connection using the cable TCSXCNAMUM3P or other non-grounded USB cable, proceed to step 2.
2	Connect your USB cable to the PC.
3	Connect the Mini connector of your USB cable to the TM3 Modbus Serial Line bus coupler USB connector.

TM3 CANopen Bus Coupler

TM3 CANopen Bus Coupler Presentation

Overview

The TM3 CANopen bus coupler is a device designed to manage CANopen communication when using TM2/TM3 I/O expansion modules in a distributed architecture.

The main elements of the TM3 CANopen bus coupler are:

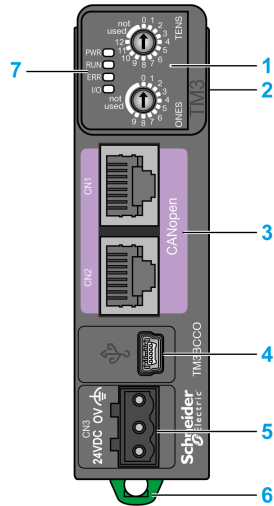

- 1 Rotary switches
- 2 Expansion connector for TM2/TM3 I/O expansion modules
- 3 Two (2) isolated RJ45 CANopen ports (daisy-chained)
- 4 USB mini-B configuration port
- 5 24 Vdc power supply
- 6 Clip-on lock for 35 mm (1.38 in.) top hat section rail (DIN rail)
- 7 Status LEDs

Main Characteristics

Characteristic	Value
Nominal supply voltage	24 Vdc
Weight	100 g (3.53 oz)
Rotary switch	2
CANopen port	2 isolated RJ45 ports for CANopen (daisy-chained).
Power supply connection type	Removable screw terminal block

Status LEDs

The following graphic shows the LEDs of TM3 CANopen bus coupler:



The following table describes the status LEDs:

LED	Color	Status	Description
PWR	Green	On	Power is applied.
		Off	Power is removed. All LED indicators are off.
RUN	Green	On	Device status is operational.
		Flickering	In conjunction with a flickering ERR LED, automatic search for the bus communication speed.
		Flashing	Device status is pre-operational.
		Single flash	Device status is stopped.
		Triple flash	Firmware upgrade.
ERR	Red	On	Bus off.
		Flickering	In conjunction with a flickering RUN LED, automatic search for the bus communication speed.
		Flashing	Invalid CANopen stack configuration.
		Single flash	An internal error counter in the CAN controller has reached or exceeded the error frame limit threshold (error frame).
		Double flash	Error control event detected. Detection of a guard event (NMT-Slave or NMT-master) or a heartbeat event (Heartbeat consumer).
		Triple flash	Synchronization error detected: message not received from sync producer within the defined period.
		Quadruple flash	Event-timer error detected: An expected PDO has not been received before the event-timer elapsed.
		Off	No error detected.
I/O	Green	Flashing	Device has received and applied the expansion modules configuration.
		On	Device is communicating with the expansion modules.
	Red	Single flash	Expansion module configuration transfer timeout.
	Green Red	Flashing	The physical configuration is inconsistent with the software configuration. No data exchange (status and I/O) is occurring.
		On	
	Green Red	On	The physical configuration is inconsistent with the software configuration. I/O data is not applied.
		On	
	Green Red	On	At least one TM2 or TM3 expansion module did not respond to the bus coupler for 10 consecutive cycles.
Flashing			
		Off	No configuration. Device is not communicating with the expansion modules.

This timing diagram shows the different LEDs flashing behaviors:

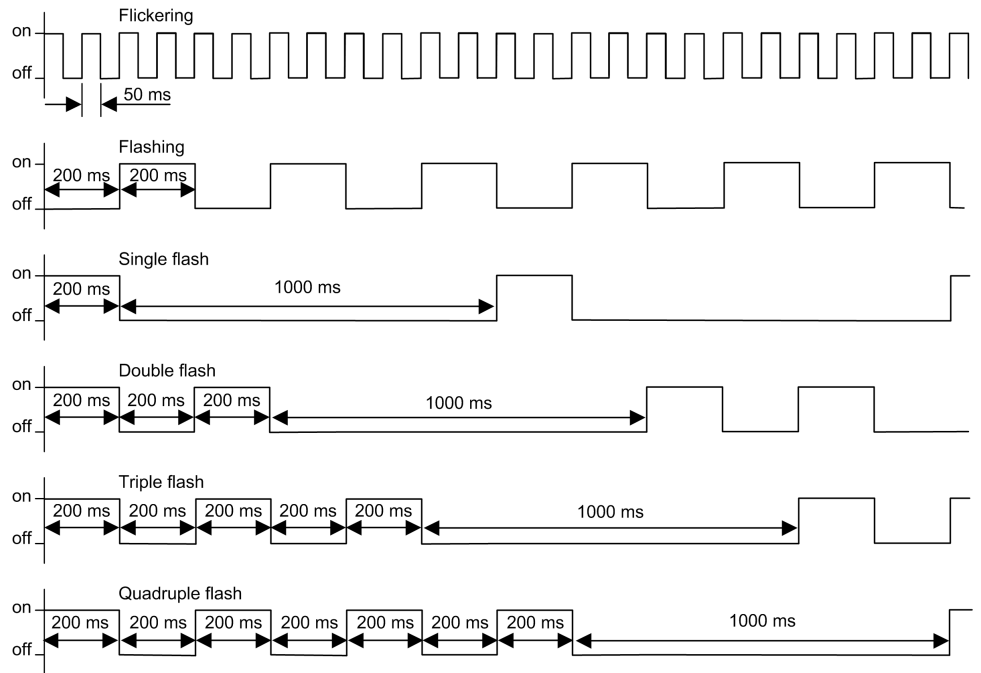

NOTE: With the exception of the **PWR** LED, each LED is ON for a few seconds, then OFF during the boot sequence. The LED behavior rules apply when the boot is completed successfully.

TM3 CANopen Bus Coupler Characteristics

Introduction

This section provides a general description of the characteristics of the TM3 CANopen bus coupler.

▲ WARNING
UNINTENDED EQUIPMENT OPERATION
Do not exceed any of the rated values specified in the environmental and electrical characteristics tables.
Failure to follow these instructions can result in death, serious injury, or equipment damage.

Dimensions

The following graphic shows the external dimensions for the TM3 CANopen bus coupler:

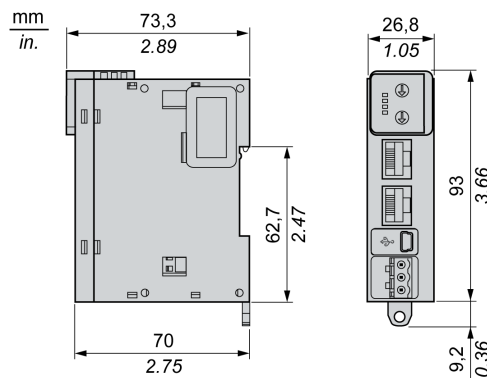

General Characteristics

The following table shows the characteristics of TM3 CANopen bus coupler:

Characteristics	Value
Connector insertion/removal durability	Over 100 times
Supplied power available for connected inputs and outputs modules	600 mA maximum
Current draw on 5 Vdc and 24 Vdc internal bus	

Rotary Switch

Overview

The two rotary switches located on the front panel of the TM3 CANopen bus coupler are used to set the CANopen bit rate and CANopen NodeID.

Default values on the rotary switches are:

- 0 for **TENS**
- 0 for **ONES**

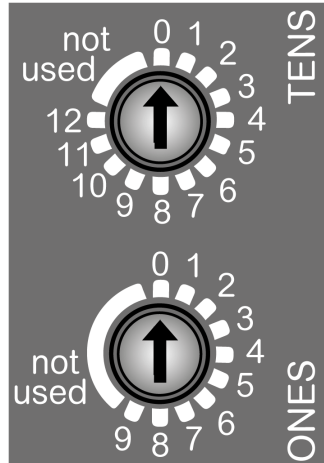

(TENS) Set the bit rate/represents the tens numbered 0 to 120.

(ONES) Authorize to set the bit rate when set to **not used** position/represents the numbers 0 to 9.

Setting the Bit Rate

The TM3 CANopen bus coupler detects a new bit rate selection by the rotary switches only during power up. The bit rate is written to non-volatile memory.

Set the **ONES** rotary switch to any of the unnumbered positions (**not used**) to set a particular bit rate with the **TENS** rotary switch.

NOTE: Any modification of the rotary switch position during operational mode is not taken into account. The **ERR** LED flashes red. See *status LEDs*, page 68 table.

Bit rate can also be set and verified via the web server. For more information, refer to the Modicon TM3 Bus Coupler Programming Guide.

To set the bit rate, follow the steps below:

Step	Action	Comment
1	Remove power to the bus coupler.	The bus coupler detects the changes only at the next power up cycle.
2	With a 2 mm or 2.5 mm slotted (flathead) screwdriver, set the ONES rotary switch to any of the unnumbered positions (not used). NOTE: Rotary switch is designed to be torqued normally by hand. Axial force must be inferior to 2 N.	Setting the rotary switch to any of these unnumbered positions prepares the bus coupler to accept a new bit rate.
3	With a 2 mm or 2.5 mm slotted (flathead) screwdriver, set the TENS rotary switch to the position that corresponds to your selected bit rate.	Use the bit rate selection table below to determine the position of the rotary switch.
4	Apply power to the bus coupler.	The bus coupler reads the rotary switch settings only during power up.
5	Wait for the RUN and the ERR LEDs to flash 3 times, then remain solid.	The bus coupler has written the new bit rate setting to memory.
6	Remove power to the bus coupler and set the CANopen address using the rotary switches, as described below in Setting the CANopen address, page 73.	The bit rate has been established for the bus coupler. It must be followed by the address setting to operate.

Bit-rate Selection Table

The following table shows the rotary switch positions and the bit rate:

Position TENS rotary switch	Bit rate
0	Not used
1	20 kbits/s
2	50 kbits/s
3	125 kbits/s
4	250 kbits/s
5	500 kbits/s
6	800 kbits/s
7	1 Mbits/s
8	Automatic bit-rate detection
9	250 kbits/s (default value)
10...12	Not used

NOTE: Setting the TENS rotary switch between 10 and 12 and unnumbered part will generate an error detected at the next power on.

CANopen Bit Rate Setting Example

The following figure shows an example when the bit rate is configured to 500 kbits/s:

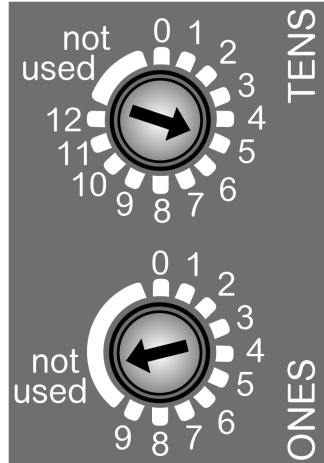

(TENS) Set to 5 to configure the bit rate to 500 kbits/s.

(ONES) Set to the **not used** position to authorize the bit rate setting.

Setting the CANopen Address

The TM3 CANopen bus coupler address (from 1 to 127, decimal) is configured using the two CANopen address settings rotary switches.

⚠ WARNING

UNINTENDED EQUIPMENT OPERATION

Do not use an address outside of the specified range (from 1 to 127).

Failure to follow these instructions can result in death, serious injury, or equipment damage.

To reset the CANopen bus coupler, remove power and provide a correct address before reapplying power to the bus coupler.

Set the CANopen address using the TENS rotary switch to represent the hundreds and tens digit and the ONES rotary switch to represent the units digit.

Carefully manage the addresses because each device on the network requires a unique address. Having multiple devices with the same address can cause unintended operation of your network and associated equipment.

⚠ WARNING

UNINTENDED EQUIPMENT OPERATION

- Do not connect the CANopen cable and apply power to the TM3 CANopen Bus Coupler on network that is operational (other devices connected in an ongoing control scheme) unless you first set the appropriate, unique address for the Bus Coupler.
- Assure that unique CANopen addresses are assigned to the TM3 CANopen Bus Coupler, and that those addresses are also unique from all other devices connected to the network.

Failure to follow these instructions can result in death, serious injury, or equipment damage.

CANopen Address Setting Example

The following figure shows an example when the CANopen address is set to 115:

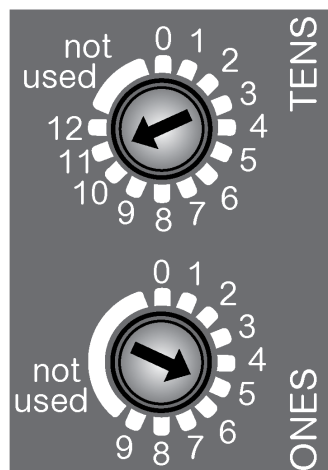

(TENS) Represents the tens, numbered 0 to 120, set to 110.

(ONES) Represents the numbers 0 to 9, set to 5.

CANopen Port

Overview

The TM3 CANopen bus coupler is equipped with two isolated RJ45 ports (**CN1**, **CN2**) enabling easy daisy-chain configuration, as shown in following graphic:

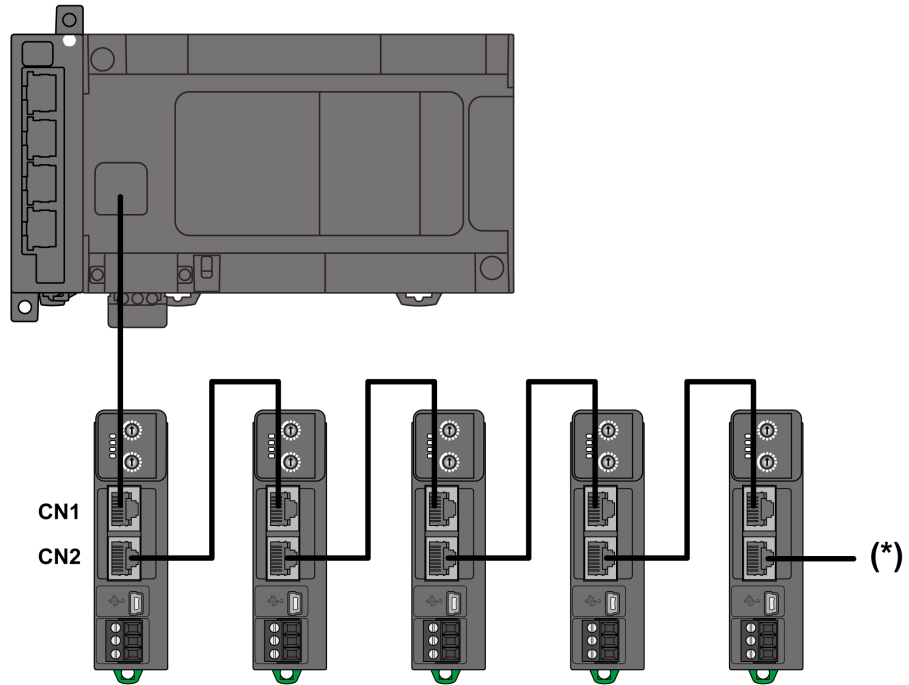

* You can connect a maximum of 64 CANopen devices, master inclusive, without use of a repeater. Both ends of the CAN bus must be terminated by terminating resistor.

Characteristics

This table describes the CANopen characteristics:

Characteristic	Description
Function	CANopen
Connector type	RJ45
Cable type	Shielded
Topology	Bus type

Pin Assignment

This graphic shows the RJ45 CANopen connector pin assignment:

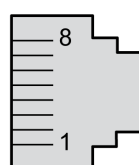

This table describes the RJ45 CANopen connector pins:

Pin N°	Signal	Description
1	CAN_H	CAN_H bus line (High)
2	CAN_L	CAN_L bus line (Low)
3	CAN_GND	CAN 0 Vdc
4	N.C.	No Connection
5	N.C.	No Connection
6	N.C.	No Connection
7	N.C.	No Connection
8	N.C.	No Connection

For more detailed information, refer to the CANopen Hardware Setup Manual.

Connecting the TM3 CANopen Bus Coupler to a PC

Overview

You can connect the TM3 CANopen bus coupler to a PC through the USB port.

USB Mini-B Port Connection

The USB Mini-B port is dedicated for firmware update, configuration download and web server access.

Cable Reference	Details
BMXXCAUSBH018	Grounded and shielded, this USB cable is suitable for long duration connections.
TCSXCNAMUM3P	This USB cable is suitable for short duration connections such as quick updates or retrieving data values.

NOTE: You can only connect one TM3 bus coupler or any other device associated with EcoStruxure Machine Expert and its component to the PC at any one time.

Using a typical USB cable, this connection is suitable for short duration connections to perform maintenance and inspect data values. It is not suitable for long-term connections such as commissioning or monitoring without the use of specially adapted cables to help minimize electromagnetic interference.

⚠ WARNING

UNINTENDED EQUIPMENT OPERATION OR INOPERABLE EQUIPMENT

- You must use a shielded USB cable such as a BMX XCAUSBH0•• secured to the functional ground (FE) of the system for any long-term connection.
- Do not connect more than one controller or bus coupler at a time using USB connections.
- Do not use the USB port(s), if so equipped, unless the location is known to be non-hazardous.

Failure to follow these instructions can result in death, serious injury, or equipment damage.

The communication cable should be connected to the PC first to minimize the possibility of electrostatic discharge affecting the TM3 CANopen bus coupler.

The following illustration shows the USB connection to a PC:

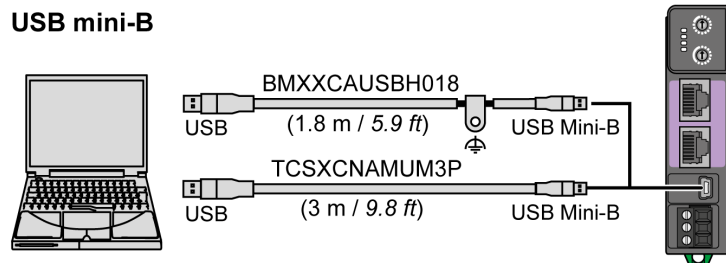

To connect the USB cable to your TM3 CANopen bus coupler, follow the steps below:

Step	Action
1	1a. If making a long-term connection using the cable BMXXCAUSBH018, or other cable with a ground shield connection, be sure to securely connect the shield connector to the functional ground (FE) or protective ground (PE) of your system before connecting the cable to your controller and your PC. 1b. If making a short-term connection using the cable TCSXCNAMUM3P or other non-grounded USB cable, proceed to step 2.
2	Connect your USB cable to the PC.
3	Connect the Mini connector of your USB cable to the TM3 CANopen bus coupler USB connector.

Glossary

A

application:

A program including configuration data, symbols, and documentation.

E

EIA rack:

(electronic industries alliance rack) A standardized (EIA 310-D, IEC 60297, and DIN 41494 SC48D) system for mounting various electronic modules in a stack or rack that is 19 inches (482.6 mm) wide.

EN:

EN identifies one of many European standards maintained by CEN (*European Committee for Standardization*), CENELEC (*European Committee for Electrotechnical Standardization*), or ETSI (*European Telecommunications Standards Institute*).

expansion bus:

An electronic communication bus between expansion I/O modules and a controller or bus coupler.

expansion connector:

A connector to attach expansion I/O modules.

F

FE:

(functional Earth) A common grounding connection to enhance or otherwise allow normal operation of electrically sensitive equipment (also referred to as functional ground in North America).

In contrast to a protective Earth (protective ground), a functional earth connection serves a purpose other than shock protection, and may normally carry current. Examples of devices that use functional earth connections include surge suppressors and electromagnetic interference filters, certain antennas, and measurement instruments.

H

HE10:

Rectangular connector for electrical signals with frequencies below 3 MHz, complying with IEC 60807-2.

HSC:

(high-speed counter) A function that counts pulses on the controller or on expansion module inputs.

I

I/O:

(input/output)

IEC:

(international electrotechnical commission) A non-profit and non-governmental international standards organization that prepares and publishes international standards for electrical, electronic, and related technologies.

IP 20:

(ingress protection) The protection classification according to IEC 60529 offered by an enclosure, shown by the letter IP and 2 digits. The first digit indicates 2 factors: helping protect persons and for equipment. The second digit indicates helping protect against water. IP 20 devices help protect against electric contact of objects larger than 12.5 mm, but not against water.

N**NEMA:**

(national electrical manufacturers association) The standard for the performance of various classes of electrical enclosures. The NEMA standards cover corrosion resistance, ability to help protect from rain, submersion, and so on. For IEC member countries, the IEC 60529 standard classifies the ingress protection rating for enclosures.

P**PE:**

(Protective Earth) A common grounding connection to help avoid the hazard of electric shock by keeping any exposed conductive surface of a device at earth potential. To avoid possible voltage drop, no current is allowed to flow in this conductor (also referred to as *protective ground* in North America or as an equipment grounding conductor in the US national electrical code).

program:

The component of an application that consists of compiled source code capable of being installed in the memory of a logic controller.

R**RJ45:**

A standard type of 8-pin connector for network cables defined for Ethernet.

T**terminal block:**

(terminal block) The component that mounts in an electronic module and provides electrical connections between the controller and the field devices.

Index

A

accessories	26
analog I/O modules	15
assembling to a TM3 bus coupler	36

B

bus coupler	
specifications	12

C

certifications and standards	30
characteristics	
TM3 CANopen Bus Coupler	70
TM3 Ethernet Bus Coupler	48
TM3 Modbus Serial Line Bus Coupler	58
communication ports	
CANopen port	75
Ethernet port	52
serial line port	63
controllers	
disassembling a module	37

D

DIN rail	35
----------------	----

E

electromagnetic susceptibility	30
environmental characteristics	28

G

grounding	44
-----------------	----

I

I/O configuration general information	17
inductive load	41
intended use	6

M

maximum hardware configuration	13
minimum clearances	32
mounting position	32

O

output protection	41
-------------------------	----

P

power supply	42
presentation	
TM3 CANopen Bus Coupler	67
TM3 Ethernet Bus Coupler	46
TM3 Modbus Serial Line Bus Coupler	56

Q

qualification of personnel	5
----------------------------------	---

R

rotary switch	
CANopen	71
Ethernet	49
serial line	59

T

TM3 CANopen Bus Coupler	
characteristics	70
presentation	67
TM3 Ethernet Bus Coupler	
characteristics	48
presentation	46
TM3 Modbus Serial Line Bus Coupler	
characteristics	58
presentation	56

W

wiring rules	39
--------------------	----

Schneider Electric
35 rue Joseph Monier
92500 Rueil Malmaison
France

+ 33 (0) 1 41 29 70 00

www.se.com

As standards, specifications, and design change from time to time,
please ask for confirmation of the information given in this publication.

© 2024 Schneider Electric. All rights reserved.

EIO0000003635.06